



TECHNICAL SPECIFICATIONS



Whole-House Duct Mount HEPA Air Cleaner

- **STANDARD 5 YEAR PARTS LIMITED WARRANTY**
- **When installed and registered with a complete Maytag system, this product carries a 12 Year All Parts Warranty.**
- **Product registration (by consumer or dealer) required for 12-year Warranty within a limited period of time after the installation. See current warranty document for details. This can be viewed at www.maytagvac.com or ask your sales representative.**



The Maytag Whole Home Duct Mount HEPA Air Cleaner offers the homeowner the ultimate in IAQ comfort. This 3-stage filtration system is unmatched by any competitor. The first stage is a high efficient MERV 11 prefilter, which removes lint and larger particles before they enter the HEPA filter. Stage two is an activated carbon prefilter, which removes odors to extend the life of the HEPA filter. The third stage is the long-life, 99.97% HEPA media filter which removes particles down to 0.3 micron and becomes more efficient as the filter loads with dirt over time. The Duct Mount HEPA system delivers 320 CFM of pure air, without adding static pressure to the HVAC System. The unit can be duct mounted, collar mounted or used freestanding. The Maytag Whole Home Duct Mount HEPA carries a system warranty if sold with a matched Maytag system.

Standard Features

- 3 Stage filtration system.
- 99.97% efficient down to 0.3 micron and larger on the first pass of air and it becomes more efficient with continuous use.
- Duct or collar mounted, or free-standing installation.
- Delivers 320 CFM of pure air.
- One piece wrap, powder coated steel cabinet for rigid installation and durability.
- Plug-in power cord.

DIMENSIONS

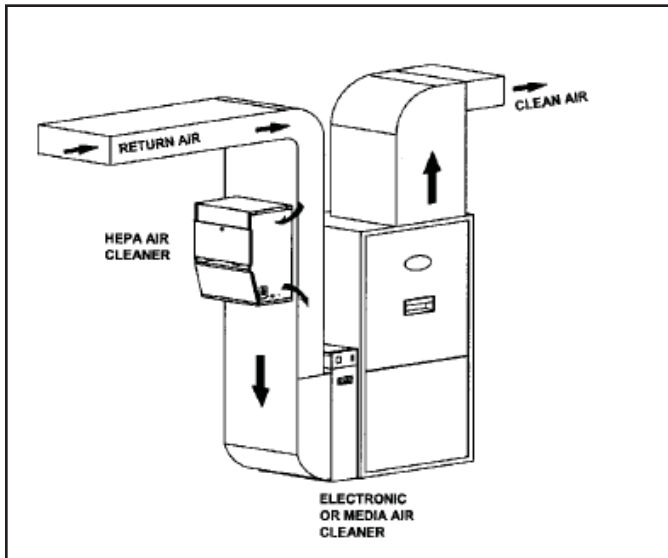

Figure 1. Duct Mount Installation

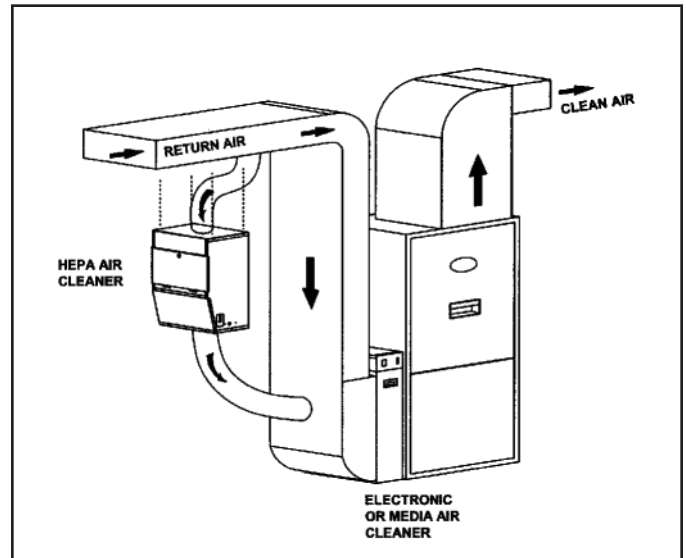

Figure 2. Collar Mount Installation

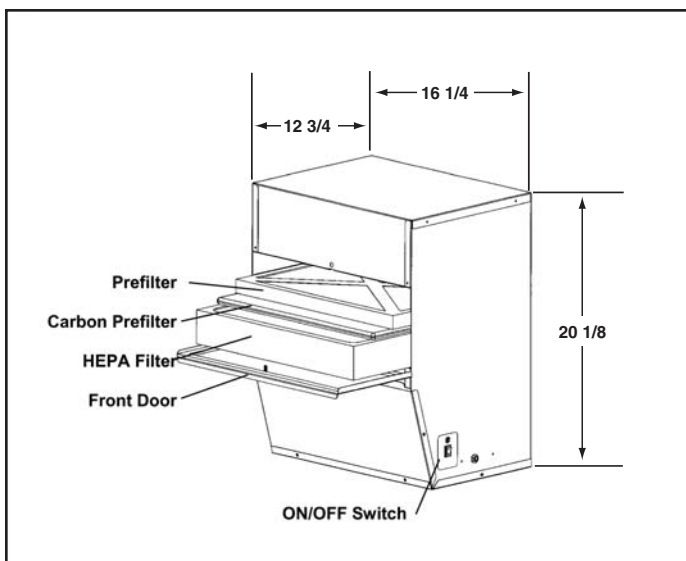

Figure 3. Whole Home Duct Mount HEPA

ACCESSORIES

Replacement Media	Part Number
True HEPA filter	919011
Prefilter: Merv 11	919012
Carbon Prefilter	919013

SPECIFICATIONS

Model	N-HEPA DM400	
Air Flow	320 CFM	544 m ³ /hr
Whole House Air Changes Per Day 1500 sq ft home 2000 sq ft home	39 Air Changes/Day 29 Air Changes/Day	
Prefilter: Removes lint and large particles	Replace every 3-6 months	
Carbon Prefilter: Removes odors	Replace every 3-6 months	
True HEPA Media Filter: 99.97% efficient on 0.3 micron	40 ft ² Replace every 2-3 years	3.7 m ² Replace every 2-3 years
Cabinet Dimensions	Height Width Depth	51.1 cm 41.3 cm 32.4 cm
Intake Duct Fitting	14.5 x 3.75 in or 8 in (dia)	36.8 x 9.5 cm or 20.3 cm (dia)
Outflow Duct Fitting	14.5 x 4.37 in or 8 in (dia)	36.8 x 11.1 cm or 20.3 cm (dia)
Input Voltage	120 V 60 Hz	
Power Consumption	125 Watts	
Power Cord	10.0 ft	3.05 m
Cabinet	22 gauge	
Unit Weight	38 lbs	17.2 kg
Part Number 918772	918772	



Before purchasing this appliance, read important energy cost and efficiency information available from your retailer. Specifications and illustrations subject to change without notice and without incurring obligations.

Manufactured under license by NORDYNE, O'Fallon, MO. ®Registered Trademark/™ Trademark of Maytag Corporation or its related companies. ©2007. All rights reserved.

036C-0607 (Replaces 036C-0307)

Printed in U.S.A. (06/07)