TECHNICAL SPECIFICATIONS

P3RD Series

Single Packaged Air Conditioner, Single Phase

P3RD-13 SEER

2 thru 5 Ton Units

Cooling: 24,000 to 60,000 Btuh

The P3 Series single packaged air conditioners are high efficiency self contained cooling and heating units that can be installed on a slab. Units are ETL and ETLc listed.

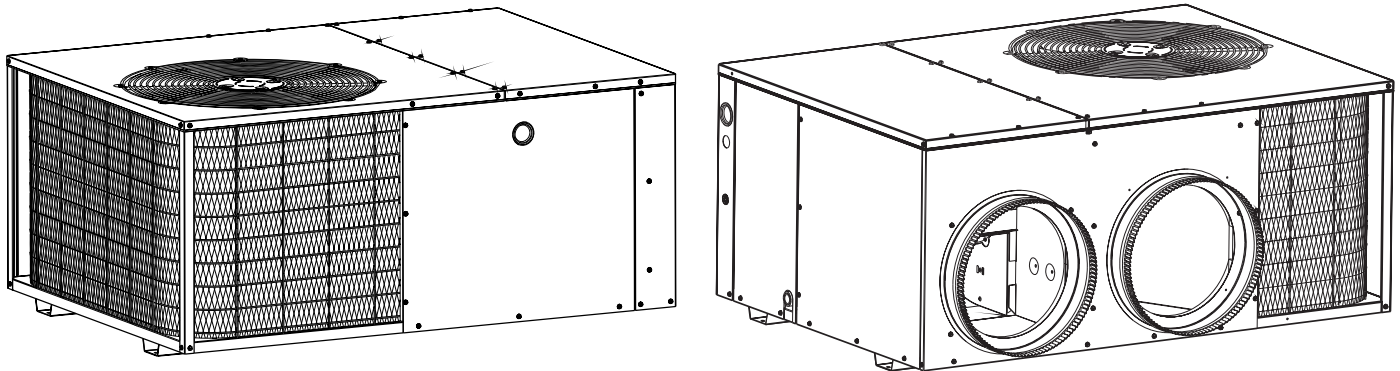

FEATURES AND BENEFITS

- **State-of-the-art compressor** is standard equipment.
- **Designed using galvanized steel** with a polyester urethane coat finish. The 950 hour salt spray finish resists corrosion 50% better than comparable units.
- **Both indoor and outdoor coils** are designed to optimize heat transfer, minimize size and cost, and increase durability and reliability.
- **The service valves are easily accessible** and simplify servicing of the refrigeration system.
- **A wire coil guard and mesh hail guard that will never rust** protects the coil from being damaged by balls, lawnmowers, hail, etc.
- **Designed to make servicing easier** for the contractor, access panels are provided to all major components.
- **0" clearance** to combustibles on duct side of the unit allows for installations in tight areas.
- **Easy access** to evaporator for cleaning and general maintenance.
- **Drain trap** design optimizes drainage capabilities.
- **Easy to install** electric heat strip provides up to 20 kw of heat output.
- **Compact footprint and profile** make the P3 Series easy to install and transport.
- **1 year limited parts warranty**
- **1 year limited labor warranty**
- **10 year limited compressor warranty**

MODEL IDENTIFICATION CODE

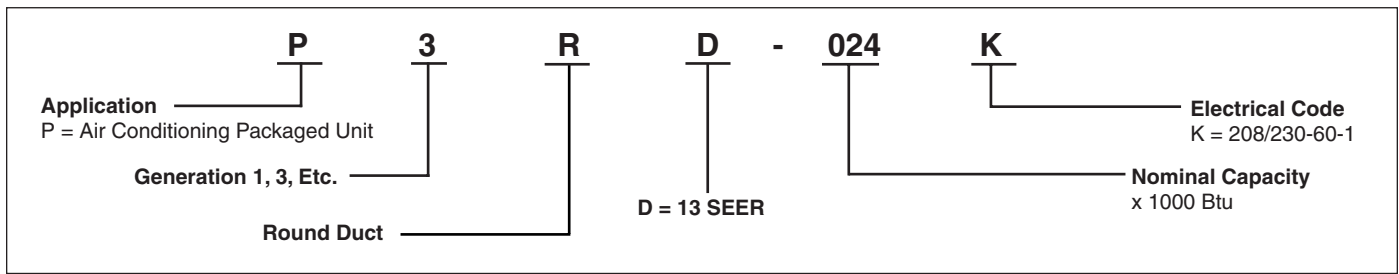

DIMENSIONS

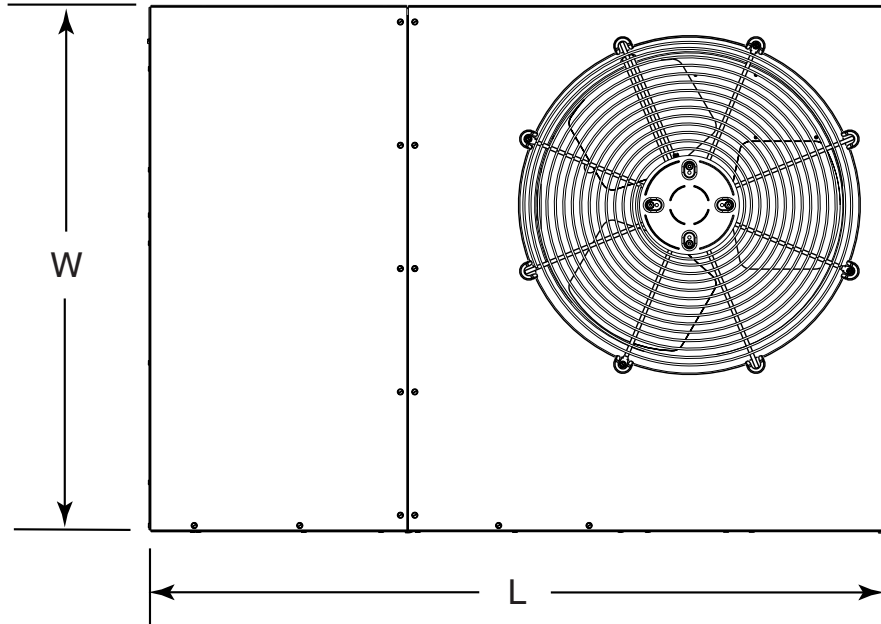

Top View

Model No. P3RD-	(L) Length	(W) Width	(H) Height	A	B
024K	49	35	30.2	35.02	2.48
030K	49	35	30.2	35.02	2.48
036K	49	35	30.2	35.02	2.48
042K	49	35	30.2	35.02	2.48
048K	49	35	30.2	35.02	2.48
060K	49	35	34.2	35.02	2.48

Model No. P3RD-	Return Diameter (in)	Supply Diameter (in)
024K	14	12
030K	14	12
036K	14	12
042K	14	12
048K	14	12
060K	14	12

DIMENSIONS Continued

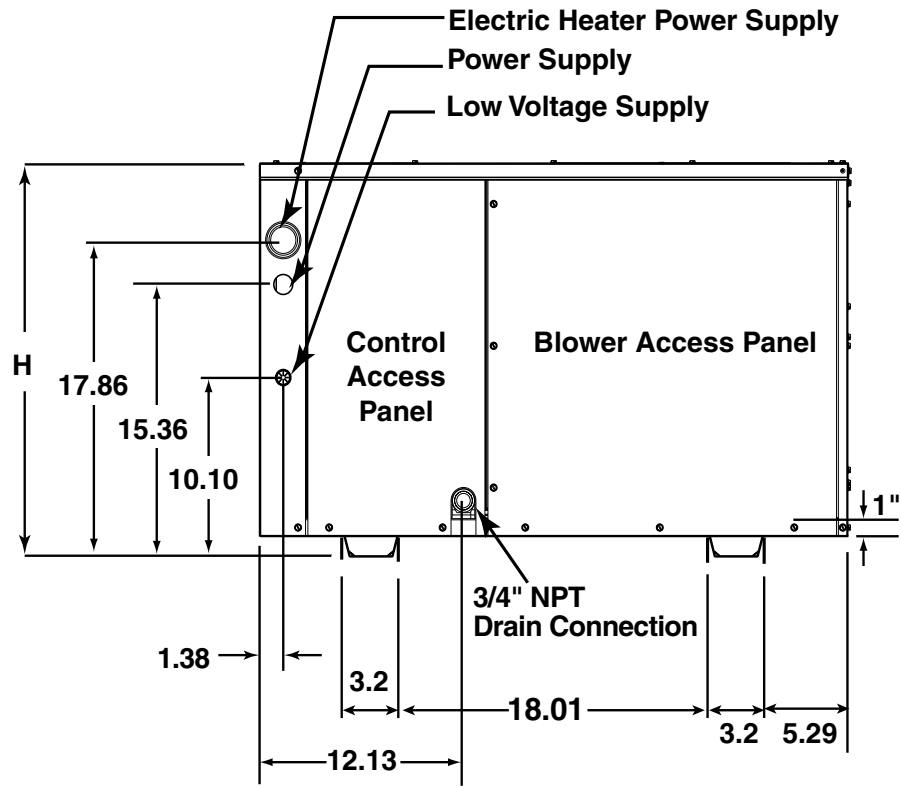

Side View

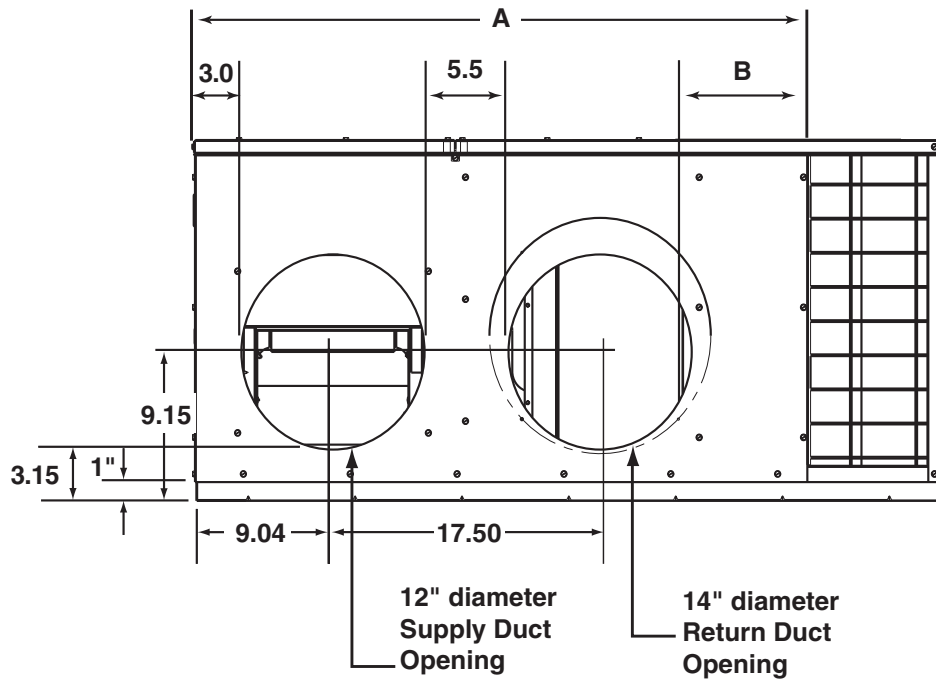

Back (Duct) View

PHYSICAL SPECIFICATIONS

P3RD Models

Model No. P3RD	024K	030K	036K	042K	048K	060K
Electric Rating - 60Hz (a)						
Operating Voltage Range	187 - 253	187 - 253	187 - 253	187 - 253	187 - 253	187 - 253
Min. Circuit Ampacity (a)	16.7	21.9	22.2	32.2	35.3	42.5
Field Wire Size - AWG (a)	12	10	10	8	8	8
Delay Fuse - Max. (b)	25	35	35	50	50	70
Total Unit - Amps	13.8	17.9	18.2	26.8	29.7	35.4
Compressor Data						
Volts	208 - 230	208 - 230	208 - 230	208 - 230	208 - 230	208 - 230
Rated Load Amps	11.6	15.7	15.7	21.5	22.5	28.2
Lock Rotor Amps	54.0	68.0	68.0	104.0	137.0	141.0
Fan Motor and Condenser						
Fan Motor - HP - RPM	1/8 - 1100	1/8 - 1100	1/8 - 1100	1/8 - 1100	1/4 - 1100	1/4 - 1100
Fan Motor - Amps	.84	.84	.84	1.2	1.2	1.2
Fan Diameter / CFM	20" - 2800	20" - 2800	20" - 2800	20" - 3000	20" - 3000	20" - 3000
Motor and Evaporator						
Blower Motor - HP - RPM	1/4 - 980	1/4 - 980	1/4 - 980	1/2 - 1000	3/4 - 1060	3/4 - 1060
Blower Motor - Amps	1.4	1.4	1.4	4.1	6	6
CFM @ E.S.P. - in. W.C.	770 @ .30	1020 @ .30	1000 @ .30	1300 @ .30	1500 @ .30	1500 @ .30
Refrigerant Charge - Oz.	136	123	136	128	146	147
Shipping weight - lbs.	290	295	295	312	318	348

(a) Amperage and wire size based on refrigeration system only. See Electrical Data tables for supplemental electric heaters. Refer to National Electric Code for additional derating factors for field installed conductors.

(b) Use time delay fuse or "HACR" type circuit breaker.

ELECTRICAL DATA

Model Number	Heater Installed Nom. KW	Single Supply Circuit Option										Multiple Supply Circuit Option									
		Minimum Circuit Amp.					Maximum Over-current Rating*					Circuit A					Circuit B				
		Rec Wire Gauge (60°C Cu)	Rec Wire Gauge (75°C Cu)	Rec Wire Gauge (90°C Cu)	Minimum Circuit Amp.	Maximum Over-current Rating*	Rec Wire Gauge (60°C Cu)	Rec Wire Gauge (75°C Cu)	Rec Wire Gauge (90°C Cu)	Minimum Circuit Amp.	Maximum Over-current Rating	Rec Wire Gauge (60°C Cu)	Rec Wire Gauge (75°C Cu)	Rec Wire Gauge (90°C Cu)	Minimum Circuit Amp.	Maximum Over-current Rating	Rec Wire Gauge (60°C Cu)	Rec Wire Gauge (75°C Cu)	Rec Wire Gauge (90°C Cu)	Minimum Circuit Amp.	Maximum Over-current Rating
P3RD-024K	0	12	12	12	16.7	25	6	8	8	50	60	6	8	8	26.8	60	6	8	8	26.8	60
	5	10	10	10	26.8	30	8	8	8	50	60	8	8	8	26.8	60	8	8	8	26.8	60
	8	8	8	8	41.3	45	8	8	8	50	60	8	8	8	26.8	60	8	8	8	26.8	60
	10	6	6	6	51.8	60	6	6	6	50	60	6	6	6	26.8	60	6	6	6	26.8	60
P3RD-030K	0	10	10	10	21.9	35	10	10	10	50	60	10	10	10	26.8	60	10	10	10	26.8	60
	5	10	10	10	26.8	35	10	10	10	50	60	10	10	10	26.8	60	10	10	10	26.8	60
	8	8	8	8	41.3	45	8	8	8	50	60	8	8	8	26.8	60	8	8	8	26.8	60
	10	6	6	6	51.8	60	6	6	6	50	60	6	6	6	26.8	60	6	6	6	26.8	60
	15	3	4	4	76.8	80	3	4	4	50	60	3	4	4	26.8	60	3	4	4	26.8	60
P3RD-036K	0	10	10	10	22.2	35	10	10	10	50	60	10	10	10	26.8	60	10	10	10	26.8	60
	5	10	10	10	26.8	35	10	10	10	50	60	10	10	10	26.8	60	10	10	10	26.8	60
	8	8	8	8	41.3	45	8	8	8	50	60	8	8	8	26.8	60	8	8	8	26.8	60
	10	6	6	6	51.8	60	6	6	6	50	60	6	6	6	26.8	60	6	6	6	26.8	60
	15	3	4	4	76.8	80	3	4	4	50	60	3	4	4	26.8	60	3	4	4	26.8	60
	20	1	2	3	105.1	110	1	2	3	50	60	1	2	3	26.8	60	1	2	3	26.8	60
P3RD-042K	0	8	8	8	32.2	50	8	8	8	50	60	8	8	8	26.8	60	8	8	8	26.8	60
	5	8	8	8	32.2	50	8	8	8	50	60	8	8	8	26.8	60	8	8	8	26.8	60
	8	6	6	6	44.7	50	6	6	6	50	60	6	6	6	26.8	60	6	6	6	26.8	60
	10	4	4	4	55.1	60	4	4	4	50	60	4	4	4	26.8	60	4	4	4	26.8	60
	15	3	4	4	80.1	90	3	4	4	50	60	3	4	4	26.8	60	3	4	4	26.8	60
	20	1	2	3	105.1	110	1	2	3	50	60	1	2	3	26.8	60	1	2	3	26.8	60
P3RD-048K	0	8	8	8	35.3	50	8	8	8	50	60	8	8	8	26.8	60	8	8	8	26.8	60
	5	8	8	8	35.3	50	8	8	8	50	60	8	8	8	26.8	60	8	8	8	26.8	60
	8	6	6	6	47.1	50	6	6	6	50	60	6	6	6	26.8	60	6	6	6	26.8	60
	10	4	4	4	57.5	60	4	4	4	50	60	4	4	4	26.8	60	4	4	4	26.8	60
	15	3	4	4	82.5	90	3	4	4	50	60	3	4	4	26.8	60	3	4	4	26.8	60
	20	1	2	3	107.5	110	1	2	3	50	60	1	2	3	26.8	60	1	2	3	26.8	60
P3RD-060K	0	6	8	8	42.45	70	6	8	8	50	60	6	8	8	26.8	60	6	8	8	26.8	60
	5	6	8	8	42.45	70	6	8	8	50	60	6	8	8	26.8	60	6	8	8	26.8	60
	8	6	8	8	47.08	70	6	8	8	50	60	6	8	8	26.8	60	6	8	8	26.8	60
	10	4	6	6	57.5	70	4	6	6	50	60	4	6	6	26.8	60	4	6	6	26.8	60
	15	3	4	4	82.5	90	3	4	4	50	60	3	4	4	26.8	60	3	4	4	26.8	60
	20	1	2	3	107.5	110	1	2	3	50	60	1	2	3	26.8	60	1	2	3	26.8	60

*When overcurrent rating exceeds 60, internal circuit breakers must be installed in addition to branch circuit protection at distribution panel.

SYSTEM HEATING AND COOLING CAPACITIES

Model Number P3RD-	Cooling Btuh	SEER	EER
024K	24,000	13	12.4
030K	30,000	13	12.1
036K	35,400	13	11.8
042K	40,500	13	11.5
048K	47,500	13	11.3
060K	55,500	13	11.0

BLOWER PERFORMANCE

Model Number P3RD-		External Static Pressure (in. WC)					
		0.1	0.2	0.3	0.4	0.5	0.6
024K †	High	1120	1060	1000	930	860	750
	Low	840	800	760	710	610	N/A
030K †	High	1450	1380	1320	1240	1150	1050
	Low	1070	1050	1030	980	930	N/A
036K †	High	1480	1440	1390	1330	1270	1190
	Low	1270	1230	1190	1140	1080	1000
042K	Tap T1	1100	900	750	650	580	520
	Tap T2	1170	1080	1000	620	900	860
	** Tap T3	1220	1180	1140	1100	1070	1020
	* Tap T4	1370	1333	1300	1260	1230	1180
	Tap T5	1410	1340	1450	1320	1280	1240
048K	Tap T1	1380	1360	1340	1300	1260	1240
	** Tap T2	1530	1480	1450	1420	1390	1350
	* Tap T3	1570	1540	1500	1475	1440	1405
	Tap T4	1740	1700	1650	1630	1600	1560
	Tap T5	2130	2080	1970	1890	1850	1800
060K	Tap T1	1380	1360	1340	1300	1260	1240
	** Tap T2	1530	1480	1450	1420	1390	1350
	* Tap T3	1570	1540	1500	1475	1440	1405
	Tap T4	1740	1700	1650	1630	1600	1560
	Tap T5	2130	2080	1970	1890	1850	1800

COPPER WIRE SIZE – AWG (1% Voltage Drop)				
Supply Wire Length-Feet				Supply Circuit Ampacity
200	150	100	50	
6	8	10	14	15
4	6	8	12	20
4	6	8	10	25
4	4	6	10	30
3	4	6	8	35
3	4	6	8	40
2	3	4	6	45
2	3	4	6	50

Wire Size based on N.E.C. for 60° type copper conductors.

* Factory set cooling speed

** Factory set electric heating speed

† Factory set cooling and electric heating speed

ACCESSORIES

Heater Application Matrix

Model Number P3RD-	H3HK-005H-01A 917166A	H3HK-008H-01A 917167A	H3HK-010H-01A 917168A	H3HK-015H-01A 917169A	H3HK-020H-01A 917170A	H3HK-015H-21A 917172A	H3HK-020H-21A 917173A
024K	X(0)	X(0)	X(0)	NA	NA	NA	NA
030K	X(0)	X(0)	X(0)	X(2)	NA	X(0)	NA
036K	X(0)	X(0)	X(0)	X(2)	NA	X(0)	NA
042K	X(0)	X(0)	X(0)	X(2)	X(2)	X(0)	X(1)
048K	X(0)	X(0)	X(0)	X(2)	X(2)	X(0)	X(1)
060K	X(0)	X(0)	X(0)	X(2)	X(2)	X(0)	X(1)

NA = Not Approved

() = Number of internal circuit breaker kits required.

Duct Kits

Description	Part Number
MHFK-12-SW (Single Wide Fitting Kit - 12")	911468A
MHFK-12-DW (Double Wide Fitting Kit - 12")	911469A
MHFK-14-SW (Single Wide Fitting Kit - 14")	914957
MHFK-14-DW (Double Wide Fitting Kit - 14")	914956
UFK-2RMI, 12"x12"x12"	
"Y" fitting with 2 clamps	911470
Clamps, 10-14" diameter	668659
MHFK-12/14-SW (Single Wide Fitting Kit-12/14)	919455
MHFK-12/14-DW (Double Wide Fitting Kit-12/14)	919456

Heater Kit Accessories

Description	Part Number
4-Pole single circuit adaptor	913350
6-Pole single circuit adaptor	913556
Circuit Breaker Single Phase (2-pole)	913554



CERTIFICATION APPLIES
ONLY WHEN THE
COMPLETE SYSTEM
IS LISTED WITH ARI

We Encourage
Professionalism



Through Technician
Certification by NATE

O'Fallon, MO

NORDYNE

156C-0607 (Replaces 156C-0706)

Before purchasing this appliance, read important energy cost and efficiency information available from your retailer. Specifications and illustrations subject to change without notice and without incurring obligations. Printed in U.S.A. (06/07)