

P4SD Series

Single Packaged Air Conditioning

13 SEER

3, 4 and 5 Ton Units

The P4 Series single packaged air conditioners are high efficiency self contained cooling units that can be installed on a roof or on a slab. The convertible unit design makes installations simple in all applications. Units are ETL and ETLc listed.

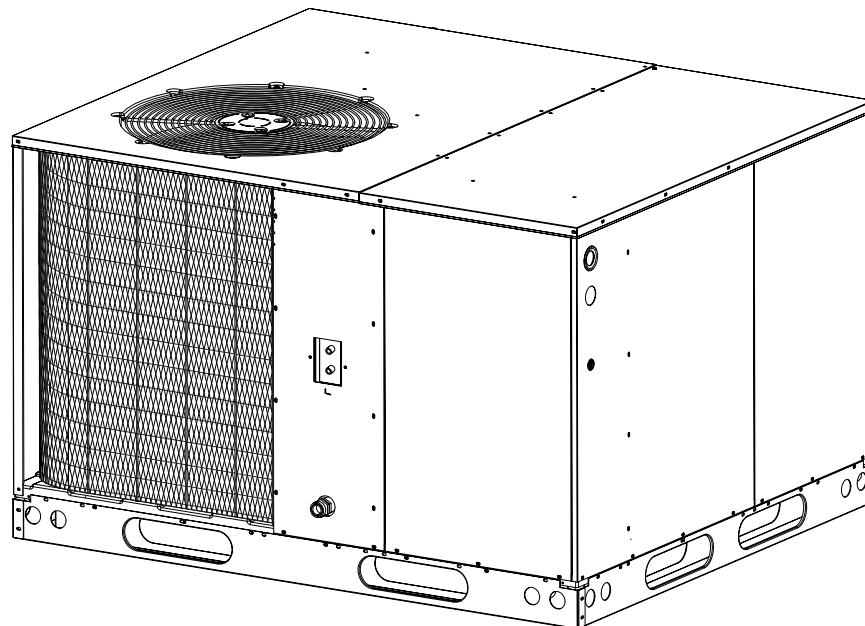

FEATURES AND BENEFITS

- **Compact Footprint/Low Profile**
Easy to handle and transport.
- **Heavy-Gauge, Full Perimeter Base Rails**
Facilitates forklift handling and curb mounting.
- **Convertible Air Delivery**
Horizontal or downflow to accommodate rooftop or horizontal application.
- **Galvanized Steel with Polyurethane Finish**
Provides a minimum of 950 hours salt spray protection.
- **Externally Accessible Service Ports**
Quick access to refrigerant system without disrupting operation.
- **Access to Controls and Major Components**
Easy in and out service.
- **Corrosion-Resistant Drain Pan**
Quickly drains away evaporator condensate.
- **Plastic Coated Coil Guard and Plastic Mesh Hail Guard** - Protects unit coil from damage.
- **Designed to Make Servicing Easier for the Contractor**
Access panels are provided to all major components and the compressor.
- **Easy to Install**
Electric heat strip provides up to 20 KW of heat output.
- **Proven, Industry Standard Components**
Easier service and availability.
- **Quiet Operation**
Low vibration. 20" fan blade combined with custom venturi condenser fan.
- **Accessories**
Roof curbs, economizers, fresh air dampers and more.
- **5 Year Limited Parts Warranty**
- **Two Year Limited Labor Warranty**

MODEL IDENTIFICATION CODE

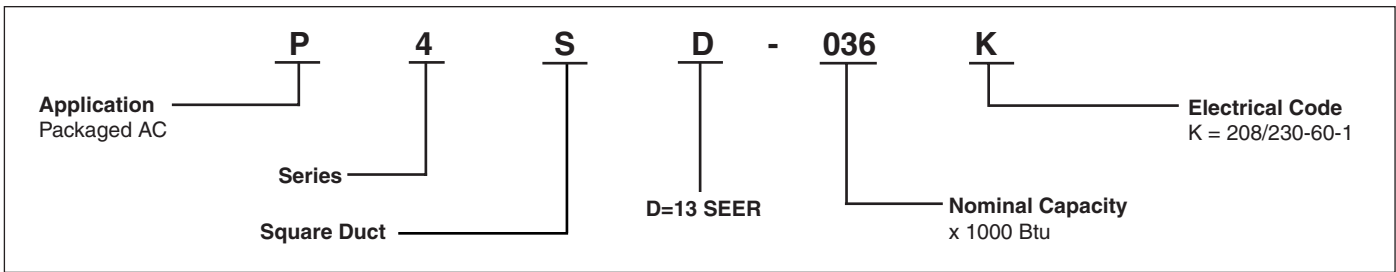

DIMENSIONS

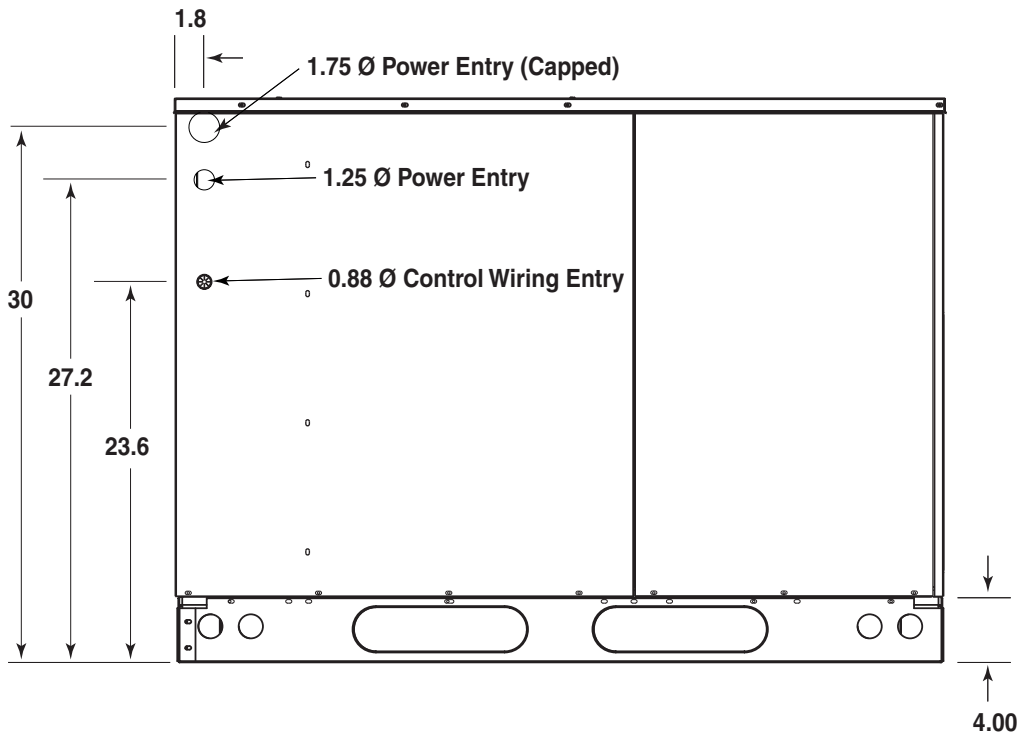

Model Number P4SD	Unit Weight	Center of Gravity		Height (in inches) C	
		A	B	with base rails	without base rails
036	405	29.5	26.0	37.7	35.3
048	415	29.5	26.5	37.7	35.3
060	480	30.0	27.5	41.7	39.3

DIMENSIONS (Continued)

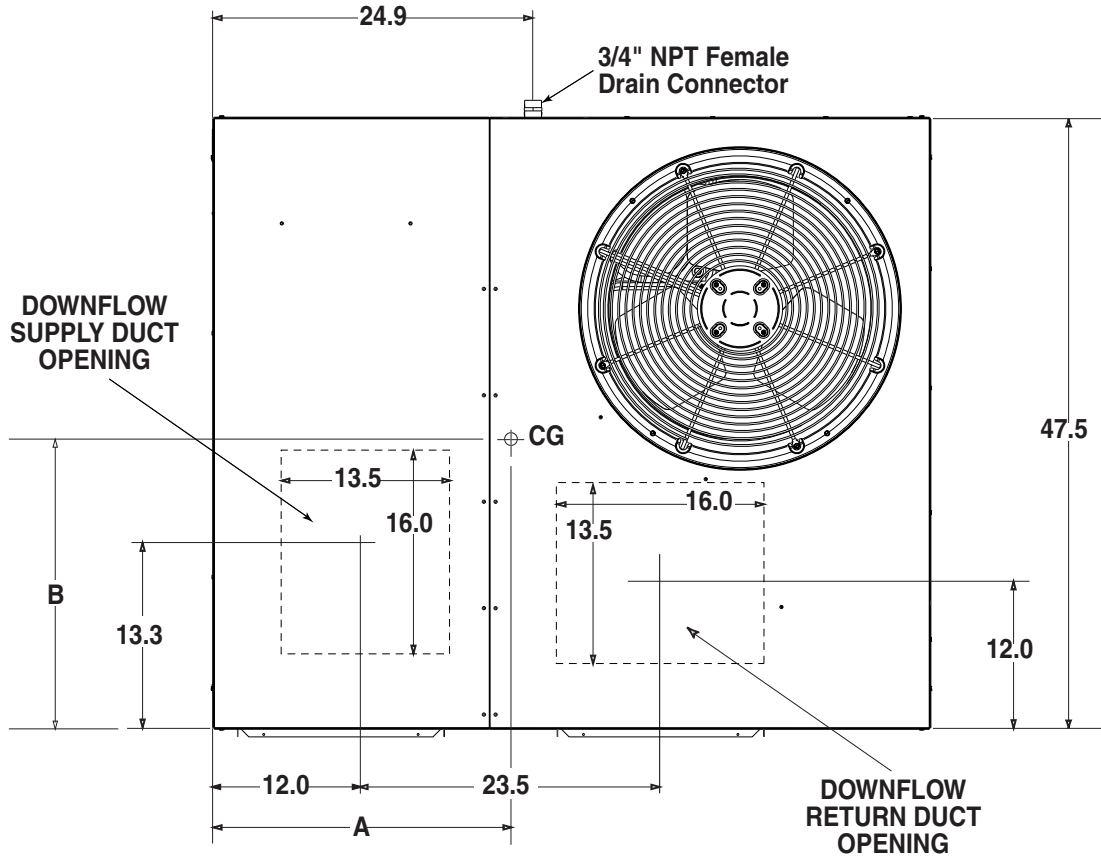

Top View

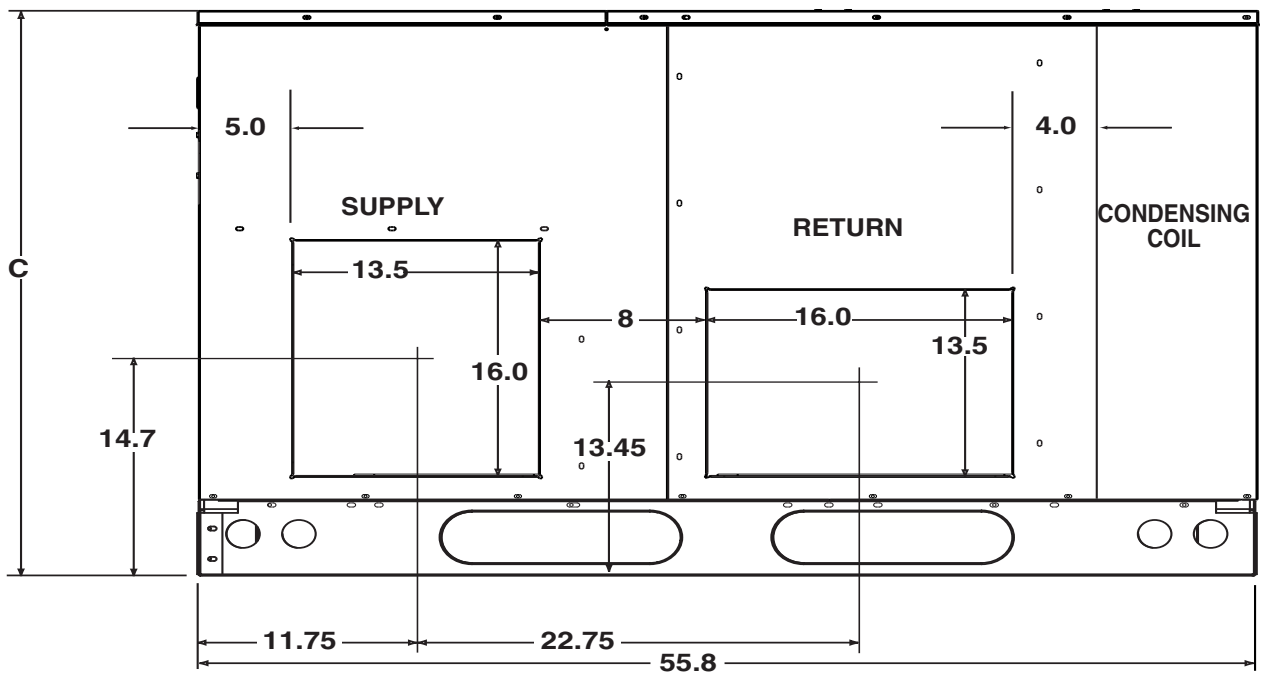

Back (Duct) View

SPECIFICATIONS

Model Number	P4SD		
	036K	048K	060K
Performance			
Capacity -Cooling BTUH	35,000	47,000	56,500
Efficiency - SEER	13.00	13.00	13.00
EER (Btuh/watt)	11.0	11.0	11.0
Electrical Rating - 60 Hz			
Phase	1	1	1
Operating Voltage Range	187 - 253	187 - 253	187 - 253
Compressor Data			
Volts	208 / 230	208 / 230	208 / 230
Rated Load Amps	16	24.3	28.2
Lock Rotor Amps	77	131	141
Indoor Blower			
Type / No. of Speeds	DD / 3	NA / 5	NA / 5
Motor - HP / RPM	1/4 - 1100	1/2 - 1685	3/4 - 2010
Motor - Amps	1.3	4.1	6.0
Outdoor Fan			
Motor - HP / RPM	1/8 - 1100	1/4 - 1100	1/4 - 1100
Motor - Amps	1.2	1.2	1.2
Fan Diameter / CFM	20/3600	20/3600	20/3600
Refrigerant Charge - Oz.	91.5	171.2	187.2
Shipping Weight	415	425	490

BLOWER PERFORMANCE

Model Number		External Static Pressure Drop - inches water column							
P4SD		0.1	0.2	0.3	0.4	0.5	0.6	0.7	0.8
036	High	1600	1510	1410	1310	1200	1070	930	760
	Medium*	1410	1330	1250	1150	1050	940	820	670
	Low	1130	1070	1000	930	850	760	650	530
048	Tap T1	1190	1100	1000	970	910	855	790	760
	Tap T2	1230	1180	1120	1080	1030	980	930	875
	Tap T3	1310	1259	1200	1152	1097	1044	991	931
	* Tap T4	1463	1416	1400	1321	1270	1220	1175	1120
	** Tap T5	1680	1640	1600	1550	1520	1470	1430	1380
060	Tap T1	1515	1450	1380	1350	580	1250	1200	1160
	Tap T2	1580	1520	1460	1400	1300	1300	1260	1230
	* Tap T3	1740	1690	1650	1600	1360	1500	1460	1390
	** Tap T4	1960	1910	1840	1820	1540	1740	1700	1600
	Tap T5	2090	2050	2010	1975	1780	1900	1850	1790

* Denotes factory set cooling speed

** Denotes factory set electric heating speed

HEATER APPLICATION MATRIX

Model Number	H3HK-005H-01A	H3HK-008H-01A	H3HK-010H-01A	H3HK-015H-01A	H3HK-020H-01A	H3HK-015H-21A	H3HK-020H-21A
	917166A	917167A	917168A	917169A	917170A	917172A	917173A
P4S()-036K	X	X	X(2)	X(2)	NA	X	NA
P4S()-048K	X(2)	X(2)	X(2)	X(3)	X(3)	X(1)	X(1)
P4S()-060K	X(2)	X(2)	X(2)	X(3)	X(3)	X(1)	X(1)

NA = Not Applicable.

() = Number of internal circuit breaker kits required.

MODEL IDENTIFICATION CODE

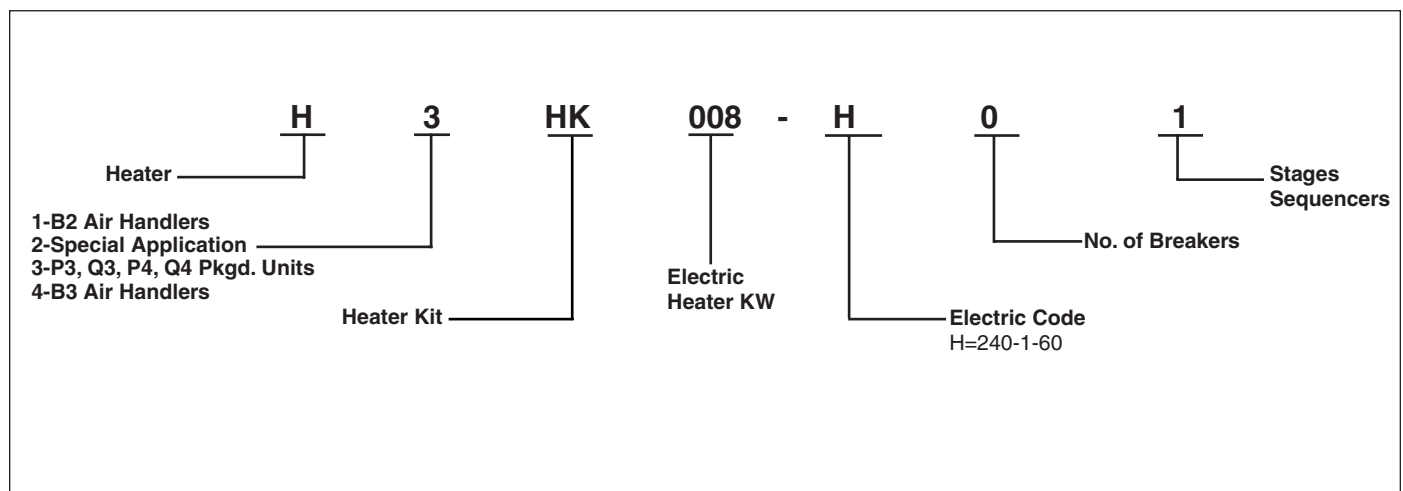

ACCESSORIES

Description	Part Number
Roof Curb (8")	547830
Roof Curb (14")	547831
Roof Curb (18")	547850
Roof Curb (24")	547851
Supply/return transition, 16"	547834
Supply/return transition, 18"	547835
Concentric diffuser, flush, 16"	547836
Concentric diffuser, flush, 18"	547837
Concentric diffuser, step down 16"	547838
Concentric diffuser, step down 18"	547839
Circuit Breaker, disconnect 3 phase	913740
Manual Fresh Air Damper	547832
Motorized Fresh Air Damper	547840
Economizer, downflow w/filter (does not require filter kit) modulating	547833
Economizer, horizontal modulating	547841
Economizer, horizontal 3-position w/filter	547896
Economizer, downflow 3-position w/filter	547897
Power Exhaust, downflow economizer (special order)	547842
Power Exhaust horizontal economizer (special order)	547843
HOOD TYPE HAIL GUARD 30" X 60" P4SA036, R4GA024, 030, 036, 042, R4GC024	547844
HOOD TYPE HAIL GUARD 30" X 76" P4SA048, P4SC036, Q4SA036	547845
HOOD TYPE HAIL GUARD 34" X 76" P4SA060, P4SC048, 060, Q4SA048, 060, Q4SC036, R4GA048, 060, R4GC030, 036, 042	547846
HOOD TYPE HAIL GUARD 38" X 76" Q4SC048, 060, R4GC048, 060	547847
CO2 sensors (special order)	547848
DUCT SMOKE DETECTOR PHOTO ELEC	547892
MULTI SIGNAL CONTROL	547893
SAMPLING TUBE ST3	547894
SAMPLING TUBE ST5	547895
Filter Rack, All Downflow Applications (not required with economizer)	547885
Filter Kit (not required with economizer) R4GA 024 -042, R4GC 024, P4SA 036	547886
Filter Kit (not required with economizer) P4SA 048, P4SC 036, Q5SA 036	547887
Filter Kit (not required with economizer) R4GA 048 - 060, R4GC 030 - 042, P4SA 060, P4SC 048 - 060, Q4SA 048 - 060, Q4SC 036	547888
Filter Kit (not required with economizer) R4GC 048 - 060, Q4SC 048 - 060	547889
Universal Hard Start Kit	912933
Low Pressure Switch Kit	913551
High Pressure Switch Kit	913550
Low Ambient Kit	913549A
P-Trap Kit	913810
U.S. LP Gas Conversion Kit (0 ft to 10,000 ft above sea level)	903616
Canadian LP Gas Conversion Kit (0 to 4,500 ft above sea level)	903617
Outdoor Thermostat Kit	913852



CERTIFICATION APPLIES
ONLY WHEN THE
COMPLETE SYSTEM
IS LISTED WITH ARI

**We Encourage
Professionalism**



**Through Technician
Certification by NATE**