

DS4BF Series R-410A Extra High Efficiency Air Conditioner 16 SEER Residential System 2 - 5 Ton Capacity

The DS4BF Series now offers the choice of an air conditioner that uses a more efficient and environmentally friendly refrigerant designated R-410A. The DS4BF Series of air conditioners offers exceptional performance. The unit, when combined with our engineered coils or air handlers, offers a line of quality, 16 SEER split system cooling equipment.

FEATURES and BENEFITS

- **R-410A Refrigerant** – Earth friendly non-ozone depleting refrigerant.
- **ComfortAlert™ Module** – Detects system and electrical problem conditions. A diagnostics key directs the service technician to the root cause of a problem.
- **Copeland Scroll UltraTech™ Compressor** – The Ultra Tech Compressor operates with 2 stages of cooling capacity to provide superior comfort and efficiency. Copeland's proven and simple design equates to years of comfort and reliability for the homeowner with virtually silent operation.
- **Durable, Attractive Cabinet** – Designed using galvanized steel with a polyester urethane finish. The 950 hour salt spray finish is 1.5 mil thick and resists corrosion 50% better than comparable units.
- **Copper Tube / Aluminum Fin Coils** – Both indoor and outdoor coils are designed to optimize heat transfer, minimize size and cost, and increase durability and reliability.
- **Permanently Lubricated Motor** – A heavy duty PSC motor for long lasting reliability and quiet operation. Requires no maintenance and is completely protected from rain and snow.
- **Full Port Service Valves** – Full port brass ball valves provide low pressure drop and ease of service. The valves are actuated by 1/4 turn full open to full close.
- **2-1/2" Pedestal Base** – The sturdy base keeps the bottom of the coil out of harms way. Secondly, the base has weep holes along the edge to allow the water from rain to flow away from the unit.
- **Swept-Wing Fan Blade**
- **Louvered Condenser Guard** – Durable metal guard protects the coil from yard hazards and extreme weather.
- **Removable Top Grille Assembly** – Allows ease of service from the top without disconnecting fan motor leads.
- **Low Pressure Switch** – Loss of charge protection ensures long compressor life. Auto-reset feature prevents nuisance service visits.
- **High Pressure Switch** – Protects against abnormally high system pressures. Auto-reset feature prevents nuisance service visits.
- **Liquid Line Filter Drier** – Included with unit, field installed.
- **One Piece Top/Orifice** – Designed for maximum airflow and quiet operation.
- **Easy Compressor and Control Access** – Designed to make servicing easier for the contractor, access panels are provided to all controls and the compressor from the side of the unit.
- **Warranty** – The best in the industry
 - 5 year limited parts
 - 2 year mileage
 - 2 year labor

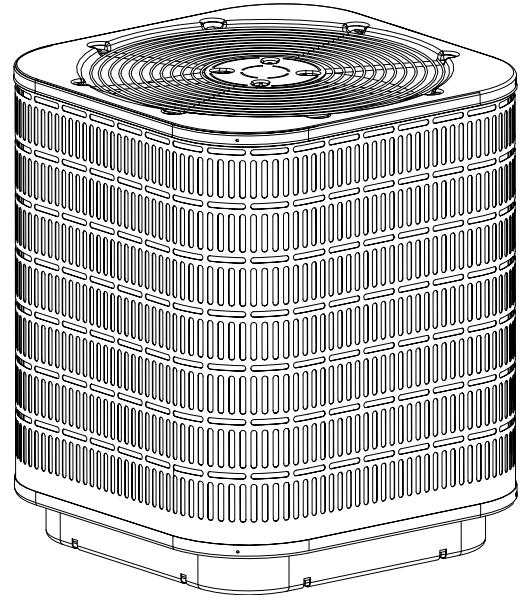

MODEL IDENTIFICATION CODES

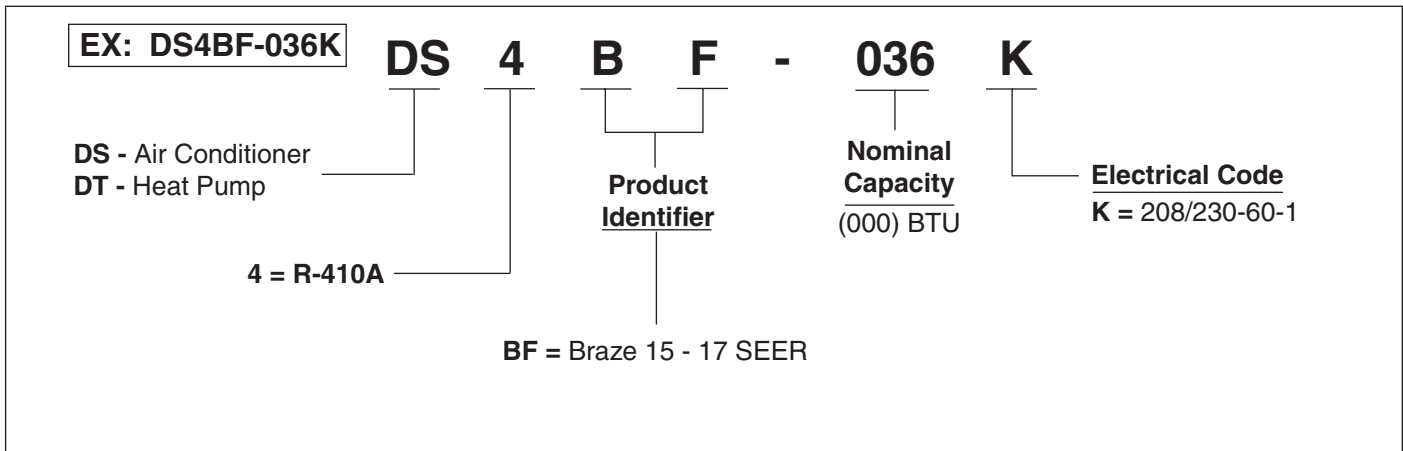

DIMENSIONS

AIR CONDITIONER OUTDOOR SECTION

DS4BF	024	036	048	060
H	34 1/2	42 1/2	42 1/2	42 1/2
W	30 1/2	30 1/2	30 1/2	30 1/2
D	30 1/2	30 1/2	30 1/2	30 1/2

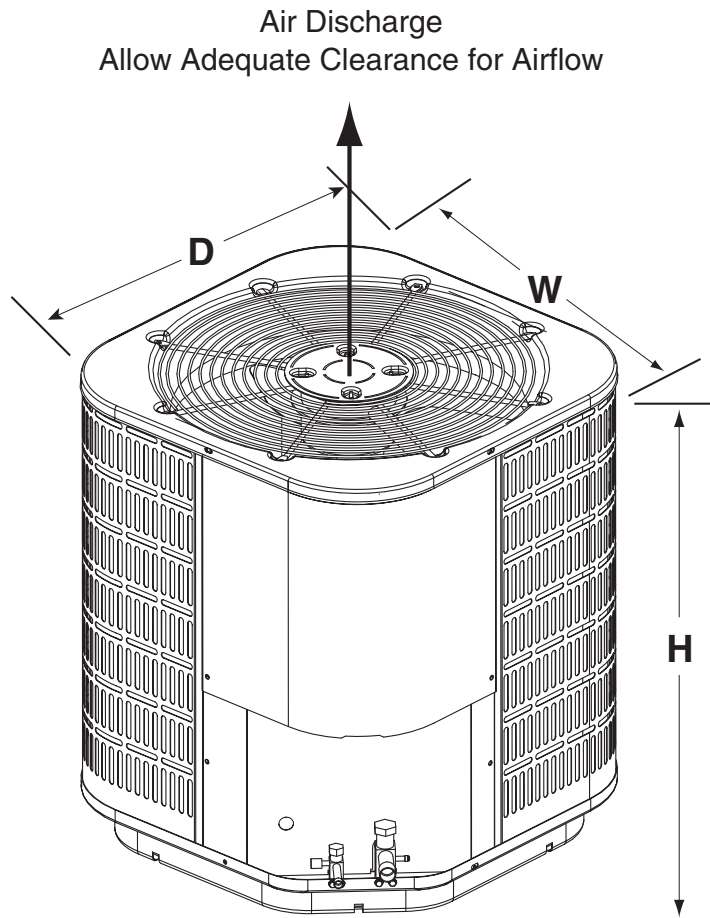

PHYSICAL AND ELECTRICAL SPECIFICATIONS / OUTDOOR UNITS

16 SEER — R-410A Extra High Efficiency — Single Phase

Model Number DS4BF		024	036	048	060	
Electrical Data	Volts-Cycles-Phase (1)	208/230-60-1	208/230-60-1	208/230-60-1	208/230-60-1	
	Total Amps	11.3	17.9	22.4	26.9	
	Delay Fuse Max. (2)	20	35	45	50	
	Min. Circuit Ampacity	13.9	22.1	27.7	33.3	
Condenser Data	Coil	Area	20.3	25.4	25.4	25.4
		Rows-FPI	2-18	2-18	2-18	2-18
		Tube Dia	3/8" O.D.	3/8" O.D.	3/8" O.D.	3/8" O.D.
	Fan Motor	Type	PSC	PSC	PSC	PSC
		Speeds	1	2	2	2
		Amps	1.0	1.3	1.3	1.3
		Lo/Hi Spd Watts	200	187/250	187/250	187/250
		HP	1/4	1/4	1/4	1/4
	Fan Blade	Dia-# Blades	24"- 2	24"- 2	24"- 2	24"- 2
		SCFM	3600	4000	4000	4000
	Compressor Data	RLA	10.3	16.6	21.1	25.6
		LRA	52	82	96	99
Refrigerant suction line O.D.(all length of liquid line are 3/8" O.D.)	0-24 ft.	3/4"	7/8" (4)	7/8"	7/8"	
	25-39 ft.	7/8"	1-1/8" (3)	1-1/8" (3)	1-1/8" (3)	
	40-75 ft.	7/8"	1-1/8" (3)	1-1/8" (3)	1-1/8" (3)	
Refrigerant charge (R-410A) in ounces for outdoor unit, indoor unit and 15' lineset.		192	264	232	248	
Weight Approximate (lbs.)	Net	248	260	270	284	
	Ship	260	272	282	296	

- (1) Operating voltage range: 187V minimum - 253 V maximum
- (2) HACR type circuit breakers may be used
- (3) Requires 1-1/8 to 7/8" reducer from unit to lineset.
- (4) Use of a 3/4" lineset will result in approximately 2% loss in capacity.

ACCESSORIES - Condensing Unit

Start Assist Kit - 912933

Provides additional starting torque for the compressor motor when operating with low line voltage or high operating temperatures.

COPPER WIRE SIZE — AWG (1% Voltage Drop)				
Supply Wire Length-Feet				Supply Circuit
200	150	100	50	Ampacity
6	8	10	14	15
4	6	8	12	20
4	6	8	10	25
4	4	6	10	30
3	4	6	8	35
3	4	6	8	40
2	3	4	6	45
2	3	4	6	50

Wire Size based on N.E.C. for 60° type copper conductors.

SYSTEM COOLING CAPACITIES

16 SEER — Extra High Efficiency — Single Phase

With this Coil							
Outdoor Unit Number DS4BF	Indoor Unit Number C4BA-	Low Speed Capacity (Btu/h)	High Speed Capacity (Btu/h)	SEER	EER	Low Speed SCFM	High Speed SCFM
024K	X24(C,U)-B+VSB	18000	24000	15.5	13.1	650	850
036K	X36(C,U)-B+VSB	25000	36000	16.0	12.5	720	1050
048K	X48(C,U)-C+VSB	35000	48000	16.2	12.5	1100	1595
060K	X60(C,U)-C+VSB	42000	57000	15.0	11.5	1170	1700

With this Air Handler							
Outdoor Unit Number DS4BF	Indoor Unit Number B4VM-	Low Speed Capacity (Btu/h)	High Speed Capacity (Btu/h)	SEER	EER	Low Speed SCFM	High Speed SCFM
024K	X24KB	18000	24000	15.5	13.1	650	850
036K	X36KB	25000	36000	16.0	12.5	730	1060
048K	X48KC	35000	48000	16.2	12.5	1070	1555
060K	X60KC	42000	57000	15.0	11.5	1150	1665

Air handlers and coils used in tables are designed and manufactured by NORDYNE.

COMFORT ALERT™ DIAGNOSTIC MODULE

Green POWER LED Indicates Voltage Is Present At The Power Connection Of The Module

Yellow ALERT LED Flashes To Indicate Fault Code

Red TRIP LED Indicates If Compressor Is Tripped Or Has No Power



Pass Through Ports Detect Run/Start Current; Spade Connectors Detect Tstat Demand and Pilot Voltage; Microprocessor Monitors Behavior To Determine Faults

Diagnostics Key Directs Service Tech To The Root Cause Of A Problem



CERTIFICATION APPLIES ONLY WHEN THE COMPLETE SYSTEM IS LISTED WITH ARI

We Encourage Professionalism



Through Technician Certification by NATE

271C-0606 (Replaces 271C-0506)