

DT4BF Series R-410A Ultra High Efficiency Heat Pump 15+ SEER Residential System 2 - 5 Ton Capacity

The DT4BF series now offers the choice of a heat pump that uses a more efficient and environmentally friendly refrigerant designated R-410A. The DT4BF Series of heat pumps offers exceptional performance as well as environmental protection. These models, when matched with our variable speed air handlers or variable speed equipped gas furnaces, offer a line of high quality heat pump systems rated up to 15+ SEER and 8.5 HSPF.

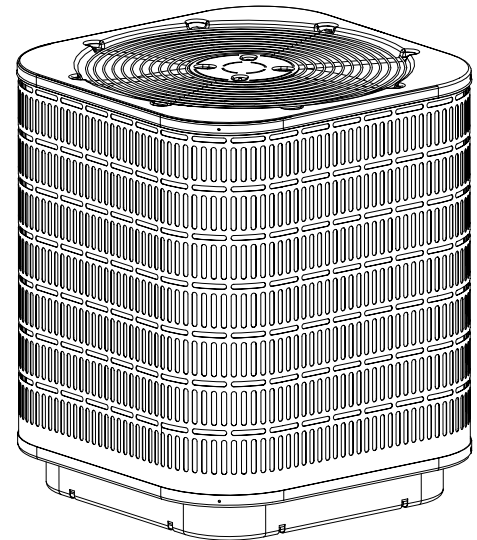

FEATURES and BENEFITS

- **R-410A Refrigerant** – Earth friendly non-ozone depleting refrigerant.
- **Comfort Alert™ Module** – Detects system and electrical problem conditions. A diagnostics key directs the service technician to the root cause of a problem.
- **Copeland Scroll UltraTech™ Compressor** – The Ultra Tech Compressor operates with 2 stages of heating and cooling capacities to provide superior comfort and efficiency. Copeland's proven and simple design equates to years of comfort and reliability for the homeowner with virtually silent operation.
- **Durable, Attractive Cabinet** – Designed using galvanized steel with a polyester urethane finish. The 950 hour salt spray finish is 1.5 mil thick and resists corrosion 50% better than comparable units.
- **Copper Tube / Aluminum Fin Coils** – Both indoor and outdoor coils are designed to optimize heat transfer, minimize size and cost, and increase durability and reliability.
- **Permanently Lubricated Motor** – A heavy duty PSC motor for long lasting reliability and quiet operation. Requires no maintenance and is completely protected from rain and snow.
- **Full Port Service Valves** – Full port brass ball valves provide low pressure drop and ease of service. The valves are actuated by 1/4 turn full open to full close.
- **Louvered Condenser Guard** – Durable metal guard protects the coil from yard hazards and extreme weather.
- **Removable Top Grille Assembly** – Allows ease of service from the top without disconnecting fan motor leads.
- **Swept-Wing Fan Blade**
- **2-1/2" Pedestal Base** – The sturdy base keeps the bottom of the coil out of harms way. Secondly, the base has weep holes along the edge to allow the water from rain to flow away from the unit.
- **Low Pressure Switch** – Loss of charge protection ensures long compressor life. Auto-reset feature prevents nuisance service visits.
- **High Pressure Switch** – Protects against abnormally high system pressures. Auto-reset feature prevents nuisance service visits.
- **Liquid Line Filter Drier** – Included with unit, field installed.
- **One Piece Top/Orifice** – Designed for maximum airflow and quiet operation.
- **Common Suction Service Port** – This port allows the contractor to read the suction pressure in all modes of operation without removing any panels, saving time and increasing serviceability.
- **Five Minute Restart Time Delay** – When the unit shuts down, a five minute delay keeps the unit from restarting, eliminating the highest cause for compressor failure.
- **Suction Accumulator** – Protection from liquid flood back and future compressor failures.
- **Hot Gas Muffler** – Reduces compressor noise and vibration.
- **Easy Compressor and Control Access** – Designed to make servicing easier for the contractor, access panels are provided to all controls and the compressor from the side of the unit.
- **Warranty** – The best in the industry.
 - 5 year limited parts
 - 2 year mileage
 - 2 year labor

MODEL IDENTIFICATION CODES

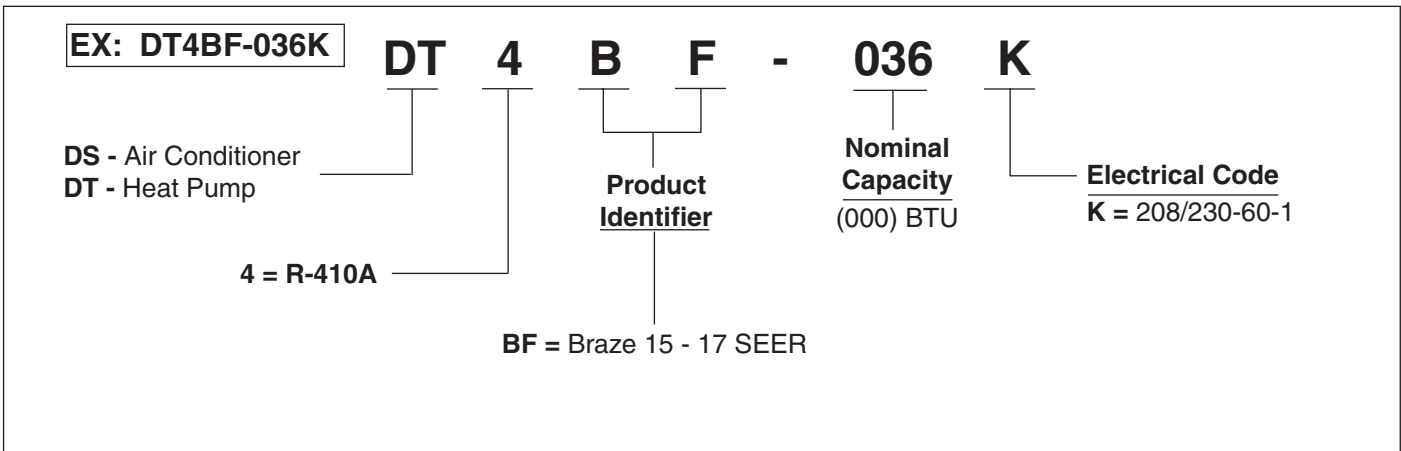

DIMENSIONS HEAT PUMP OUTDOOR SECTION

DT4BF	024	036	048	060
H	38 1/2	42 1/2	42 1/2	42 1/2
W	30 1/2	30 1/2	30 1/2	30 1/2
D	30 1/2	30 1/2	30 1/2	30 1/2

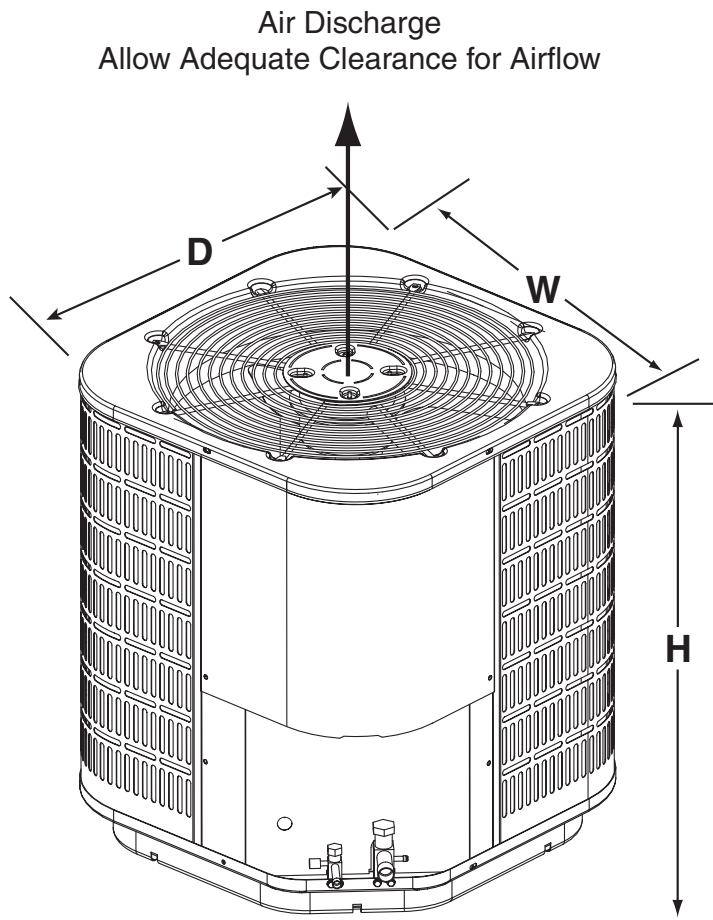

PHYSICAL AND ELECTRICAL SPECIFICATIONS / OUTDOOR UNITS

15+ SEER — R-410A Ultra High Efficiency — Single Phase

Model Number DT4BF			024	036	048	060
Electrical Data	Volts-Cycles-Phase (1)		208/230-60-1	208/230-60-1	208/230-60-1	208/230-60-1
	Total Amps		11.3	17.9	22.4	26.9
	Delay Fuse Max. (2)		20	35	45	50
	Min. Circuit Ampacity		13.9	22.1	27.7	33.3
Condenser Data	Coil	Area	22.8	25.4	25.4	25.4
		Rows-FPI	2-16	2-18	2-18	2-18
		Tube Dia	3/8" O.D.	3/8" O.D.	3/8" O.D.	3/8" O.D.
	Fan Motor	Type	PSC	PSC	PSC	PSC
		Speeds	1	2	2	2
		Amps	1.0	1.3	1.3	1.3
		Lo/Hi Spd Watts	200	187/250	187/250	187/250
		HP	1/4	1/4	1/4	1/4
	Fan Blade	Dia-# Blades	24"- 2	24"- 2	24"- 2	24"- 2
		SCFM	3600	4000	4000	4000
	Compressor Data	RLA	10.3	16.6	21.1	25.6
		LRA	52	82	96	99
Refrigerant suction line O.D.(all length of liquid line are 3/8" O.D.)		0-24 ft.	3/4"	7/8" (4)	7/8"	7/8"
		25-39 ft.	7/8"	1-1/8" (3)	1-1/8" (3)	1-1/8" (3)
		40-75 ft.	7/8"	1-1/8" (3)	1-1/8" (3)	1-1/8" (3)
Refrigerant charge (R-410A) in ounces for outdoor unit, indoor unit and 15' lineset.			208	272	272	272
Weight Approximate (lbs.)		Net	253	277	277	301
		Ship	265	289	289	313

(1) Operating voltage range: 187V minimum - 253 V maximum

(2) HACR type circuit breakers may be used

(3) Requires 1-1/8 to 7/8" reducer from unit to lineset.

(4) Use of a 3/4" lineset will result in approximately 2% loss in capacity.

ACCESSORIES - Condensing Unit

Start Assist Kit - 912933

Provides additional starting torque for the compressor motor when operating with low line voltage or high operating temperatures.

COPPER WIRE SIZE — AWG (1% Voltage Drop)				
Supply Wire Length-Feet				Supply Circuit Ampacity
200	150	100	50	
6	8	10	14	15
4	6	8	12	20
4	6	8	10	25
4	4	6	10	30
3	4	6	8	35
3	4	6	8	40
2	3	4	6	45
2	3	4	6	50

Wire Size based on N.E.C. for 60° type copper conductors.

SYSTEM HEATING AND COOLING CAPACITIES

15+ SEER — Ultra High Efficiency — Single Phase

		With this Coil								
Outdoor Unit Number DT4BF	Indoor Unit Number C4BA-	Cooling				Indoor CFM		Heating		
		Low Speed Capacity (Btu/h)	High Speed Capacity (Btu/h)	SEER	EER	Low Speed SCFM	High Speed SCFM	Low Speed Capacity (Btu/h)	High Speed Capacity (Btu/h)	HSPF
024K	X24(C,U)-B+VSB	18000	24000	15.2	13.0	640	840	18000	25000	8.2
036K	X36(C,U)-B+VSB	24000	35000	15.0	12.8	800	1155	25000	37000	8.2
048K	X48(C,U)-C+VSB	33000	46000	15.0	11.7	1100	1595	32000	43000	8.5
060K	X60(C,U)-C+VSB	39000	56000	14.0	11.1	1170	1700	38000	56000	8.4

		With this Air Handler								
Outdoor Unit Number DT4BF	Indoor Unit Number B4VM-	Cooling				Indoor CFM		Heating		
		Low Speed Capacity (Btu/h)	High Speed Capacity (Btu/h)	SEER	EER	Low Speed SCFM	High Speed SCFM	Low Speed Capacity (Btu/h)	High Speed Capacity (Btu/h)	HSPF
024K	X24KB	18000	24000	15.2	13.0	640	840	18000	25000	8.2
036K	X36KB	24000	35000	15.0	12.8	790	1140	25000	37000	8.2
048K	X48KC	33000	46000	15.0	11.7	1070	1555	32000	43000	8.5
060K	X60KC	39000	56000	14.0	11.1	1150	1665	38000	56000	8.4

Air handlers and coils used in tables are designed and manufactured by NORDYNE.

COMFORT ALERT™ DIAGNOSTIC MODULE

Green POWER LED Indicates Voltage Is Present At The Power Connection Of The Module

Pass Through Ports Detect Run/Start Current; Spade Connectors Detect Tstat Demand and Pilot Voltage; Microprocessor Monitors Behavior To Determine Faults

Yellow ALERT LED Flashes To Indicate Fault Code

Diagnostics Key Directs Service Tech To The Root Cause Of A Problem

Red TRIP LED Indicates If Compressor Is Tripped Or Has No Power



272C-0108 (Replaces 272C-0606)