

TECHNICAL SPECIFICATIONS

B5 Air Handler Variable Speed Blower Kits

Variable speed air delivery significantly improves overall system efficiency, indoor air quality, and sound levels. When matched with our condensing units a SEER rating of up to 16 is realized. An HSPF rating of up to 8.5 is realized on heat pumps. In addition to optimum efficiency, overall air quality is enhanced by minimizing air stratification. Reducing stratification in the space “mixes” the air from floor to ceiling creating a more uniform temperature. Filtration and humidity removal capabilities are improved as airborne particles and moisture are captured at a higher rate due to lower air velocity. Whisper quiet blower on/off sound quality complete the variable speed story. In summary, the variable speed blower kit will maximize system efficiencies, improve air quality, and reduce sound levels.

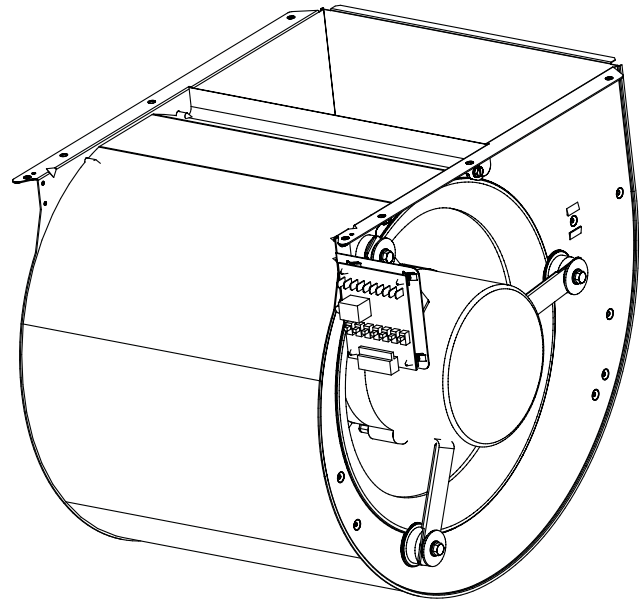

Features and Benefits

- Air conditioning and heat pump efficiencies up to 16 SEER and 8.5 HSPF.
- Easy to install, pre-wired and assembled. Slide into place and connect wires.
- Full perimeter lock seam housing construction for strength and durability.
- ECM variable speed motor technology allows for 12 selected cooling airflows and 4 heating airflows to match any application.
- Constant airflow to different static loads, motor automatically adjusts .
- Select from 4 separate delay profiles for increased efficiency and comfort.
- Extra low speed for “fan only” operation at 1/2 of selected air flow.
- Reduces air stratification (stagnant air). This results in improved air quality by optimizing humidity removal and filtration capabilities.
- Multi-poised – Can be used in horizontal, upflow and downflow applications.
- Extra quiet and smooth blower on and off cycles.
- Covered by the best warranty in the business.
- 11” blower wheel for maximum airflow.
- 2-Stage cooling enabled for use with R-410A two-stage A/C and heat pump models.
- Separate kits available for “A”, “B” and “C” cabinets.
 - “A” Cabinet 919325
 - “B” Cabinet 919326
 - “C” Cabinet 919327

Note: See current ARI directory for certified combinations and ratings.

SPECIFICATIONS

	A Cabinet	B Cabinet	C Cabinet
Nominal Blower Size	10 x 6	11 x 8	11 x 10
Maximum Motor HP	1/2	1/2	3/4
Motor Type	Programmable Variable Speed	Programmable Variable Speed	Programmable Variable Speed
Cooling CFM Range	540-1165	720 -1390	1075-2090
Heating Airflow Range*	700 - 1100	700 - 1100	700-1500
Approximate Shipping Weight	40 lbs	45 lbs	45 lbs

* Airflow is held constant regardless of external static pressure within the HP and RPM limits of the motor

The heart of the variable speed blower kit for the B5 Series air handler is the ECM motor. "ECM" stands for electronically commutated motor. The ECM consists of a brushless DC type motor with a microcomputer-based variable speed drive located in the end bell. This drive continuously monitors RPM and torque output of the motor. This information, along with a set of blower constants developed in NORDYNE's laboratory, is fed into pre-programmed algorithms in the microprocessor to determine the correct motor output required to maintain constant airflow regardless of external static pressure.

The microprocessor also stores delay profiles developed by NORDYNE to optimize the efficiency and performance of NORDYNE split system air conditioners and heat pumps. More than just on and off delays, the variable speed blower "steps" through intermediate airflow levels during the pre-programmed on and off profiles. The result is smoother, more efficient operation. The microprocessor also controls the rate of change of the motor's output to create quiet, gradual starts and stops. This kind of control is not possible with conventional motor technology.

1. SELECTING THE DELAY PROFILE

Delay profile selection controls the start-up and shut-down characteristics of the air handler. By varying the start-up and shut-down characteristics of the air handler the system can be optimized for energy efficiency, humidity control, and comfort.

"Delay A" has a two-step "on" delay. The blower will begin operation at 31% airflow for 30 seconds. After the two-step "on" delay has been completed, the blower operation will be 100% until the thermostat has been satisfied. "Delay A" also provides a 60 second "off" delay at 50% airflow.

"Delay B" has a single-step "on" delay at 50% airflow. "Delay B" also provides a 90 second "off" delay at 50% airflow.

The "De-Hum." delay profile may be used when humidity control is desired without the use of the optional humidistat. If the "De-Hum." delay profile is selected, the air handler will run at 75% airflow for the first 10 minutes of each cooling cycle.

2. OPTIONAL HUMIDISTAT

The humidistat senses when humidity in the return air stream is above a preset level (field adjustable) and sends a signal to the motor to reduce the airflow so that more moisture may be removed until the humidity level drops.

ACCESSORIES

Accessory Kit Description	Size			Order Number
	A	B	C	
Humidistat	X	X	X	913769

A-CABINET						B-CABINET						C-CABINET														
CFM	Switch Number				Nominal Capacity		CFM	Switch Number				Nominal Capacity		CFM	Switch Number				Nominal Capacity							
	1	2	3	4	1.5	2.0		2.5	3.0	1	2	3	4		1.5	2.0	2.5	3.0	3.5	4.0	1	2	3	4	3.0	3.5
540	0	0	0	1			720	0	0	0	1			1075	0	0	0	1								
600	0	0	0	0			800	0	0	0	0			1135	1	0	0	1								
660	0	0	1	0			850	1	0	0	1			1225	0	0	0	0								
715	1	0	0	1			880	0	0	1	0			1295	1	0	0	0								
790	1	0	0	0			945	1	0	0	0			1380	0	0	1	0								
870	1	0	1	0			1040	1	0	1	0			1460	1	0	1	0								
915	0	1	0	1			1085	0	1	0	1			1525	0	1	0	1								
955	1	1	0	1			1140	1	1	0	1			1625	1	1	0	1								
1015	0	1	0	0			1205	0	1	0	0			1740	0	1	0	0								
1060	0	1	1	0			1265	1	1	0	0			1860	1	1	0	0								
1075	1	1	0	0			1325	0	1	1	0			1960	0	1	1	0								
1165	1	1	1	0			1390	1	1	1	0			2090	1	1	1	0								

Table 1. Airflow selection for Variable Speed Models

