

## Electric Central Furnace - Blower & Relay

# Installation Instructions

For Models E(1,2)E(H,B) Series

The p/n 902986 2-wire and p/n 902987 A/C Heat Pump (4 to 7 wire) Relay Boxes install with current models of the E1 and E2 NORDYNE electric furnaces. The 2-wire Relay Box has control switches that are operable through an opening in the furnace door.

### Important Information

Read all instructions carefully before starting the installation. Specifications or designs are subject to change or to discontinuance without notice and without incurring obligations.

#### **⚠ WARNING:**

Improper installation may damage equipment, can create a hazard, and will void the warranty.

#### **⚠ DANGER:**

Shut off electrical supply to the furnace at the household breaker box to prevent electrical shock which could cause personal injury.

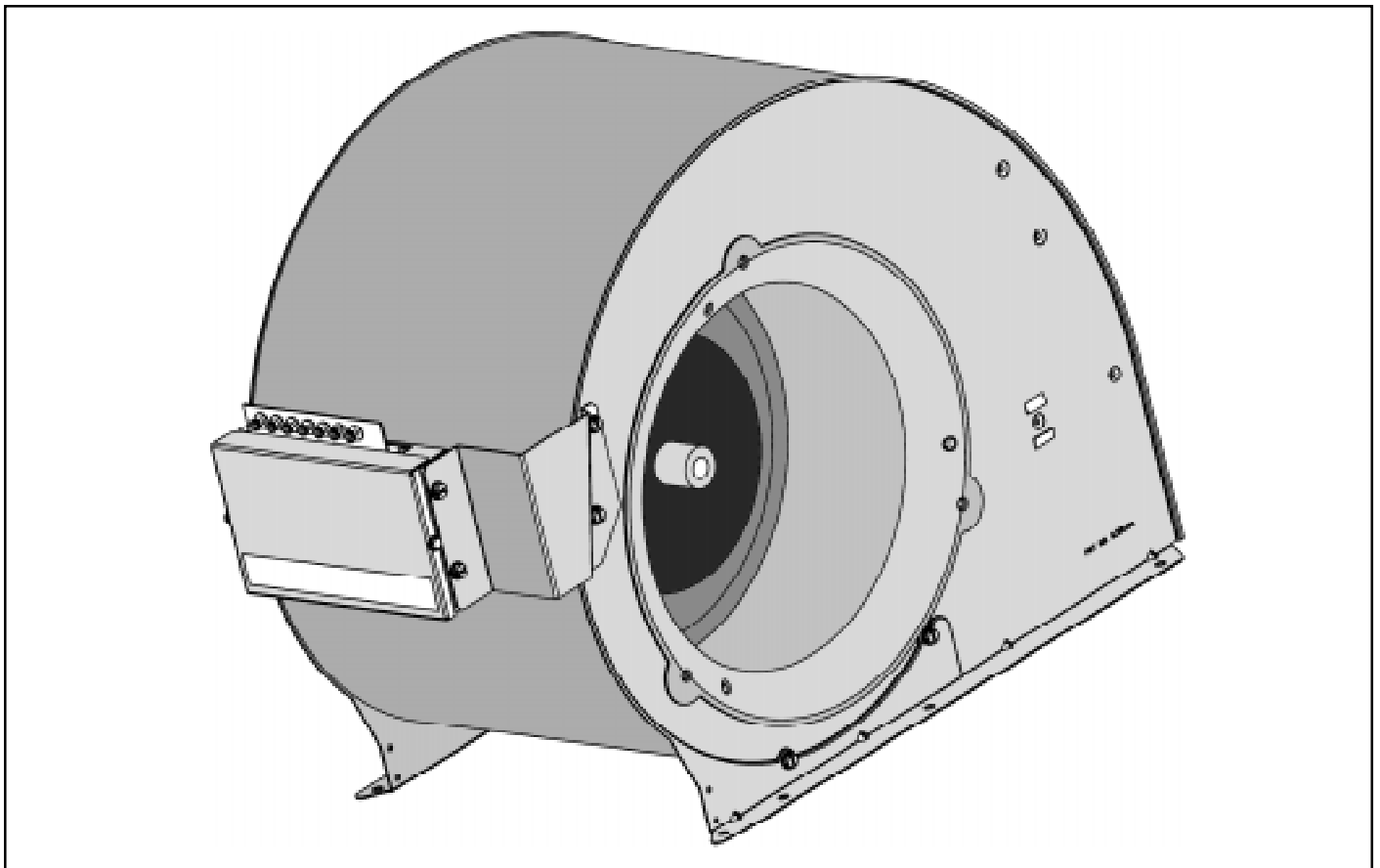

These instructions are primarily intended to assist qualified individuals experienced in the proper installation of heating and/or air conditioning appliances. Some local codes require licensed installation/service personnel for this type of equipment. Read all instructions carefully before starting the installation.

# Table of Contents

	Page
Installation .....	3
Blower Selection .....	3
Blower Speed Selection .....	3
System Operation .....	4
Replacement Parts .....	5
System Wiring .....	6
Circuit Board Schematics .....	7

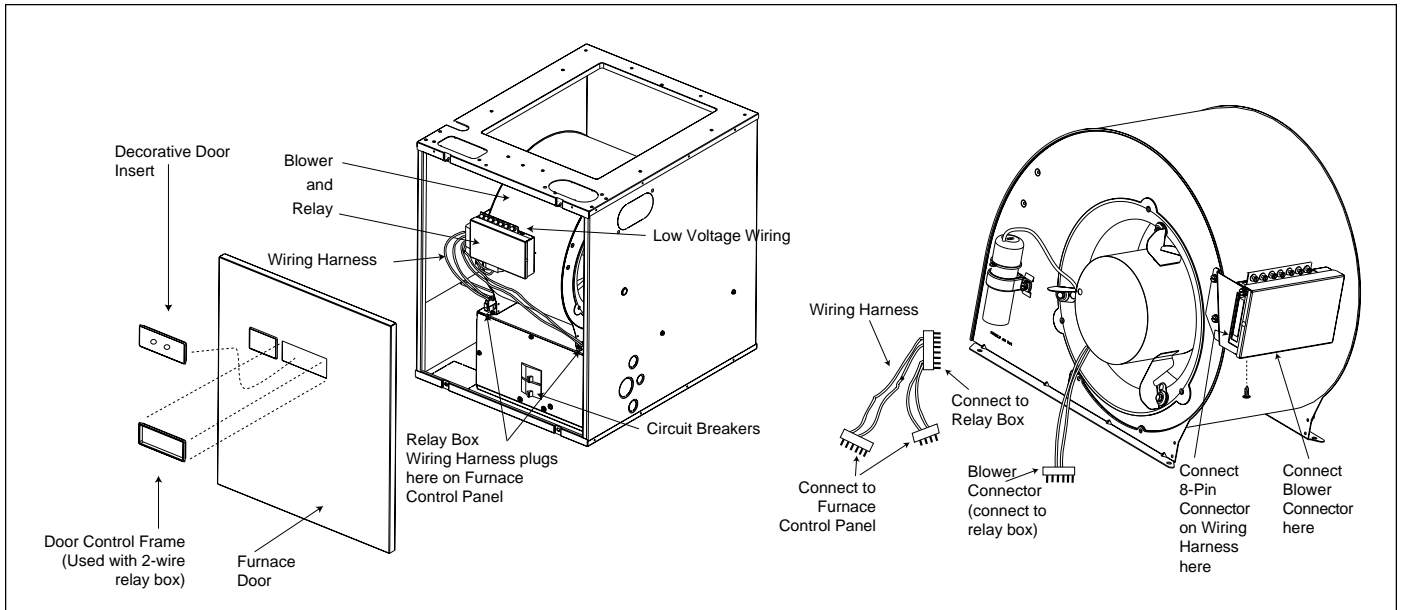

**Figure 1. E1E(-) Series Electric Furnace**

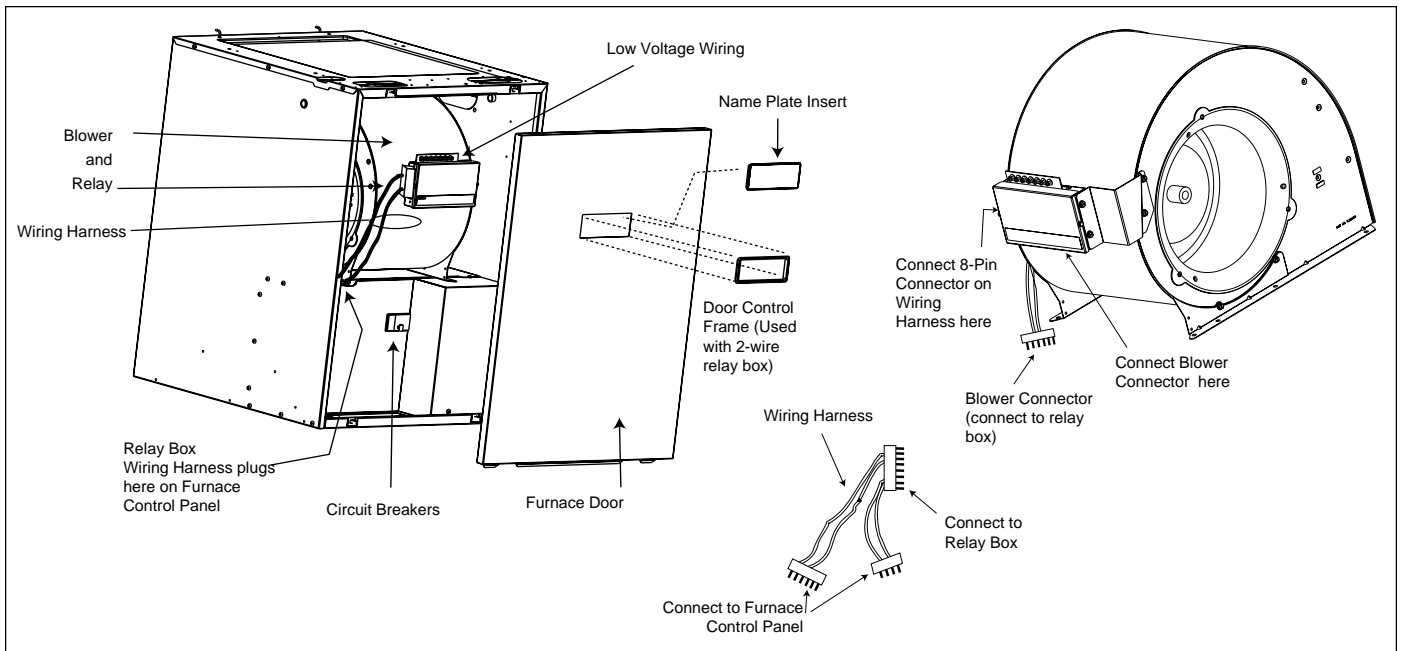

**Figure 2. E2E(-) Series Electric Furnace**

## Installation Sequence for Models E(1,2) E(H,B) Series Electric Furnace (See Figures 1 or 2)

Prior to installing a relay box in the NORDYNE furnace, be sure to install the correct A/C system equipment as outlined on the furnace options label.

1. Remove the furnace door by pulling outward either from the top or the top side of the door. Switch the circuit breaker(s) to the OFF position. (See Figure 1 or 2 for the circuit breaker location.)

Before installing the relay box remove the blower and install the cabinet insulation kit for furnaces that are not factory equipped with this package. Refer to the instructions supplied with the kit for proper installation.

2. **E(1,2)EH Models:** All E(1,2)EH models require a relay box when adding an air conditioner or heat pump.

**E(1,2)EB Models:** E(1,2)EB models using a 2-wire thermostat require a relay box (2-wire) when adding an air conditioner.

**Blower Selection:** See the furnace Installation Instructions for the correct air conditioning or heat pump available with the factory installed furnace blower. Change out the blower when needed.

3. Remove the cover from the relay box by removing the screw from each side.

### Blower Speed Selection:

- **HEATING** - Move the orange wire on the circuit board to one of the four quick-connects labeled with heating blower speeds.
- **COOLING** - Move the violet wire on the circuit board to one of the three quick-connects labeled with cooling blower speeds.
- **TWO SPEED BLOWER** - Connect the orange wire (heating) to the L (low) quick-connect for low speed. Connect the violet wire (cooling) to the ML (medium low) quick-connect for high speed.
- **FOUR SPEED BLOWER** - See Table 1 for the appropriate speed connections for the E1E(-) and Table 2 for the E2E(-).

Reattach the relay box cover using the two screws previously removed.

### IMPORTANT:

For the **2-wire relay box** (only after the cover has been reattached):

- a. Attach two red caps (provided in plastic bag) to the switches that stick through the bezel on the sheet metal cover (see Figure 3, items 7 and 8).

Furnace Operation (orange wire)			Air Conditioning/Heat Pump Operation (violet wire)			
<b>Furnace Model No.</b>	-010, -012,	-015, -017, -020, -023	<b>Air Conditioning Model No.</b>	-024	-030, -036	-042, -046, 048
<b>Relay Box Speed Terminal (minimum)</b>	L	ML	<b>Heat Pump Model</b>	-018	-024, -030	-036, -042, -048
			<b>Relay Box Speed Terminal</b>	ML	MH	H

**NOTE:** See furnace installation instructions for nominal air deliveries.

**Table 1. E1E(-) Heating and Cooling Speed Setting Positions -4 Speed Blower**

Furnace Operation (orange wire)			Air Conditioning/Heat Pump Operation (violet wire)			
<b>Furnace Model No.</b>	-010, -012, -015	-017, -020, -023	<b>SEE FURNACE BLOWER LABEL FOR APPROPRIATE SPEED CONNECTIONS</b>			
<b>Relay Box Speed Terminal (minimum)</b>	L	ML				

**NOTE:** See furnace installation instructions for nominal air deliveries.

**Table 2. E2E(-) Heating and Cooling Speed Setting Positions -4 Speed Blower**

**For E2E(-) furnace only:**

- b. Attach the appropriate brand label to the sheet metal cover so that it may be seen through the door control frame (see Figure 2) in the furnace door when it is replaced.
  - c. Attach the foam “standoff” to the bottom corner on the back side of the relay box opposite the side where the bracket is attached (See Figure 2A). This standoff will prevent movement of the relay box when the homeowner adjusts the switches.
4. **Relay Box Attachment (See Figures 1 or 2):** Attach the mounting bracket to the appropriate side of the relay box. Attach the relay box to the side of the blower housing.

Insert the relay/blower assembly into the furnace by sliding it into the furnace and under the mounting tabs. Secure the blower in place by using the blower screws previously removed.

5. **Relay Box Connection (See Figure 1 or 2):**

- Unplug the blower connector and the thermostat pigtail leads connector from the furnace control panel.
  - Plug the two different 6-circuit connectors on the relay box wiring harness into their corresponding locations on the furnace control panel (where the blower and thermostat leads connectors were just removed).
  - Plug the 8-circuit connector on the other end of the wiring harness into the side of the relay box.
  - Plug the 6-circuit blower connector into the bottom of the relay box.
6. **Low Voltage Wiring (See Figure 1 or 2):** Bring in the low voltage field wires from the thermostat and air conditioning or heat pump unit and attach them to the screw terminals located at the top of the relay box. **See Figure 5 for System Wiring.**
7. Switch the circuit breaker(s) to the ON position. The unit is now ready for operation.

## System Operation —

### For the AC/Heat Pump Relay Box

**Heating:** Set the furnace system switch to AUTO, the thermostat system switch to HEAT, and the thermostat fan switch to AUTO.

**Cooling:** Set the furnace system switch to AUTO, the thermostat system switch to COOL, and the thermostat fan switch to AUTO.

**Emergency Heat:** (Used with a heat pump only.) Set the furnace system switch to AUTO, the thermostat system switch to EMERGENCY HEAT, and the thermostat fan switch to AUTO.

**Continuous Air Circulation:** Set the thermostat fan switch to ON.

**Shut off System:** Set the thermostat system switch to OFF and set it to the lowest temperature setting. Set the furnace system switch to OFF and shut off all power to the air conditioner.

### For the 2-Wire Relay Box

**Heating:** Set the furnace system switch to AUTO, the temperature switch (on the relay box) to HEAT, and the fan switch (on the relay box) to AUTO.

**Cooling:** Set the furnace system switch to AUTO, the temperature switch (on the relay box) to COOL, and the fan switch (on the relay box) to AUTO.

**Continuous Air Circulation:** Set the fan switch (on the relay box) to ON.

**Shut off System:** Set the temperature switch (on the relay box) to OFF and set the thermostat to the lowest temperature setting. Set the furnace system switch to OFF and shut off all power to the air conditioner.

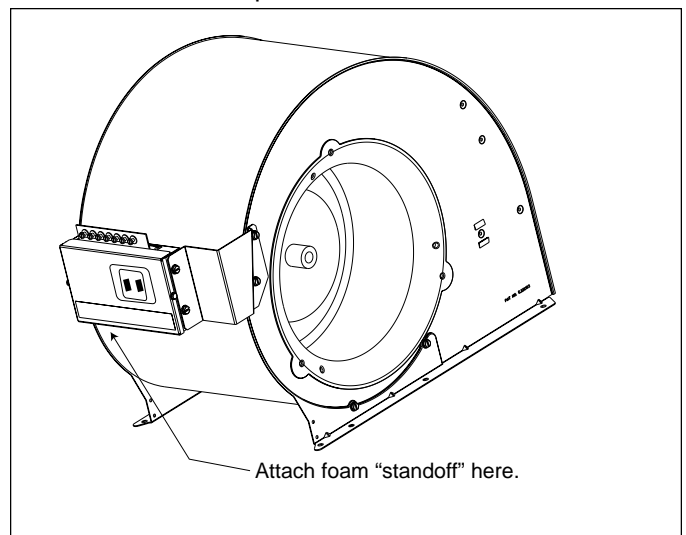

**Figure 2A. E2E(-) Electric Furnace with 2-wire Relay Box**

### Blower & Relay Replacement Parts List

ITEM #	PART #	DESCRIPTION	902986	902987	ITEM #	PART #	DESCRIPTION	902986	902987
1	375950	Cover (2 Wire)	1		4	259200	Wire Harness	1	1
	375951	Cover (AC/HP)		1	5	376050	Mounting Bracket, E1	1	1
2	375960	Box, Relay	1	1	6	380790	Mounting Bracket, E2	1	1
3	624567	2 Wire Relay Circuit Board (includes items 6 & 7)	1		7	669084	Bezel	1	
	624568	AC/HP Relay Circuit Board		1	8	632278	Switch Cap	2	

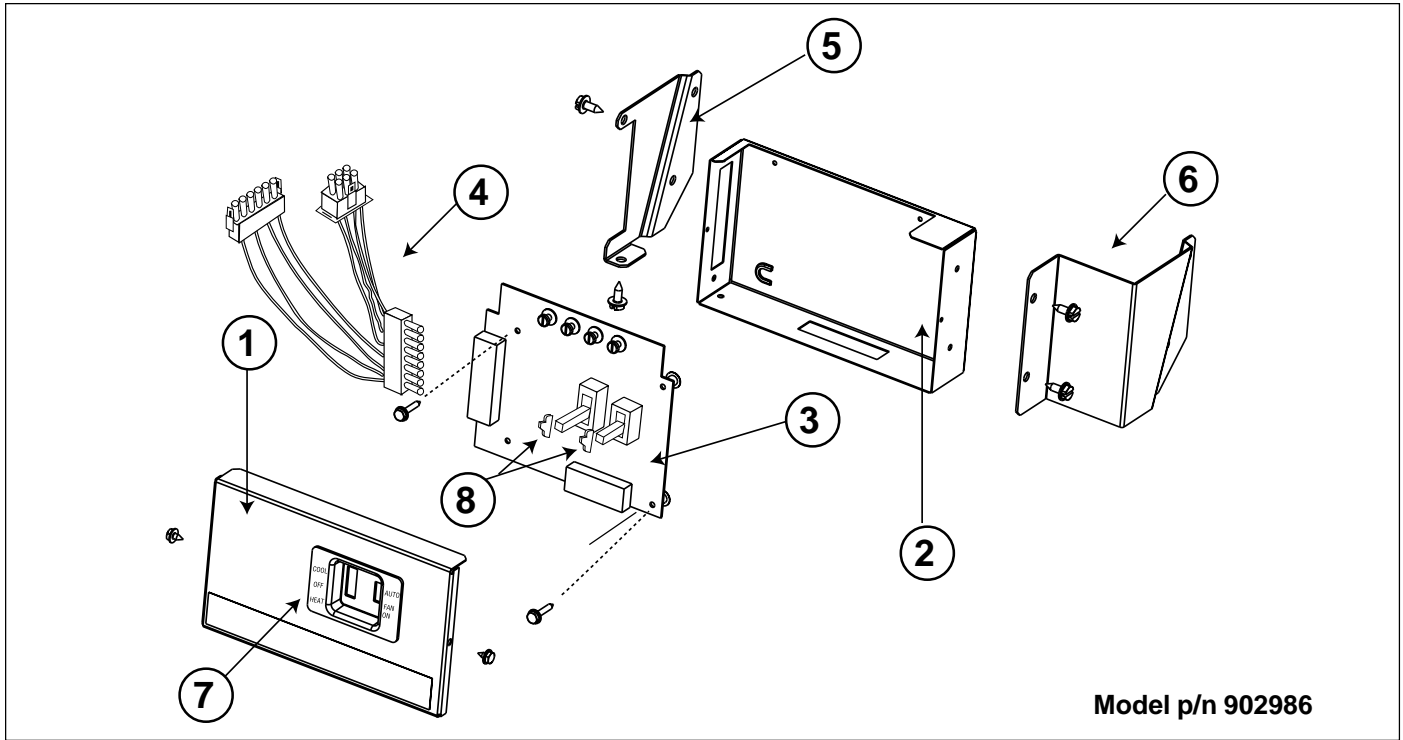

**Figure 3. 2-Wire Relay Box Exploded View**

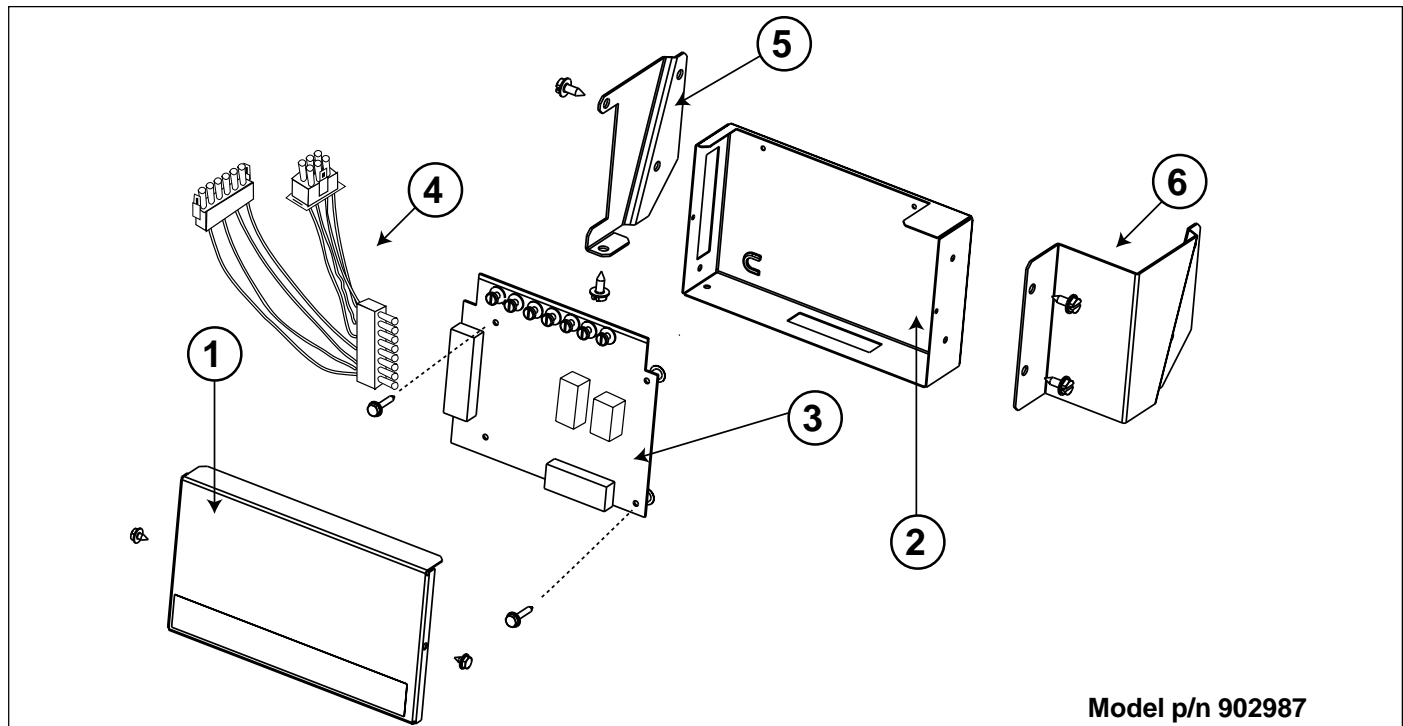

**Figure 4. A/C Heat Pump Relay Box Exploded View**

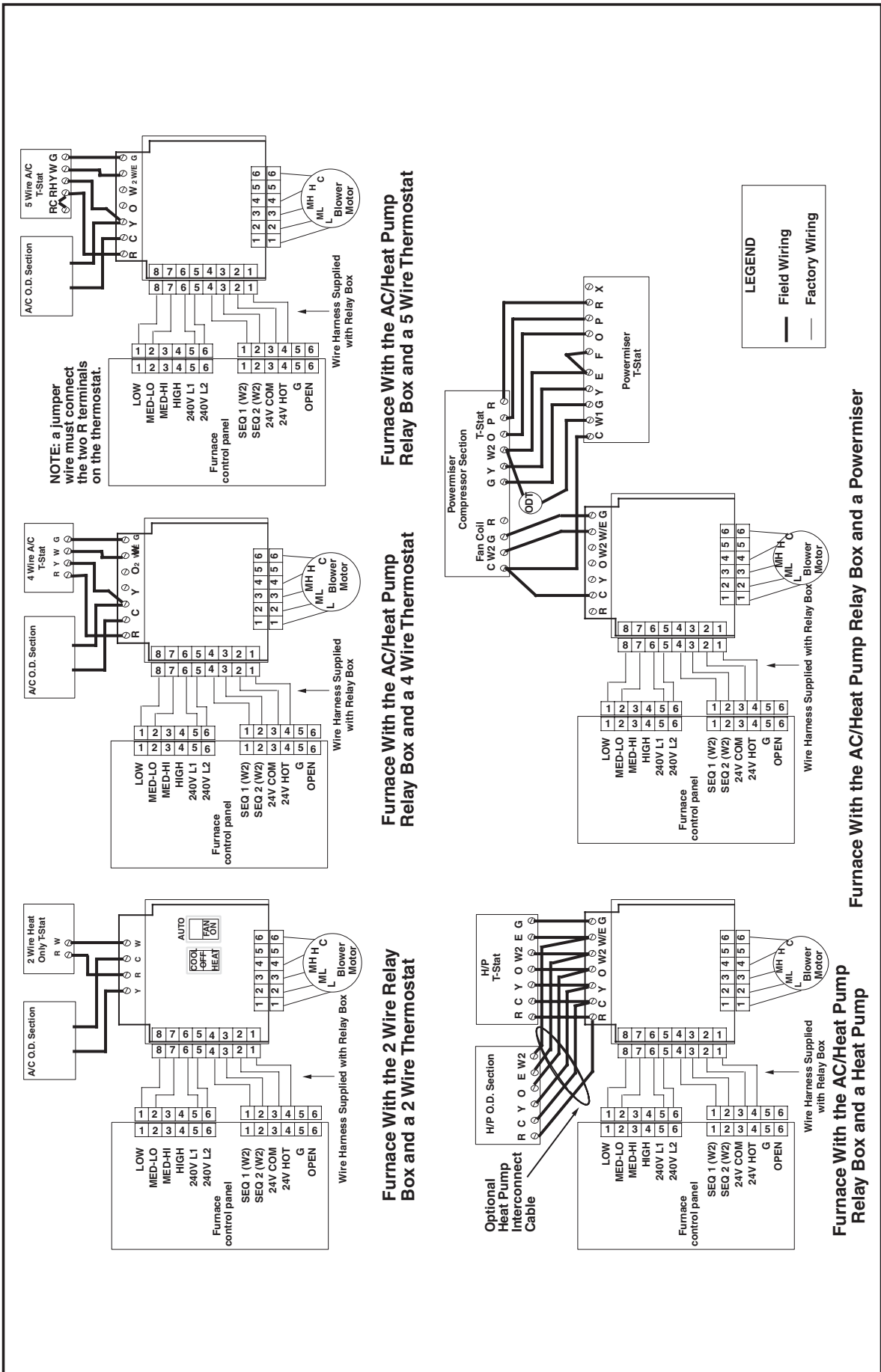
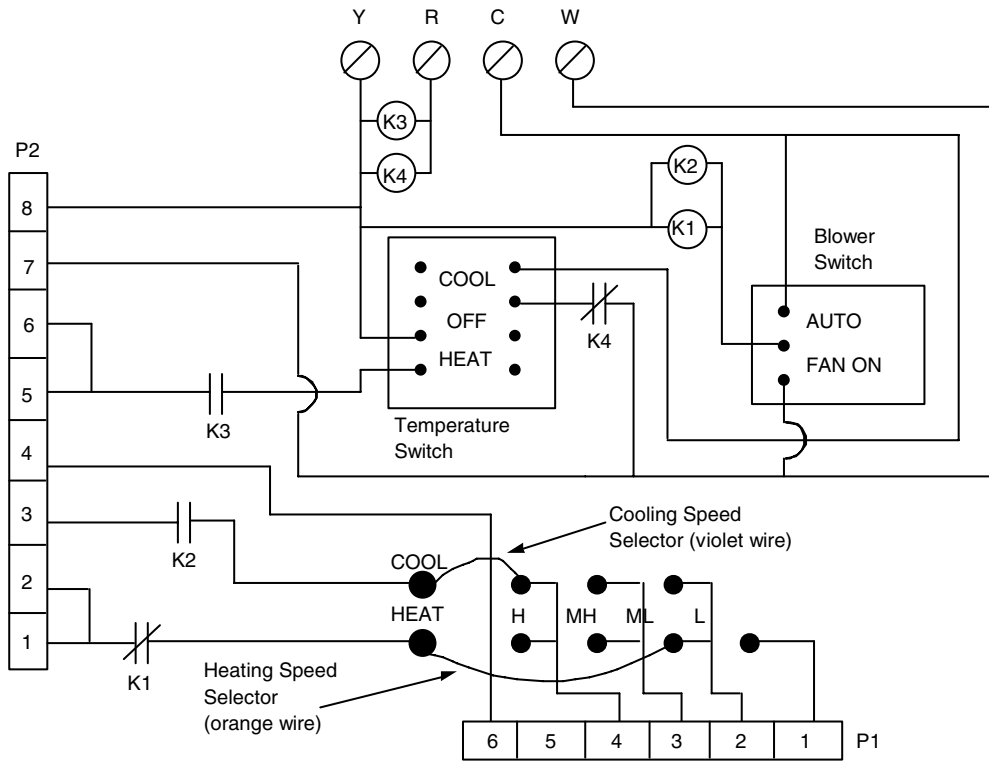

Figure 5. System Wiring

### 2 Wire Circuit Board (used in relay box 902986)



### AC/Heat Pump Circuit Board (used in relay box 902987)

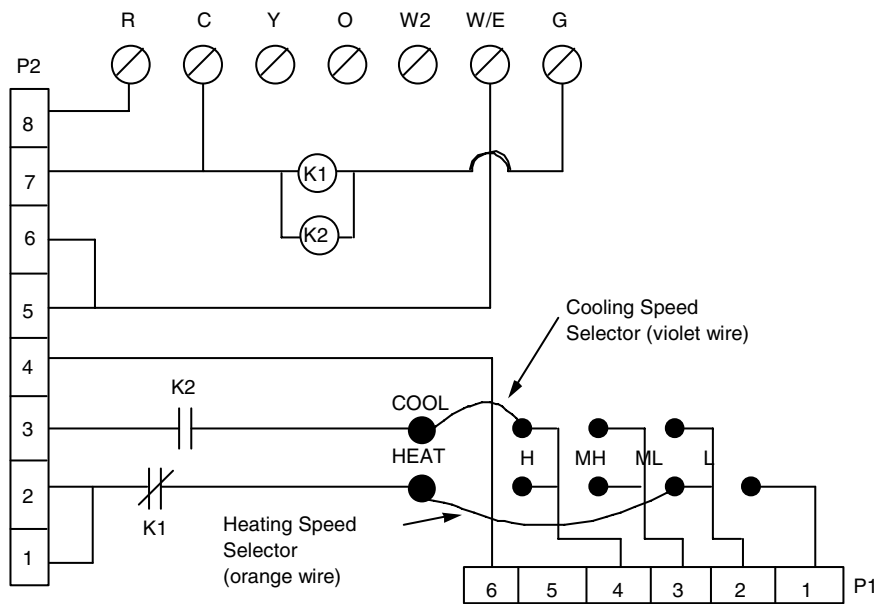

Figure 6. Wiring Schematics



**707545A**

O'Fallon, MO

**NORDYNE**

**707545A** (Replaces 7075450)  
Specifications and illustrations subject to change without  
notice and without incurring obligations. Printed in  
U.S.A. (06/06)