

Electric Furnace Coil Cabinet

Installation Instructions

For Use with E2 Series Electric Furnaces
Cabinet P/N 902976

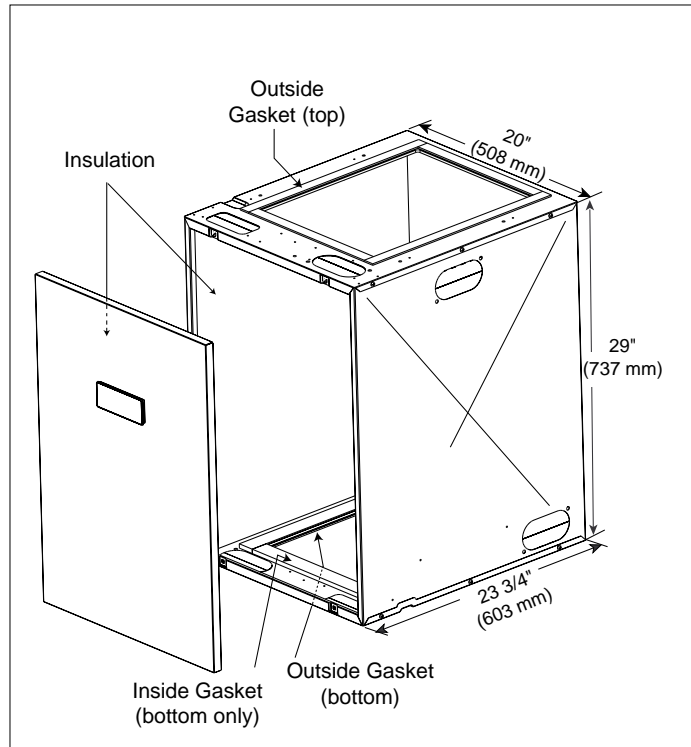

Figure 1. Coil Cabinet

INTRODUCTION

This coil cabinet is designed for upflow or downflow installations.

The cabinet is factory equipped with insulation, and to assure a sealed fit with the electric furnace, the outside top and bottom are factory equipped with gasketing (see Figure 1).

Review the furnace installation instructions for specific details on return air, filtering systems, and installation requirements before proceeding.

TYPICAL INSTALLATION OF UPFLOW SYSTEMS

NOTES:

- Systems may be installed with non-ducted or ducted return air.
- Return air provisions and filters are not provided with the coil cabinet; the additional accessory upflow stand provides both the return air and filtering systems and must be used for non-ducted return air unless additional provisions are made in the home.

- Remove refrigerant line knockouts only when installing indoor coil of a air conditioning or heat pump system. Refer to coil instructions for further coil installation details.

Non-Ducted Return Air System

1. After meeting all requirements from the furnace installation instructions, position coil cabinet, with inside gasketed surface toward bottom, on top of optional upflow stand or mounting platform (See Figure 2). Ensure gasket on outside of cabinet remains intact (See Figure 1). Secure with three or more fasteners at holes provided.
2. Position furnace onto coil cabinet in upflow mode and secure with two or more fasteners at holes provided ensuring gasket on outside of cabinet remains intact.
3. Use optional upflow duct connector or field supplied connector to attach furnace to overhead supply duct.

Ducted Return Air System

1. After meeting all requirements from the furnace installation instructions, mark floor opening(s) as shown in Figure 3.
 - a. Provide minimum clearances at rear and left side walls of closet for installation of furnace and wiring.
 - b. Cut floor opening on outside edge of marked line so that opening is slightly larger than area marked.

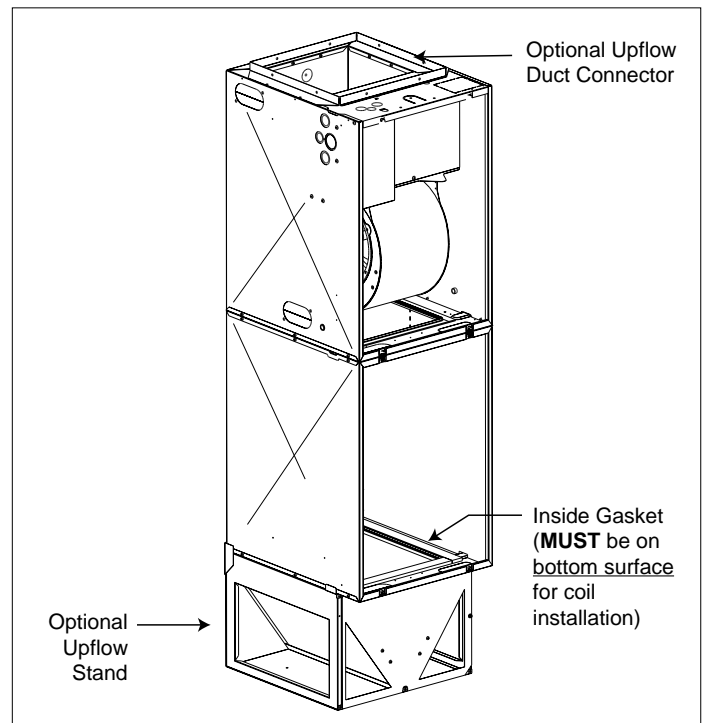

Figure 2. Upflow Installation

- c. Additional provisions may be necessary for optional air conditioning if refrigerant lines are installed other than at the front of the furnace.
2. Position coil cabinet, with inside gasketed surface toward bottom (see Figure 2), over floor cutout and secure with three or more fasteners ensuring gasket on outside of cabinet remains intact. (See Figure 1.)
3. Position furnace onto coil cabinet and secure with two or more fasteners ensuring gasket on outside of cabinet remains intact.
4. Use optional upflow duct connector or field supplied connector to attach furnace to overhead supply duct.

TYPICAL INSTALLATION OF DOWNFLOW SYSTEMS NOTES:

- Systems may be installed with non-ducted or ducted return air.
- Filters are not provided with coil cabinet.
- Remove refrigerant line knockouts only when installing indoor coil of a air conditioning or heat pump system. Refer to coil instructions for further coil installation details.

Non-Ducted Return Air System (Alcove or Closet)

NOTE: The return air grille mounting frame is not needed in this application since the filter will be accessed through the coil cabinet door. The wall mount grille is recommended in place of the grille and frame assembly.

1. After securing the furnace as stated in its installation instructions (with the exception of the attachment of the return air grille mounting frame), position coil cabinet,

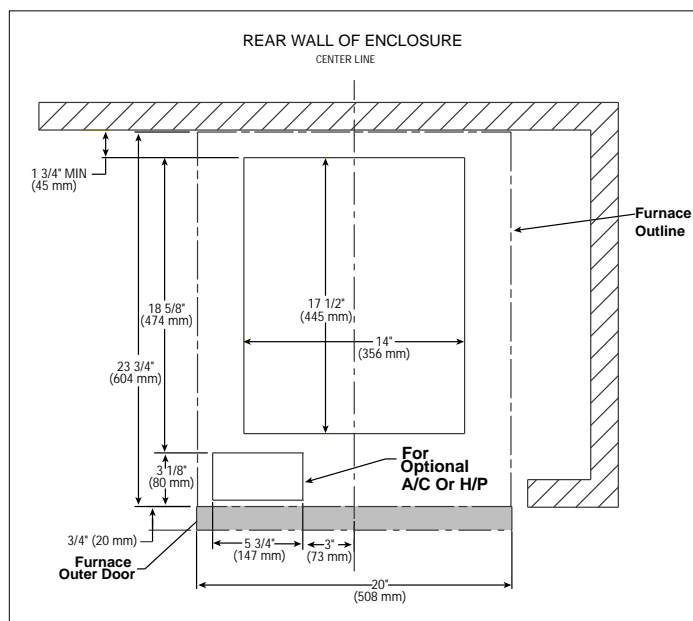

Figure 3. Floor Openings.

with inside gasketed surface toward bottom, on top of furnace (See Figure 4). Ensure gasket on outside of cabinet remains intact. Secure with two or more fasteners at holes provided.

2. Remove filter and filter retainer from furnace and install in top of coil cabinet. Blower may need to be removed in order to remove filter retainer from furnace.
3. Ensure that the duct system is properly sized so as to account for any additional external static pressure produced from this more restrictive filtering method with a coil.

Ducted Return Air System (Alcove or Closet)

1. After securing the furnace as stated in its installation instructions (with the exception of the attachment of the return air grille mounting frame), position coil cabinet, with inside gasketed surface toward bottom, on top of furnace (See Figure 4). Ensure gasket on outside of cabinet remains intact (see Figure 1). Secure with two or more fasteners at holes provided.
2. Connect the field fabricated duct to top of coil cabinet ensuring gasket on outside of cabinet remains intact.
3. A field supplied filter with a minimum unrestricted medium area of 324 square inches must be installed in the duct above coil and must be accessible for monthly cleaning or replacement by the homeowner.

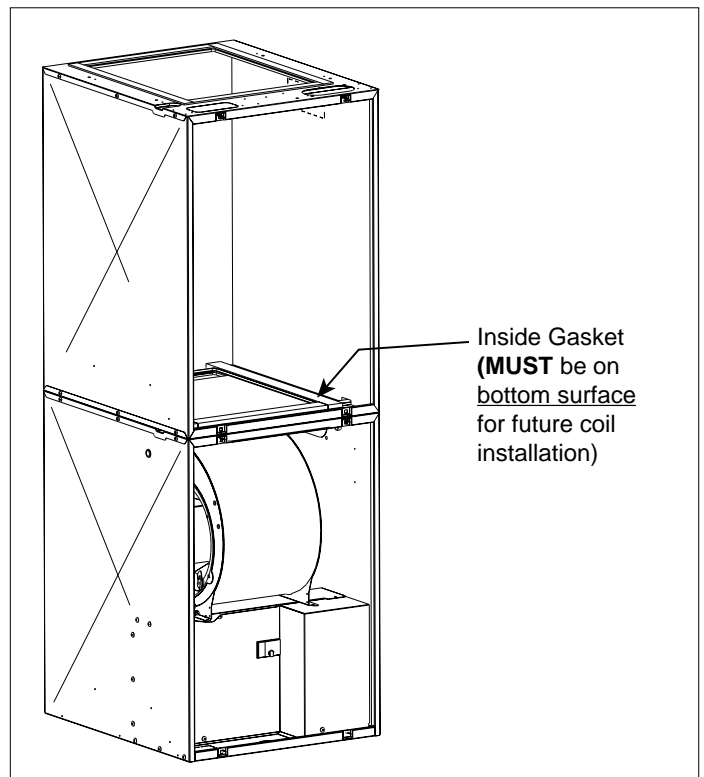

Figure 4. Downflow Installation