

Installation Instructions

Anti-Short-Cycle Timer Kit Part No. 914096

INTRODUCTION

These instructions are primarily intended to assist qualified individuals experienced in the proper installation of heating and / or air conditioning appliances. Before beginning the installation, read these instructions thoroughly and follow all warnings and cautions in the instructions and on the unit. Improper installation, service, adjustment, or maintenance can cause explosion, fire, electrical shock, or other conditions which may result in personal injury or property damage.

The Anti-Short-Cycle Timer Kit is designed as a replacement for an integral, contactor mounted, anti short-cycle timer. The kit consists of a remote mount timer, wires for attachment, and template for locating mounting holes. The timer provides a five minute start up delay anytime there is an interruption on the "Y" lead. The delay allows system pressures to equalize so that the compressor does not have to start against high pressures. The timer supplied in this kit has an additional three second interrogation feature which keeps the compressor delay from initiating unless continuity is lost on the "Y" lead for more than three seconds.

INSTALLATION SEQUENCE

⚠ WARNING:
To avoid risk of electric shock, personal injury, or death, disconnect electrical power to the unit before performing any maintenance or service.

1. Disconnect all power to the unit.
2. Remove and set aside the two screws that attach the control box cover to the unit.
3. Remove the control box cover by pulling out and down at the bottom of the cover.
4. Locate the current timer that is snapped on to the contactor. Remove the timer and all of the wires attached to it, including the yellow thermostat pigtail. Also disconnect the black wire that connects the contactor coil to the thermostat and discard.
5. Using the template provided, drill three (3) 0.187 diameter holes for the (3) plastic stand-offs to snap into in the low voltage area above the low voltage divider. Locate the timer as close to the grommet in the low voltage divider as you can without causing any wire routing problems.
6. Using the wires provided, wire the timer as shown in Figure 1.
7. Route the red and black wire through the grommet and connect one wire to each side of the contactor coil.
8. Connect the thermostat wires to the short yellow and black pigtails connected to the new timer. "Y" should be connected to the yellow wire and "X" or "C" connected to the black wire.
9. Replace the control box cover and screws.
10. Restore power to the unit.

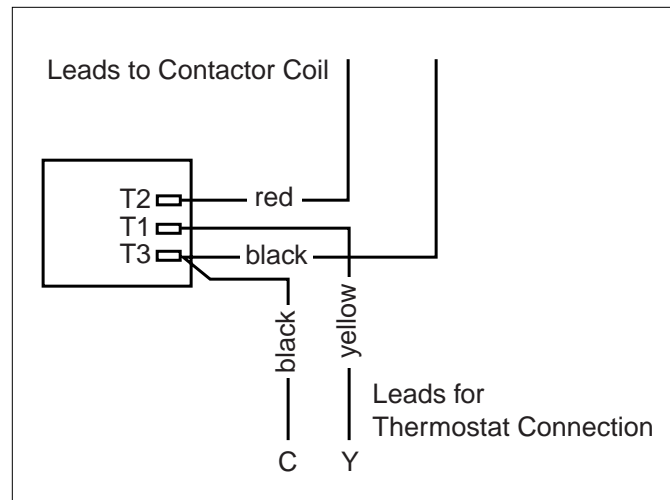

Figure 1. Wiring Schematic for Remote Anti-Short-Cycle Timer