

Direct Vent (Sealed Combustion) Forced Air Gas Furnaces

Installation Instructions

M2RC Series 90+ Upflow Condensing Furnace

M2RL Series 90+ Downflow Condensing Furnace

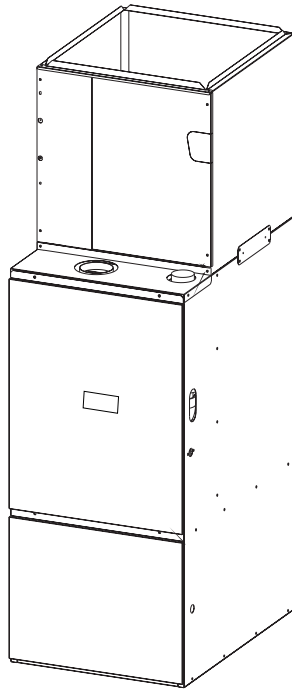

Upflow Model

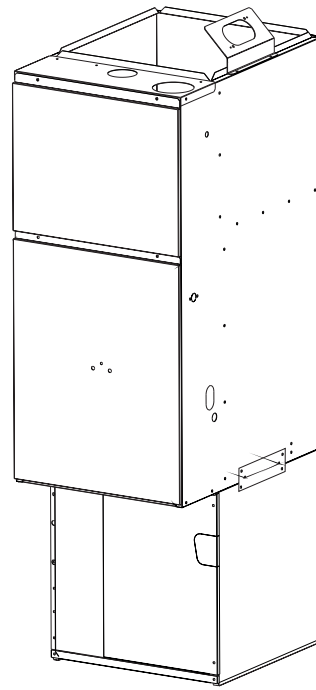

Downflow Model

WARNING:

Improper installation, adjustment, alteration, service, or maintenance can cause injury or property damage.

Refer to this manual for assistance. For additional information consult a qualified installer, service agency, or the gas supplier.

FOR YOUR SAFETY

Do not store or use gasoline or other flammable vapors and liquids in the vicinity of this or any other appliance.

WHAT TO DO IF YOU SMELL GAS

- Do not try to light any appliance.
- Do not touch any electrical switch; do not use any phone in your building.
- Immediately call your gas supplier from a neighbor's phone. Follow the gas supplier's instructions.
- If you cannot reach your gas supplier, call the fire department.
- Extinguish any open flame.

WARNING: Danger. Only qualified service personnel shall be used to install and provide maintenance to this appliance.

DO NOT DESTROY. PLEASE READ CAREFULLY AND KEEP IN A SAFE PLACE FOR FUTURE REFERENCE.

TABLE OF CONTENTS

<p>General 3</p> <p style="padding-left: 20px;">Unit Dimensions 3</p> <p style="padding-left: 20px;">Furnace Airflow Data 4</p> <p style="padding-left: 20px;">Clearances to Combustible Materials 4</p> <p style="padding-left: 20px;">Shipping Weights 4</p> <p>Owner's Information 5</p> <p>Installation Requirements 5</p> <p style="padding-left: 20px;">Location 6</p> <p>Circulating Air Supply 6</p> <p>Return Air Provisions 7</p> <p>Air Distribution Systems 7</p> <p>Upflow Furnace Installation 8</p> <p>Downflow Furnace Installation 8</p> <p>Venting and Combustion</p> <p style="padding-left: 20px;">Air Requirements 11</p> <p>Venting Requirements 11</p> <p style="padding-left: 20px;">Vent Table 12</p> <p style="padding-left: 20px;">Vent Pipe Material 13</p> <p style="padding-left: 20px;">Vent Pipe Length and Diameter 13</p> <p style="padding-left: 20px;">Vent Pipe Installation 14</p> <p style="padding-left: 20px;">Pipe Routing & Support 14</p> <p style="padding-left: 20px;">Horizontal Venting 17</p> <p style="padding-left: 20px;">Vertical Venting 17</p> <p style="padding-left: 20px;">Vent Freezing Protection 18</p> <p>Drainage of Condensate</p> <p style="padding-left: 20px;">From Furnace 18</p> <p>Gas Supply and Piping 19</p> <p style="padding-left: 20px;">Leak Check 20</p> <p style="padding-left: 20px;">High Altitude Derate 20</p> <p>Conversion 21</p>	<p>Lighting and Adjustment of the Appliance 23</p> <p>Electrical Wiring 24</p> <p style="padding-left: 20px;">Line Voltage Wiring 24</p> <p style="padding-left: 20px;">Low Voltage Wiring 25</p> <p>Ventilation 26</p> <p>Start-up and Adjustment 26</p> <p style="padding-left: 20px;">Start-Up Procedure 26</p> <p style="padding-left: 20px;">Shut Down Procedure 26</p> <p style="padding-left: 20px;">Verifying and Adjusting Firing Rate 26</p> <p style="padding-left: 20px;">Verifying and Adjusting Temperature Rise 27</p> <p style="padding-left: 20px;">Verifying Burner Operation 28</p> <p style="padding-left: 20px;">Verifying Operation of the Supply Air Limit Switch 28</p> <p>Description of Components 28</p> <p>Maintenance 29</p> <p style="padding-left: 20px;">Combustion Air and Vent System ... 29</p> <p style="padding-left: 20px;">Air Filter(s) 29</p> <p style="padding-left: 20px;">Lubrication 29</p> <p style="padding-left: 20px;">Condensate Drain Assembly 29</p> <p style="padding-left: 20px;">Blower Compartment 29</p> <p style="padding-left: 20px;">Heat Exchanger and Burner Maintenance 29</p> <p>System Operation Information 30</p> <p style="padding-left: 20px;">Sequence of Operation 30</p> <p style="padding-left: 20px;">Furnace Fails to Operate 31</p> <p>Furnace Accessories 31</p> <p>Location of Major Components 32</p> <p>Wiring Diagram 33</p> <p>Installation/Performance Checklist 34</p>
---	---

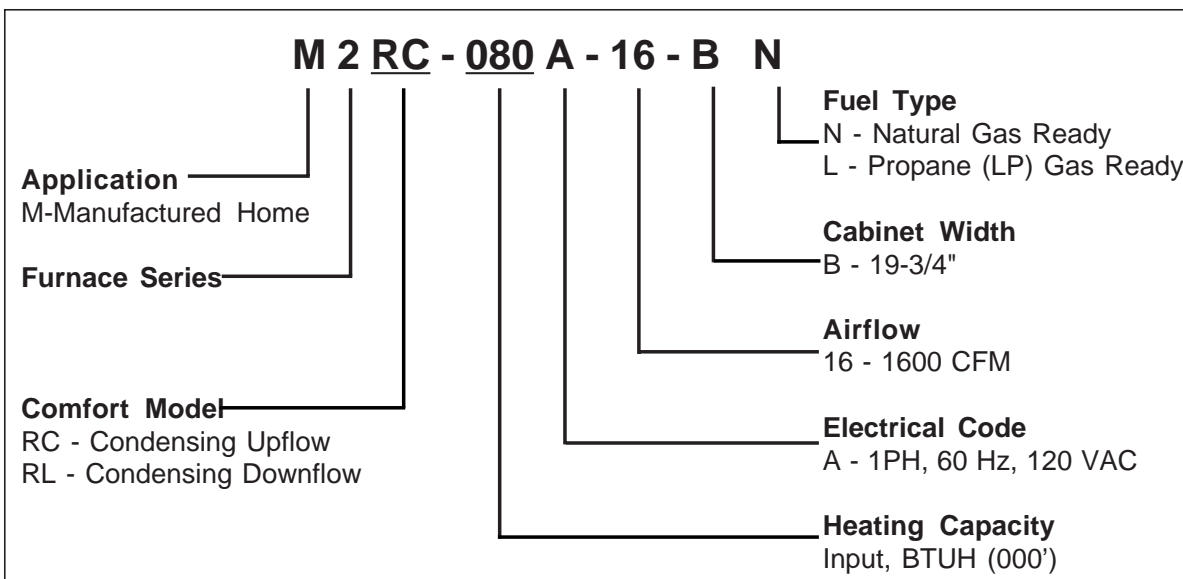
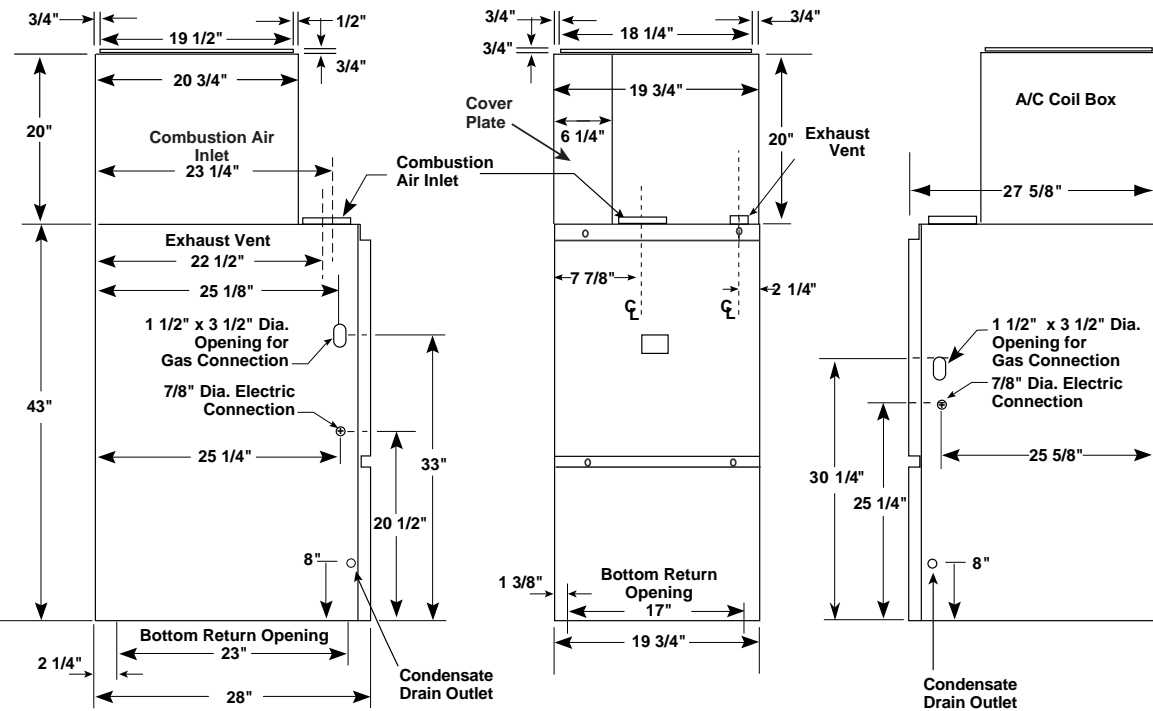

Table 1. Model Identification

GENERAL

Upflow Furnace



Downflow Furnace

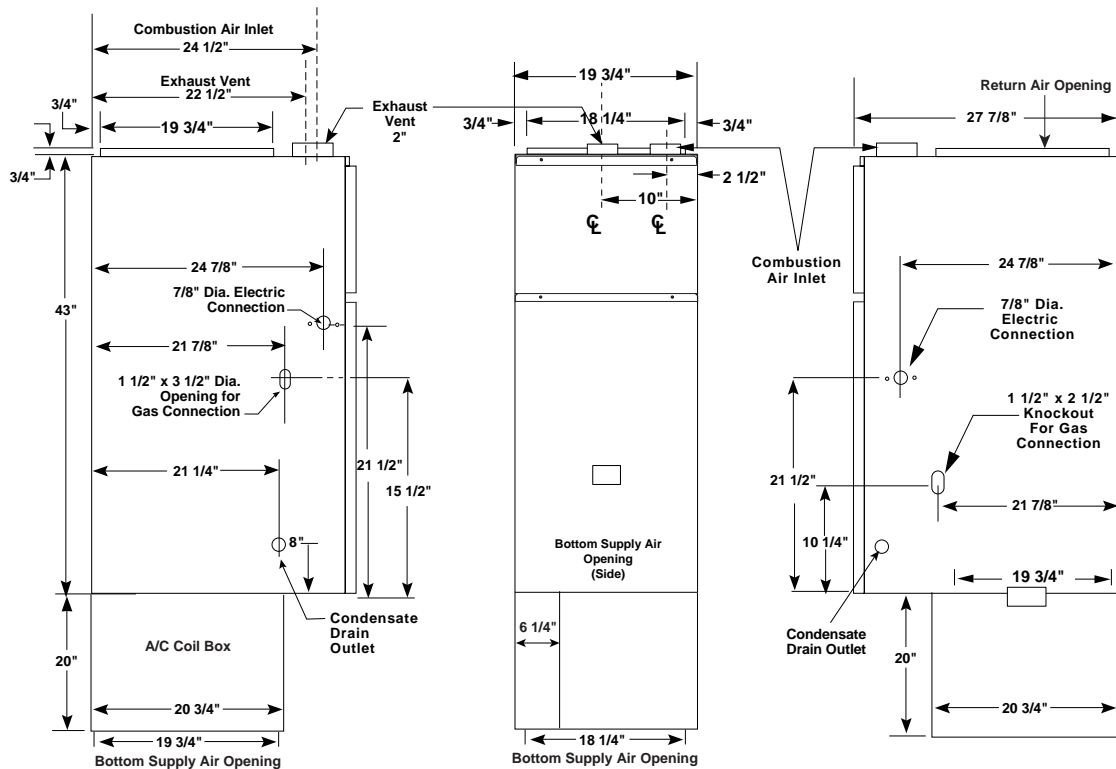

Figure 1. Unit Dimensions

IMPORTANT: READ ALL INSTRUCTIONS CAREFULLY BEFORE BEGINNING THE INSTALLATION.

! WARNING:

Do not use this product if any part has been submerged under water. Immediately call a qualified service technician to inspect the appliance and to replace any part of the control system and any gas control that has been submerged under water.

! WARNING:

Should overheating occur, or the gas fail to shut off, shut off the manual gas valve to the appliance before shutting off the electrical supply.

NOTICE: Leave these instructions with the homeowner. Advise unit owner/user to follow the maintenance recommendations outlined. Have a qual-

ified service technician periodically check all wiring connections and service unit as required.

The M2 series gas furnaces are listed direct vent (sealed combustion) forced air furnaces (type FSP) for use with both natural and propane (LP) gases. The M2 furnace series has been certified to the UL 307B standard for use in the United States and to ANSI Z21.47a-CAN/CGA-2.3a-1995 for use in the United States and Canada.

These furnaces may be installed in:

1. Manufactured Homes
2. Recreational Vehicles, Park Models
3. Manufactured Buildings
4. Modular Homes / Buildings

The M2 furnace is not to be used for the temporary heating of buildings under construction.

Model	Shipping Weight (lbs)
M2RC - 080A - 16 - B(*)	160
M2RC - 100A - 16 - B(*)	170
M2RL - 060A - 16 - B(*)	170
M2RL - 080A - 16 - B(*)	170
M2RL - 100A - 16 - B(*)	175
A/C Coil Box	20

*Can be N or L

Table 2. Shipping Weights

CAPACITIES—Furnace Airflow Data

Furnace Model No.	Furnace Input Btuh	Motor Speed	Motor HP	External Static Pressure (Inches Water Column)									
				0.1		0.2		0.3		0.4		0.5	
				CFM	Rise	CFM	Rise	CFM	Rise	CFM	Rise	CFM	Rise
M2RC-080	80,000	High *	1/2	1840	-	1780	-	1700	-	1630	-	1550	-
		Med-High		1600	43	1560	44	1470	47	1400	49	1350	51
		Med-Low **		1380	50	1350	51	1300	53	1250	55	1190	58
		Low		1100	-	1050	-	1000	-	950	-	900	-
M2RC-100	100,000	High *	1/2	1910	-	1860	-	1780	-	1700	-	1620	-
		Med-High **		1640	53	1620	54	1540	57	1480	59	1420	62
		Med-Low		1440	61	1410	62	1370	64	1320	66	1270	70
		Low		1230	-	1210	-	1180	-	1140	-	1090	-
M2RL-060	60,000	High *	1/2	1620	32	1560	33	1490	35	1430	36	1365	38
		Med High		1450	36	1400	37	1350	38	1295	40	1240	42
		Med Low **		1255	42	1225	43	1180	44	1145	45	1105	47
		Low		1080	48	1055	49	1030	51	1000	52	960	54
M2RL-080	80,000	High *	1/2	1620	43	1560	45	1490	47	1430	49	1365	52
		Med High		1450	49	1400	50	1350	52	1295	54	1240	57
		Med Low **		1255	56	1225	57	1180	60	1145	61	1105	64
		Low		1080	65	1055	67	1030	68	1000	70	960	73
M2RL-100	100,000	High *	1/2	1620	54	1555	57	1485	59	1425	62	1355	65
		Med High **		1430	62	1375	64	1330	66	1265	70	1210	73
		Med Low		1260	70	1220	72	1170	75	1130	-	1070	-
		Low		1085	-	1050	-	1015	-	970	-	935	-

* Factory wired cooling speed tap
 ** Factory wired heating speed tap

- Not Recommended

NOTE: Data is for operation with filter.

Table 3. Furnace Airflow Data

CLEARANCES TO COMBUSTIBLE MATERIALS

This furnace is designed for the minimum clearances to combustible material listed in Table 4. Refer to the furnace name plate, located inside the furnace cabinet, for specific model number and clearance information.

Furnace Input (Btuh)	Cabinet Width (Inches)	Minimum Clearances (Inches)						
		Side	Vent	Back	Top*	Front**	Plenum Surfaces	Ductwork within 3 ft. of Furnace
60,000	19 3/4	0	0	0	10	0	1/4	1/4
80,000	19 3/4	0	0	0	10	0	1/4	1/4
100,000	19 3/4	0	0	0	10	0	1/4	1/4

* For Downflow model only. Upflow models can be 1".

** 24 inches is the minimum clearance for servicing. 36 inches is the recommended clearance for service.

Table 4. Minimum Clearances to Combustible Materials

NOTICE TO INSTALLER

Installer is advised to follow carefully all instructions and warnings in this manual to insure maximum performance, safety, and operating efficiency of these appliances. Improper installation may create hazardous conditions, and will void the appliance warranty.

OWNER'S INFORMATION

About Your Central Furnace System

NORDYNE has been involved in the design of products for the manufactured home industry since the first manufactured home or trailer was built.

NORDYNE originated the sealed combustion system, which separates the furnace combustion system from the living area of the home and is now a standard for the manufactured home industry.

NORDYNE engineers developed the first central heating system and the first central air conditioner for manufactured homes.

NORDYNE is dedicated to bringing to its customers the finest heating and cooling comfort possible. NORDYNE constantly seeks to further refine its products to continuously provide exceptional comfort.

Follow the instructions in this booklet carefully and this appliance will provide many years of superior performance.

If you wish to cool your home automatically with a central air conditioning system investigate the excellent NORDYNE cooling systems available from your heating and cooling contractor. These systems are designed to work best with your NORDYNE furnace and have been carefully engineered to deliver optimal performance when mated with NORDYNE manufactured home furnaces.

NORDYNE also offers water heaters, fireplaces and ventilating systems specifically designed for manufactured housing applications. Ask your manufactured home retailer, your heating and cooling contractor, or your distributor for more information. Write directly to the factory (PO Box 46911, St. Louis, MO 63146) if you are unable to locate a source for NORDYNE manufactured housing products in your area.

Manufacturer Warranty, Owner's Responsibilities

It is the sole responsibility of the homeowner to make certain the gas furnace has been correctly installed in the home, converted to the proper fuel (LP gas or Natural gas), and adjusted for proper operation.

A warranty certificate with full details is included with this furnace. However, NORDYNE will not be responsible for any costs found necessary to correct problems due to improper setup, improper installation, furnace adjustments, improper operating procedure on the part of the user, etc.

Some specific examples of service calls which cannot be included in warranty payments are:

1. Converting the furnace to use another type of gas.
2. Repairing duct work in the home found to be faulty.
3. Correcting wiring problems in the electrical circuit supplying the furnace.
4. Resetting circuit breakers, blown fuses or other switches.
5. Correcting problems due to improper gas supply pressure to the furnace.
6. Providing instructional training on how to light and operate the furnace.
7. Correcting any problems caused by installation of an air conditioner, heat pump or other air comfort devices.
8. Revising installation of the furnace flue assembly.
9. Adjusting or calibrating of thermostat.
10. Removing any construction debris which has fallen into flue system.

Carefully review these responsibilities with your manufactured housing dealer, service company, or gas supplier, so that there will be no misunderstanding at a later time.

INSTALLATION REQUIREMENTS

Requirements and Codes:

The installer must be familiar with and comply with all local codes and regulations applicable to the installation of heating appliances and related equipment. In the absence of local codes, the installation must conform with these instructions and the current provisions of one or more of the following standards:

- a. Federal Manufactured Home Constructions & Safety Standard (H.U.D. Title 24, Part 3280.707[a][2])

- b. The Standard for Manufactured Home Installations (Manufactured Home Sites, Communities, and Set-Ups) ANSI A225.1 and/or CAN/CSA-2240 MH Series).
- c. American National Standard (ANSI-119.2/NFPA-501C) for all recreational vehicle installations.
- d. American National Standard (ANSI-Z223.1/NFPA-54) and/or CAN/CGA B149 for all gas-fired furnace models.
- e. American National Standard (ANSI-C1/NFPA-70) and/or CSA 22.1 Canadian Electric Code Part 1 for all electrical field wiring.

CE générateur d'air chaud doit être installé conformément aux instructions du fabricant et aux codes locaux. En l'absence de code local, respecter la norme ANSI Z223.1, intitulé National Fuel Gas Code ou les codes d'installation CAN/GCA-B149.

The National Fuel Gas Code is available by writing:

American National Standards Institute, Inc.
1430 Broadway
New York, NY 10018

NFPA publications are available by writing:

National Fire Protection Association
Batterymarch Park
Quincy, ME 02269

Location

The furnace must be installed on a level surface, and as close to the center of the air distribution system as possible. See Figure 1 for overall dimensions to determine the required clearances in hallways, doorways, stairs, etc. to allow the furnace to be moved to the installation point. The furnace must be installed so that all electrical components are protected from water.

Minimum clearances to combustible materials are listed in Table 4. Access for positioning and servicing must be considered when locating the unit. 24 inches is the minimum required clearance for servicing the unit. 30 inches is the minimum required clearance for positioning the unit. **36 inches is the recommended clearance from the front of the unit.** Please note that a panel or door can be located such that the minimum clearance on the rating plate is satisfied, but that panel or door must be remov-

able and allow the appropriate clearance for your installation.

This furnace is certified for use on wood flooring. The furnace must be installed on a solid surface and must be level front to back and side to side. This furnace must not be installed directly on carpeting, tile, or any combustible material other than wood flooring. Downflow models can only be installed on combustible flooring when installed on a Nordyne plenum base (part numbers 901987 through 901993 - see Table 5). Both the upflow and downflow models must be installed with the Nordyne A/C coil box (part no. 914958).

The plenum attached to the A/C coil box and the ductwork within 3 feet of the furnace must be installed such that surfaces are at least 1/4" from combustible construction.

CIRCULATING AIR SUPPLY

General

Plenums and air ducts must be installed in accordance with the Standard for the Installation of Air Conditioning and Ventilating Systems (NFPA No. 90A) or the Standard for the Installation of Warm Air Heating and Air Conditioning Systems (NFPA No. 90B).

WARNING:

Products of combustion must not be allowed to enter the return air openings of the furnace or the circulating air supply. Failure to prevent products of combustion from being circulated into the living space can create potentially hazardous conditions including carbon monoxide poisoning that could result in personal injury or death.

The floor or platform on which the furnace is mounted must provide sound physical support of the furnace with no gaps, cracks, or sagging between the furnace and the floor or platform.

The circulating air ductwork must not be connected to any other heat producing device such as a fireplace insert, stove, etc.

RETURN AIR PROVISIONS

Upflow models draw the return air from the base of the furnace. A stand or return air duct must be supplied to the furnace to provide the required return air.

Downflow models draw the return air from the top of the furnace. The minimum required clearance to the top of the furnace is detailed on the furnace rating plate. Additional clearance may be required depending upon filter accessibility.

For each application, the U.S.A. home manufacturer shall comply with all of the following conditions to have acceptable return air systems for closet installed forced air heating appliances:

- a. Regardless of the location, the return air opening into the closet shall not be less than specified in the appliance's listing.
- b. Means shall be provided to prevent inadvertent closure by a flat object placed over the return air opening when it is located in the floor of the closet (versus the vertical front or side wall).
- c. The cross-sectional area of the return duct system leading into the closet shall not be less than 390 square inches.
- d. The total free area of openings in the floor or ceiling registers serving the return air duct system must be at least 352 sq. in. At least one register should be located where it is not likely to be covered by carpeting, boxes and other objects.
- e. Materials located in the return duct system must have a flame spread classification of 200 or less. This includes a closet door if the furnace is in a closet.
- f. Noncombustible pans having 1" upturned flanges are located beneath openings in a floor duct system.
- g. Wiring materials located in the return duct system shall conform to Articles 300-22 of the National Electrical Code (ANSI C1/NFPA-70).
- h. Gas piping is not run in or through the return duct system.
- i. Test the negative pressure in the closet with the air-circulating fan operating at high speed and the closet closed. The negative pressure is to be no more negative than minus 0.05 inch water column.

- j. For floor return systems, the manufactured home manufacturer shall affix a prominent marking on or near the appliance where it can be easily read when the closet door is open. The marking shall read:

CAUTION:

HAZARD OF ASPHYXIATION: Do not cover or restrict return air opening.

- k. Air conditioning systems may require more duct, register and open louver area to obtain necessary airflow. Use NORDYNE's certiduct program to determine proper duct size for A/C.

AIR DISTRIBUTION SYSTEMS

For proper air distribution, the supply duct system must be designed so that the static pressure measured external to the furnace does not exceed the listed static pressure rating shown on the furnace rating plate.

Three typical distribution systems are illustrated in Figure 2. Location, size, and number of registers should be selected on the basis of best air distribution and floor plan of the home.

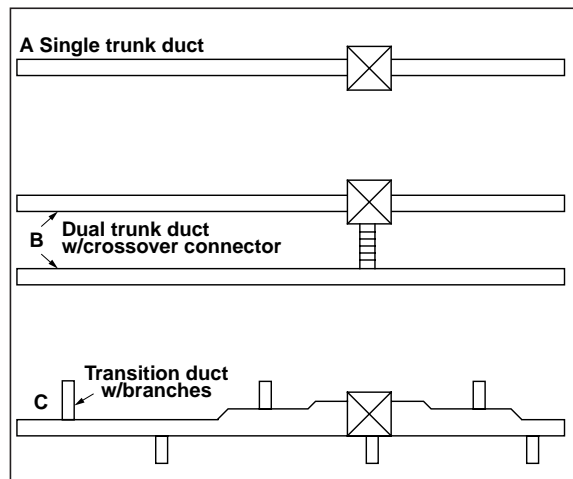

Figure 2. Typical Supply Duct System

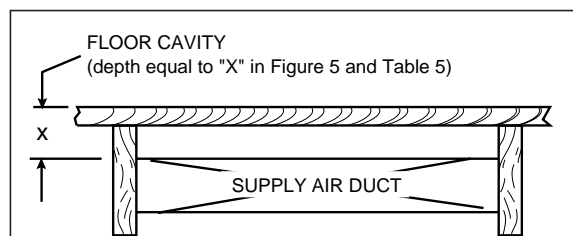

Figure 3. Floor Cavity Cut-Out

If "X" (Floor cavity) is:	Use Duct Connector Model
7/8" (22mm)	901987
2" (51mm)	901988
4 1/4" (108mm)	901989
6 1/4" (159mm)	901990
8 1/4" (210mm)	901991
10 1/4" (260mm)	901992
12 1/4" (311mm)	901993

Table 5. Duct Connectors

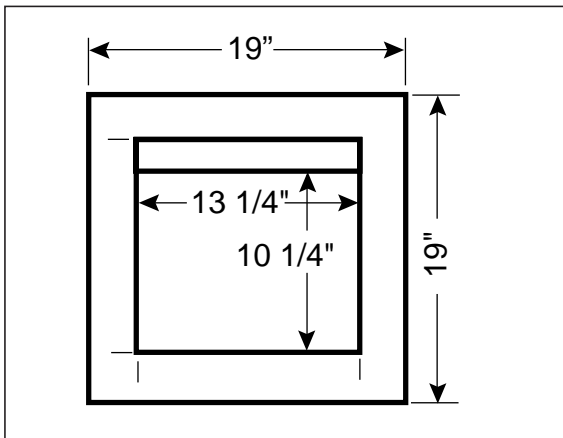

Figure 4. Top View of Duct Connector

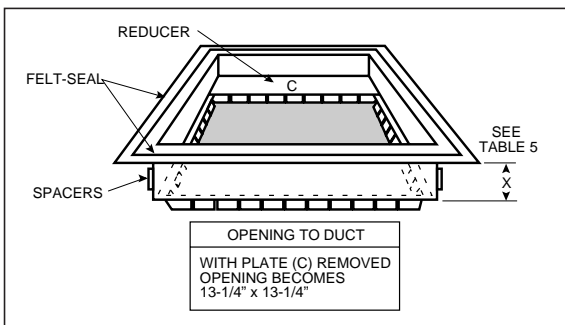

Figure 5. Duct Connector

UPFLOW FURNACE INSTALLATION

- Position the furnace on top of the return air ductwork or return air stand. **NOTE:** The ductwork or stand must have an opening equal to that of the return air opening of the furnace. Refer to Figure 1 for the proper return air opening size. Secure the furnace to the floor or base once it has been properly positioned.
- Position and secure the A/C coil box to the top of the furnace. The A/C coil box

can be secured to the furnace using the provided attachment brackets. These brackets are designed to attach the furnace cabinet to the A/C coil box on the sides. To install these brackets, position one bracket on the side of the furnace, so that the locating dimples are in the groove created by the top of the furnace cabinet and the bottom of the A/C coil box. Using the provided self-drilling screws, secure the bracket to the A/C coil box and the furnace. Repeat on the other side of the furnace for the other bracket.

- Attach the plenum from the supply duct to the flanges of the A/C coil box.
- Secure the plenum to the supply ductwork.

NOTE: Additional fasteners may be used at rear, sides or through door frame, as desired, to secure furnace to closet or alcove framing.

DOWNFLOW FURNACE INSTALLATION

DUCT CONNECTOR SELECTION FOR DOWNFLOW MODELS

- Determine depth of floor cavity from surface of floor to top of supply air duct (See Figure 3).
- Select appropriate model from Table 5 which matches X-dimension of the floor cavity. To maximize air delivery, remove reducer "C" (see Figure 5) to obtain the largest open area that will fit the duct/floor construction.

INSTALLATION OF THE DUCT CONNEC- TOR FOR DOWNFLOW INSTALLATIONS

Required cut-out openings in the floor, ceiling, roof, and/or walls must be carefully located to avoid misalignment of the furnace, combustion air piping, and vent piping (see Figures 14-16). Installation procedures are suggested for typical furnace installations and need not be followed in the exact listed sequence.

CUT OUT FLOOR OPENING FOR DOWNFLOW MODELS

- Determine center of closet or alcove (Figure 7).
- Locate center of the floor opening, measured 10" from the rear wall, and mark cut-out measuring approximately 14-1/2" by 14-1/2" ($\pm 1"$) for model duct connector used (refer to Figures 6 & 7).

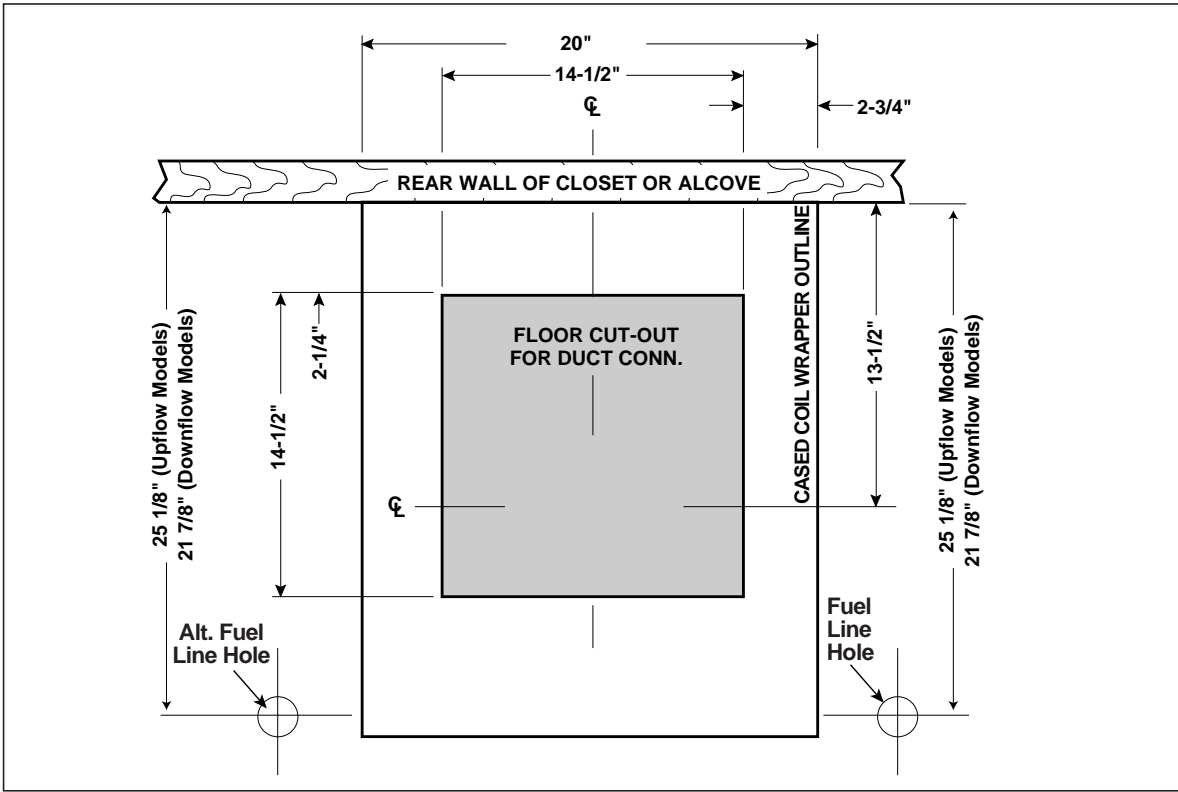

Figure 6. Cut-Out Locations

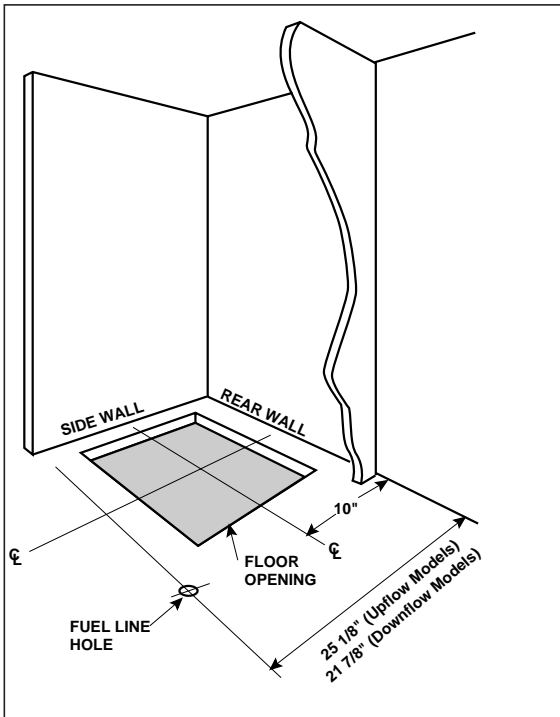

Figure 7. Closet or Alcove Floor Cut-Out

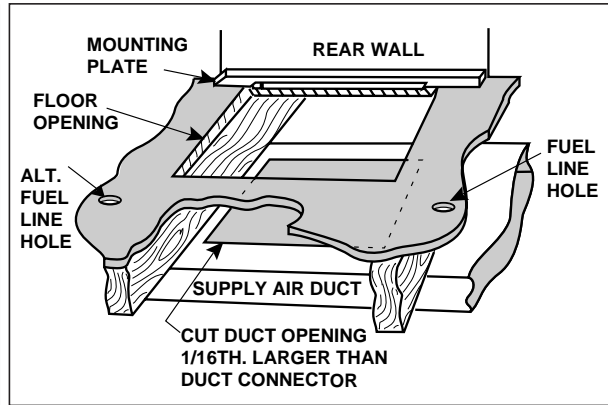

Figure 8. Mounting Plate

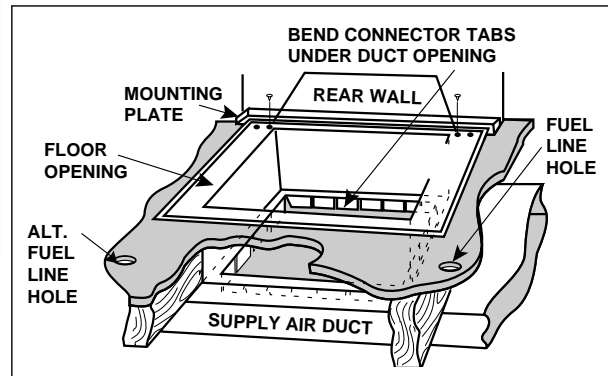

Figure 9. Duct Connector

CUT DUCT OPENING

- a. Place duct connector through the floor opening with bottom tabs resting on top of the supply air duct.
- b. Center duct connector and push back against rear edge of floor opening.
- c. Mark cut-out location (tab area) and remove duct connector.
- d. Cut out duct opening 1/4" larger than area marked.

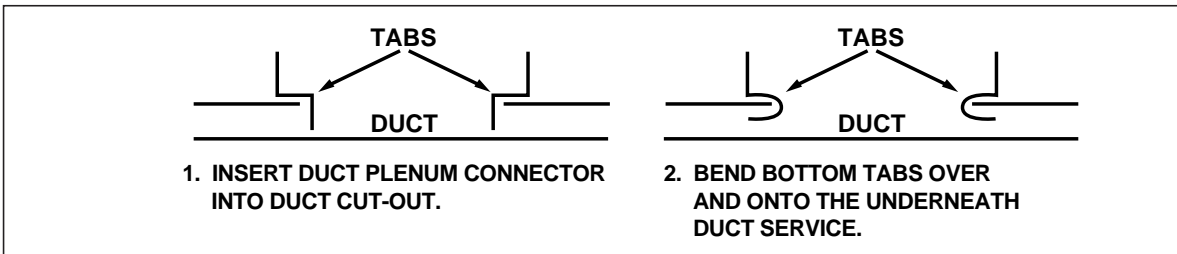

Figure 10. Installation of Duct Connector

INSTALL FURNACE MOUNTING PLATE

- a. Bend tabs on furnace mounting plate upwards 90°
- b. Place mounting plate (supplied within duct connector) at rear of the floor opening (See Figure 8).

INSTALL DUCT CONNECTOR

- a. Place duct connector through the floor opening with bottom tabs extending through the duct opening. (See Figure 9)
- b. Secure duct connector to floor.
- c. Bend bottom tabs under and up tightly against the supply air duct (See Figure 10).

NOTE: The duct connector is designed for use on ducts 12" in width. When using the connector on 12" wide ducts, there may be insufficient clearance to bend the tabs on two sides of the duct connector. In such cases the tabs may be attached to the sides of the duct by using sheet metal screws or other suitable fasteners. (See Figure 11).

If tape is used to provide a better seal, it should be approved by applicable national or local codes.

ALTERNATE ATTACHMENT METHODS

This procedure may also be used to install a furnace duct connector to narrow metal ductwork where insufficient clearance prevents bending of the duct connector tabs at the side(s) of the duct. (See Figure 12).

1. Score and cut the top of the metal duct as indicated in Step 1 or Step 2. With Step 1 choice, also cut out the metal from the shaded area "A".
2. Fold the duct flap "B" up, (See Step 3).
3. At the front-to-back of duct run (Area "A"), bend the duct tabs and secure them directly to the duct.

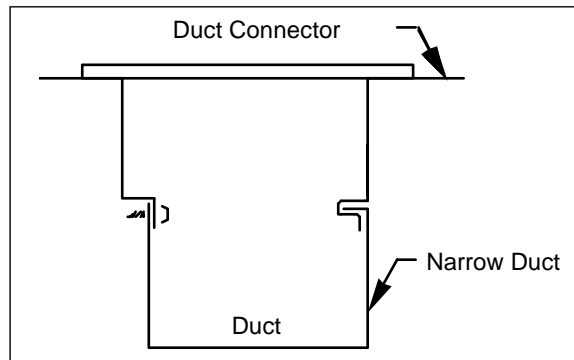

Figure 11. Narrow Duct Installation

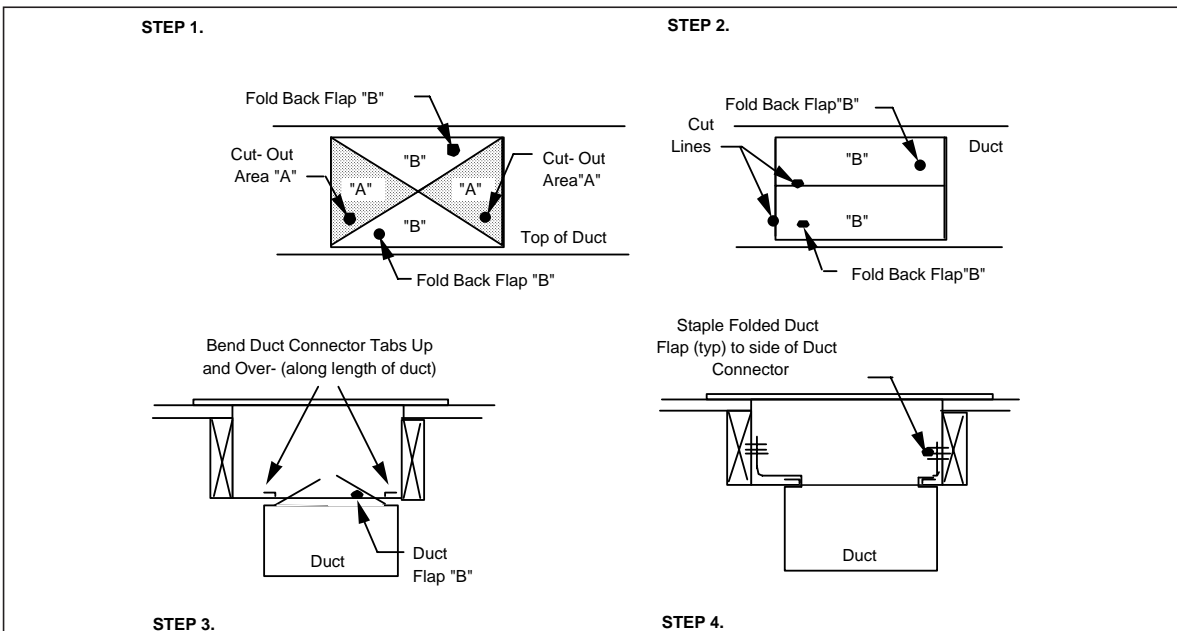

Figure 12. Alternate Installation

4. At area "B", bend the duct tabs up and back over, around the duct connector, (See Step 3).
5. Fold/form the duct flap against the side of the duct connector and attach as shown, (See Step 4). Use three (3) staples (minimum) on each duct flap OR, if a 2X block/joist is not provided, use two (2) sheet metal screws (minimum) on each duct flap. An alternate attachment method is acceptable, as long as the plenum is securely attached.
6. Tape the duct flap edges with an approved tape for a leak-free joint.

INSTALL DOWNFLOW FURNACE

- a. Prepare the A/C coil box as described in the instructions provided with the coil box.
- b. Place A/C coil box onto duct connector.
- c. Slide A/C coil box back until it is firmly against the mounting plate. Mounting plate tabs should be bent upwards so as not to interfere with furnace.
- d. Secure front with one (1) fastener at each corner through front bottom flange and through the back of the A/C coil box.
- e. Position the furnace on top of the A/C coil box. Ensure that the furnace is properly positioned on the wrapper.
- f. Secure the A/C coil box to the bottom of the furnace. The A/C coil box can be secured to the furnace using the provided attachment brackets. These brackets are designed to attach the furnace cabinet to the A/C coil box on the sides. To install these brackets, position one bracket on the side of the furnace, so that the locating dimples are in the groove created by the bottom of the furnace cabinet and the top of the A/C coil box. Using the provided self-drilling screws, secure the bracket to the A/C coil box and to the furnace. Repeat on the other side of the furnace for the other bracket.

NOTE: Additional fasteners may be used at rear, sides or through door frame, as desired, to secure furnace to closet or alcove framing.

VENTING AND COMBUSTION AIR REQUIREMENTS

CAUTION:

Snow must not be allowed to restrict or block the combustion air intake or vent pipes.

General

NORDYNE condensing furnaces must be installed with outdoor combustion air piped directly to the furnace. Codes refer to this type of installation as direct vent, or two pipe installation.

Provisions must be made for adequate supply of air for combustion and ventilation. For United States installations, the adequacy of air provisions can be determined by consulting the current version of the National Fuel Gas Code (ANSI Z223.1/NPFA-54). For Canadian installations, requirements are specified in the National Standard of Canada (CAN/CGA B149.1 & .2). Consult local codes for special requirements.

NOTE: If the furnace is operated without adequate air for combustion and ventilation, it may not perform properly. Furnace components may be strained by high temperature and could fail prematurely.

WARNING:

The combustion air piping must not be blocked or restricted in any manner.

WARNING:

Furnace installation using methods other than those described in the following sections must comply with the National Fuel Gas Code and all applicable local codes to provide sufficient combustion air for the furnace.

VENTING REQUIREMENTS

WARNING:

FURNACE MUST NOT BE COMMON VENTED WITH OTHER APPLIANCES.

General

This section specifies installation requirements for 2-pipe combustion air piping. The capacity table provided in this section applies to the total sum of vent and combustion air piping lengths.

These condensing furnaces are classified as "Category IV" appliances, which require special venting materials and installation procedures. Category IV appliances operate with positive vent pressure and therefore require vent systems which are thoroughly sealed. They also produce combustion condensate, which is slightly acidic and can cause severe corrosion of ordinary venting materials. Furnace operation can be adversely affected by restrictive vent and combustion air piping. Therefore, *vent and combustion air piping lengths must conform completely to the requirements of Table 6.*

The furnace must be vented to the outdoors. It must not be vented in common with any other appliance, even if that appliance is of the condensing type. Common venting can result in severe corrosion of other appliances or their venting and can allow combustion gases to escape through such appliances or vents. Do not vent the furnace to a fireplace chimney or building chase.

If removing an existing furnace in a venting system, the venting system may not be properly sized. To test the vent system with the remaining appliances, follow the test outlined below.

The following steps shall be followed with each appliance connected to the venting system place in operation, while any other appliances connected to the venting system are not in operation:

- a. Seal any unused openings in the venting system.

- b. Inspect the venting system for proper size and horizontal pitch, as required in the National Fuel Gas Code, ANSI Z223.1 or the CAN/CGA B149 Installation Codes and these instructions. Determine that there is no blockage or restriction, leakage, corrosion and other deficiencies which could cause an unsafe condition.
- c. In so far as is practical, close all building doors and windows and all doors between the space in which the appliance(s) connected to the venting system are located and other spaces of the building. Turn on clothes dryers and any other appliance not connected to the venting system. Turn on any exhaust fans, such as range hoods and bathroom exhausts, so they shall operate at maximum speed. Do not operate a summer exhaust fan. Close fireplace dampers.
- d. Follow the lighting instructions. Place the appliance being inspected in operation. Adjust thermostat so appliance shall operate continuously.
- e. Test for draft hood equipped appliance spillage at the draft hood relief opening after 5 minutes of main burner operation. Use the flame of a match or candle.
- f. After it has been determined that each appliance connected to the venting system properly vents when tested as outlined above, return doors, windows, exhaust fans, fireplace dampers and any other gas burning appliance to their previous conditions of use.

APPLICATION	DIRECT VENT, DUAL PIPE LENGTH (ft.) with 1 long radius elbow on each pipe.*	
	Inlet/Outlet	
PVC, CPVC or ABS SCH. 40 Pipe Size	3"	3"
Model M2RL 060	50	50
Model M2RC/L 080	90	90
Model M2RC/L 100	90	90

***NOTES**

1. Subtract 3.5 ft. for each additional 3" elbow.
2. Two 45 degree elbows are equivalent to one 90 degree elbow.
3. One short radius elbow is equivalent to two long radius elbows.
4. Do not include termination elbows in calculation of vent length.
5. This table is applicable for elevations from sea level to 2000 ft. For higher elevations, decrease vent pipe lengths by 8% per 1000 ft. of altitude.
6. Only the above pipe materials are approved for use with these condensing furnaces.

Table 6. Vent Table

- g. If improper venting is observed during any of the above tests, the venting system must be corrected.

Procéder comme suit pour chaque appareil raccordé à la tuyauterie d'évacuation et en état normal de fonctionnement; tous les autres appareils raccordés à la même tuyauterie d'évacuation doivent être mis hors service:

- a. sceller toute ouverture non utilisée de la tuyauterie d'évacuation
- b. s'assurer que la tuyauterie d'évacuation présente des dimensions et une pente horizontale conformes à la norme ANSI Z223.1, intitulée National Fuel Gas Code ou aux codes d'installation CAN/CGA B149, ainsi qu'aux présentes instructions. S'assurer que la tuyauterie n'est pas bloquée, restreinte, corrodée, qu'elle ne fuit pas et qu'elle ne présente aucun autre défaut potentiellement dangereux.
- c. dans la mesure du possible, fermer toutes les portes et fenêtres du bâtiment, et toutes les portes entre la pièce où se trouve l'appareil raccordé à la tuyauterie d'évacuation et les autres pièces du bâtiment. Mettre en service les sècheuses et tout autre appareil qui n'est pas raccordé à la tuyauterie d'évacuation. Faire fonctionner à régime maximal tout ventilateur d'évacuation, tel que les hottes de cuisinière et les ventilateurs de salles de bains. Ne pas mettre en service les ventilateurs d'été. Fermer les registres des foyers.
- d. respecter les instructions d'allumage. Mettre en service l'appareil à l'essai. Régler le thermostat de manière à ce que l'appareil fonctionne sans interruption
- e. S'assurer qu'un appareil muni d'un coupe-tirage ne présente aucune fuite à l'ouverture du coupe-tirage après que le brûleur principal ait fonctionné pendant cinq minutes. Employer la flamme d'une allumette ou d'une chandelle.
- f. Après avoir déterminé que tous les appareils raccordés à la tuyauterie d'évacuation évacuent correctement tel que prescrit ci-dessus, rouvrir les portes et les fenêtres et remettre les ventilateurs d'évacuation, les registres de foyers et tout autre appareil fonctionnant au gaz à leur état de fonctionnement initial.
- g. Si un appareil n'évacue pas correctement à la suite de l'un des essais ci-dessus, corriger la tuyauterie d'évacuation.

Vent Pipe Material

Vent and combustion air pipe and fittings must be one of the following materials and must conform to the indicated ANSI/ASTM standards:

Material	Standard
Schedule 40 PVC	D1785
PVC-DWV	D2665
SDR-21	D2241
& SDR-26	
ABS-DWV	D2661
Schedule 40 ABS	F628
Foam/Cellular Core PVC	F891

Cement and primer must conform to ATSM Standard D2564 for PVC and Standard D2235 for ABS. When joining PVC piping to ABS, use an appropriate solvent cement and procedure per the piping manufacturer's recommendation and ASTM Standard D3138.

Vent Pipe Length and Diameter

In order for the furnace to operate properly, the combustion air and vent piping must not be excessively restrictive. To ensure this use Table 6, which indicates the maximum allowable piping length for a furnace of specified input rate, when installed with piping of selected diameter and number of elbows. **This table applies to the length and number of elbows for each pipe.** To use the table, the furnace input rate, the centerline length and the number of elbows on each pipe must be known. Choose the diameter for which the tabulated length is equal to or greater than required.

Use of the table is illustrated in the following examples:

Example:

An 80,000 Btuh furnace is to be installed in a "two-pipe" system with 40 feet of vent piping. There are four elbows, excluding those exterior to the building.

Solution:

Consulting Table 6, in the dual pipe length column for an 80,000 Btuh furnace, the maximum allowable length for a 3" inlet/3" outlet is 90 feet with one elbow. Select 3" pipe. For two additional elbows, deduct 3.5 ft. for each elbow, or 7.0 ft. for a maximum installed vent length of 83 ft.

Condensing furnace combustion products have very little buoyancy, so Table 6 is to be used without consideration of any vertical rise in the piping.

NOTE: Always use the same or larger size piping for combustion air as is used for the exhaust vent.

Vent Pipe Installation

Pipe Routing and Support

Route piping as directly as possible between the furnace and the outdoors and remember that routing affects pipe size requirements per the preceding section. Locate the combustion air intake and the vent exhaust in the same atmospheric pressure zone - i.e. both must exit the building through the same portion of exterior wall or roof. Vent piping must be sloped upwards not less than 1/4" per foot in the direction from the furnace to the terminal. This is to ensure that any condensate flows back to the furnace (where it can be disposed of through the condensate disposal system).

! CAUTION:

Combustion air must not be drawn from a corrosive atmosphere.

The quality of outdoor air must also be considered. Be sure that the combustion air intake is not located near a source of solvent fumes or other chemicals which can cause corrosion of the furnace combustion system.

Piping must be mechanically supported so that its weight does not bear on the furnace. Supports must be at intervals no greater than five feet, and at smaller intervals if necessary to ensure

that there are no sagging sections to trap water (See Figures 14 & 15).

Figure 16 illustrates vent and combustion air pipe sizes exiting the furnace. Transition to the correct pipe size must be done close to the furnace so that the full length of pipe is of proper size.

These condensing furnaces have been certified for installation with zero clearance between vent piping and combustible surfaces. However, it is good practice to allow space for convenience in installation and service.

Pipe Couplings at the Furnace

The provided rubber couplings should be installed in the combustion air (use 3" diameter coupling) and vent (2" diameter) pipes to allow for servicing. These couplings are designed to fit snugly over the pipe and be secured to the pipes using the provided hose clamps. Use 3" x 2" flexible coupling at furnace on 2" vent pipe and on upflow units use 3" diameter coupling above coil box, as shown in Figures 14 and 15. Refer to figures 14 and 15 for the proper installation of these couplings.

Location of Outdoor Terminations

Vent and combustion air intake terminations must be located to ensure proper furnace operation and to conform to applicable codes. Figure 13 illustrates necessary distances from the vent termination to windows and building air intakes. **In Canada, the Canadian Fuel Gas Code takes precedence over these**

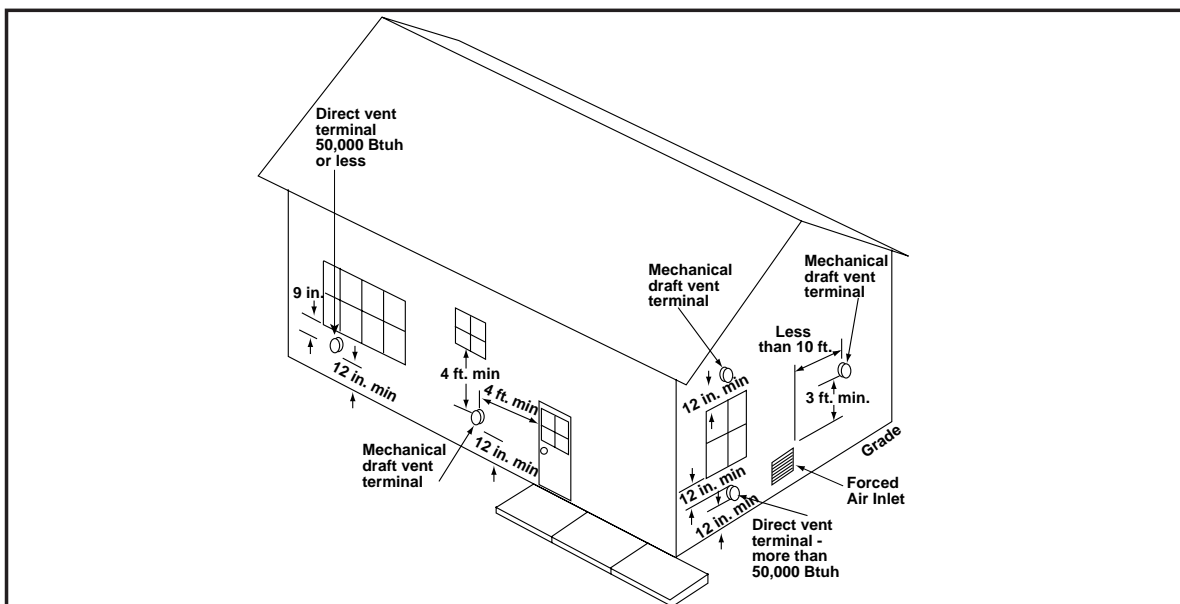

Figure 13. Vent Termination Clearances

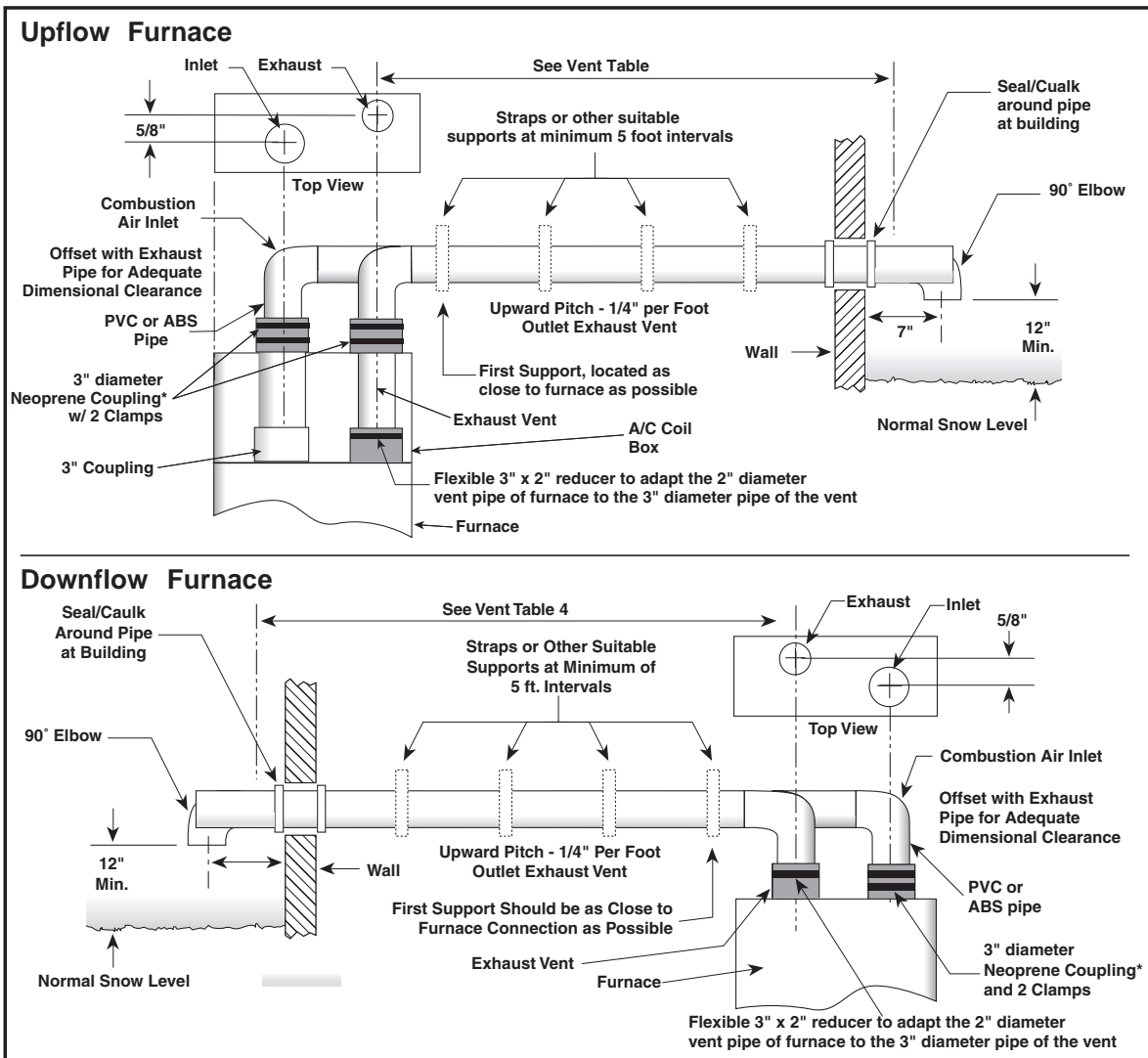

Figure 14. Horizontal Venting

* These neoprene couplings are field-supplied and can be used if the installation requires breakable connections in the piping. Note that a maximum of two couplings per pipe are allowed.

instructions. Specifically, all minimum distance requirements with respect to termination of the vent piping listed below.

The following list is a summary of vent terminal location requirements:

1. The termination must be 12 inches above snow level or grade level whichever is higher. See Figure 17 for alternate method to achieve 12" above snow level.
2. The minimum distance for a direct vent (2-pipe) installation) from any door, (openable) window, or air gravity inlet is 1 ft. below, 1 ft. horizontally, or 1 ft. above.
3. The vent termination shall be a minimum of 3 ft. above any forced air inlet within 10 ft.
4. The vent termination shall be located at least 4 ft. horizontally from any electric

- meter, gas meter, regulator and any relief equipment. These distances apply **ONLY** to U.S. installations. In Canada, the Canadian Fuel Gas Code takes precedence.
5. Avoid areas where condensate drainage may cause problems by dropping on planters or patios, etc. Also ensure that exhaust gases will not impinge on windows or building surfaces, which may be compromised or damaged by condensation. Do not install the vent terminal such that exhaust is directed into window wells, stairwells, under decks or into alcoves or similar recessed areas, and do not terminate above any public walkways.
6. Select the point of wall penetration where the minimum 1/4 inch per foot of slope up can be maintained.

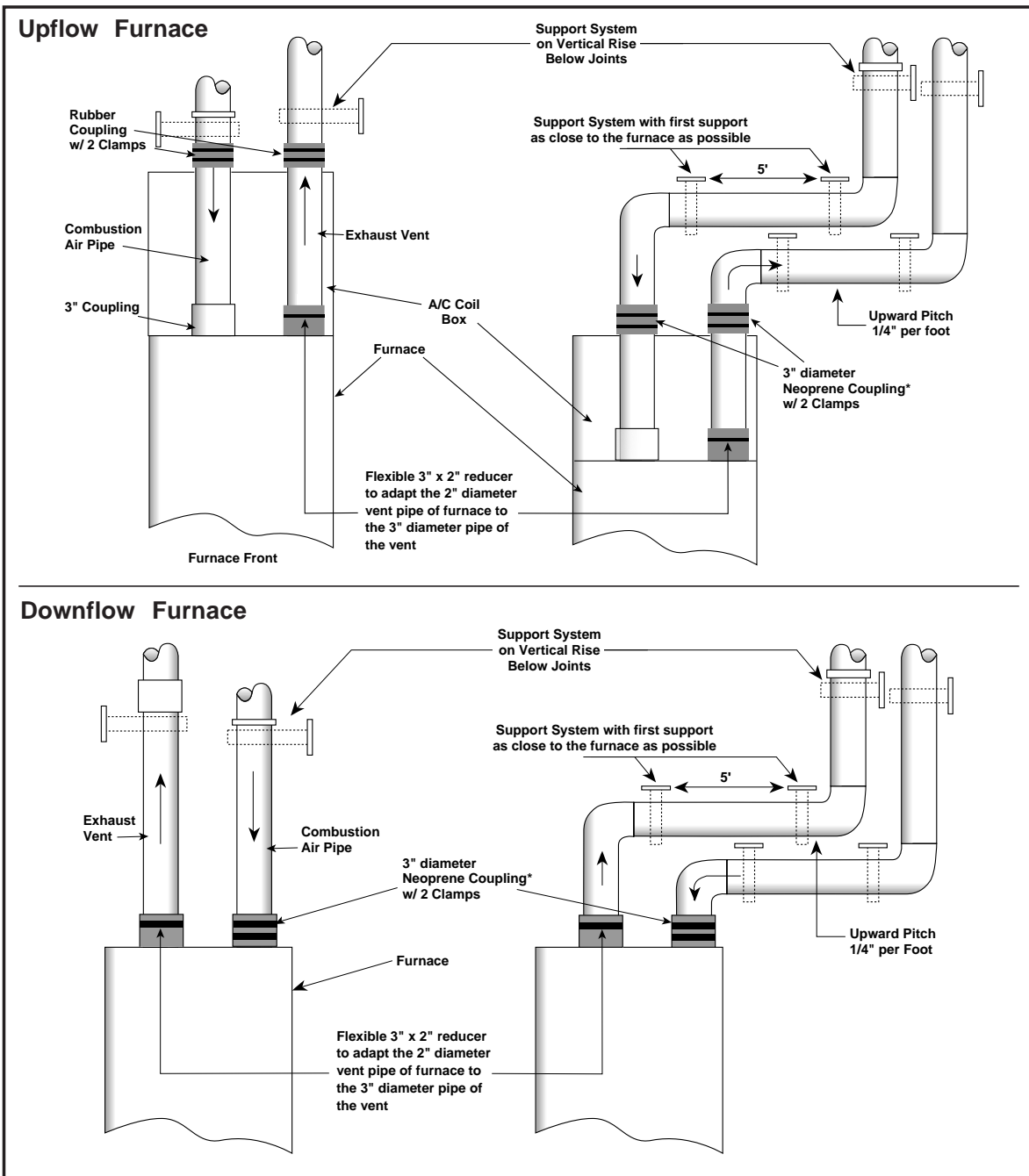

Figure 15. Vertical Venting

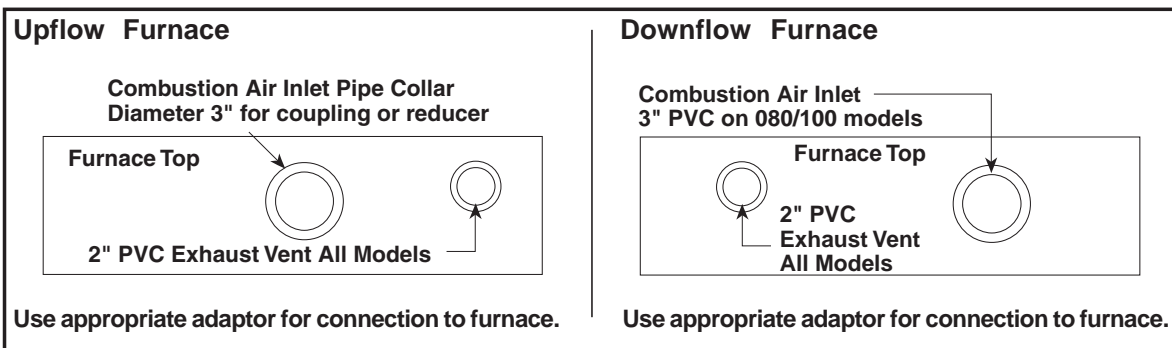

Figure 16. Furnace Pipe Adaptions

! CAUTION:

For optimal performance vent furnace through wall which experiences the least exposure to winter winds.

Horizontal Venting

Vent and combustion air intake terminations must be as shown in Figure 18.

! WARNING:

Ensure that the combustion air vent and the exhaust vent are configured as shown in Fig. 18. Improper vent termination can cause recirculation of the flue gases. This may result in furnace vibration. In severe cases, the furnace will cycle, due to the intermittent contact between the flame and the flame sensor. If you note these oscillations occurring, check the vent configuration. Make sure that the exhaust vent does not have a 90 degree termination.

For horizontal venting, one of the following kits is recommended:

3" PVC Horizontal Exterior Vent Mounting Kit	9023750
---	---------

For Canadian installations please refer to the Canadian Installation Code (CAN/CGA-B149.1 or 2) and/or local codes.

The kit consists of two face plates and an insulating gasket to seal the exterior surface. A hole sized closely to the pipe diameter must first be cut through the wall. A short length of

pipe is then cut such that it can penetrate the wall and be held in place by closely fitting standard couplings. The face plates are retained on both sides of the wall by the couplings, and the gasket is retained against the wall by the outer face plate. Face plates must be fastened to the wall and the outside one must be flashed as appropriate to prevent entry of water.

When the above kits are not used the following steps are required:

1. Check the hole size cut through the exterior wall. Insure that the hole diameter is less than the diameter of the couplings to be used.
2. Extend the vent pipe through the wall approximately 1" and seal the area between the wall and pipe.
3. Apply couplings to the vent pipe on the interior and exterior sides of the wall to insure the pipe can not be pushed or pulled through the wall.
4. Insure the combustion air inlet pipe has a 90 degree termination elbow, and is pointing downward as shown in Figures 18 & 19.

Note that a combustion air intake must be provided with an elbow opening downward.

When the vent pipe must exit an exterior wall close to the grade or expected snow level, a riser should be provided as shown in Figure 17. Insulation is required to prevent freezing of this section of pipe.

Table 7 describes the maximum length of flue pipe that can travel through an unconditioned space or an exterior space. The total vent length must not exceed the lengths noted on Table 6.

Vertical Venting

Figure 19 shows the proper installation and clearances for vertical vent termination. The

Winter Design Temperature (°F)	Maximum Flue Pipe Length in Unconditioned and Exterior Spaces	
	Without Insulation (feet)	With Insulation (feet) ‡
20	45	70
0	20	70
-20	10	60

‡ = Insulation thickness greater than 3/8 inch, based on an R value of 3.5 (ft*°F*hr)/(BTU*in)

Table 7. Vent Protection

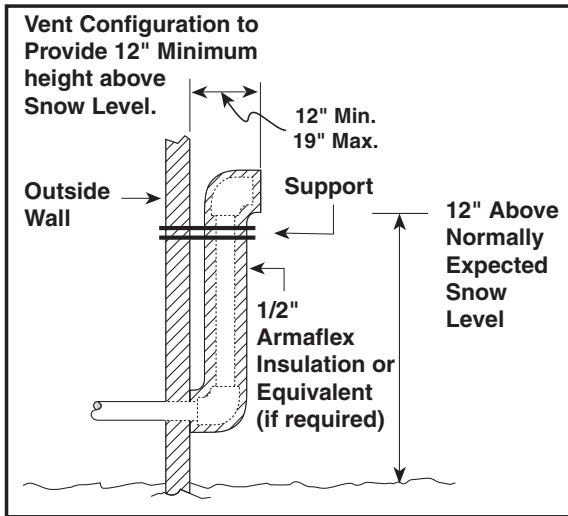

Figure 17. Alternate Horizontal Vent Installation

roof penetration must be properly flashed and waterproofed with a plumbing roof boot or equivalent flashing. Termination spacing requirements from the roof and from each other must be per Figure 19.

Vent and combustion air piping may be installed in an existing chimney which is not in use provided that:

- Both the exhaust vent and air intake run the length of the chimney.
- The top of the chimney is sealed and weatherproofed.
- The termination clearances shown in Figure 19 are maintained.
- No other gas fired appliances are vented through the chimney.

Vent Freezing Protection

To prevent condensate icing over extended runs of vent pipe exposed to temperatures

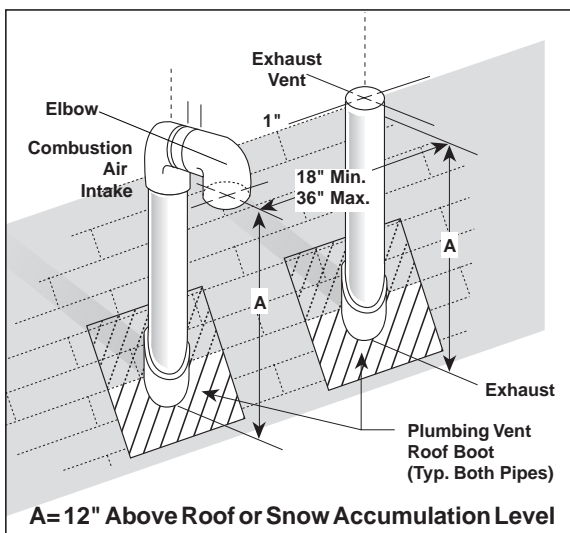

Figure 19. Vertical Vent Termination

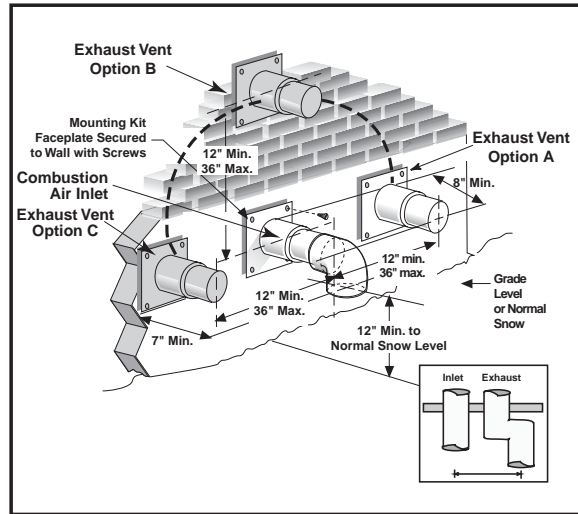

Figure 18. Exhaust and Combustion Air Pipe Clearances

below freezing, i.e., installation within a pre-existing masonry chimney; the pipe must be insulated with 1/2 inch thick sponge rubber insulation, such as an Armaflex-type or equivalent.

For extremely cold climates or for conditions of short furnace cycles (i.e. set back thermostat conditions) the last three feet of vent pipe can be reduced one nominal pipe size provided that the total vent length is at least 15 feet in length and the vent is sized in accordance with the venting requirements (Table 4) before this reduction is applied. (Example: 3" to 2-1/2") Smaller vent pipes are less susceptible to freezing, but must not be excessively restrictive.

Concentric Vent Termination

A concentric vent termination is approved for use with these furnaces. The kit part number is listed in Table 13. For proper installation of the concentric vent termination, follow the installation instructions provided with that kit.

DRAINAGE OF CONDENSATE FROM FURNACE

! WARNING:

The condensate produced by the furnace must be drained. Do not connect a water supply to the drainage hose of the furnace.

NOTE: The condensate drain should be protected from freezing when in unheated spaces.

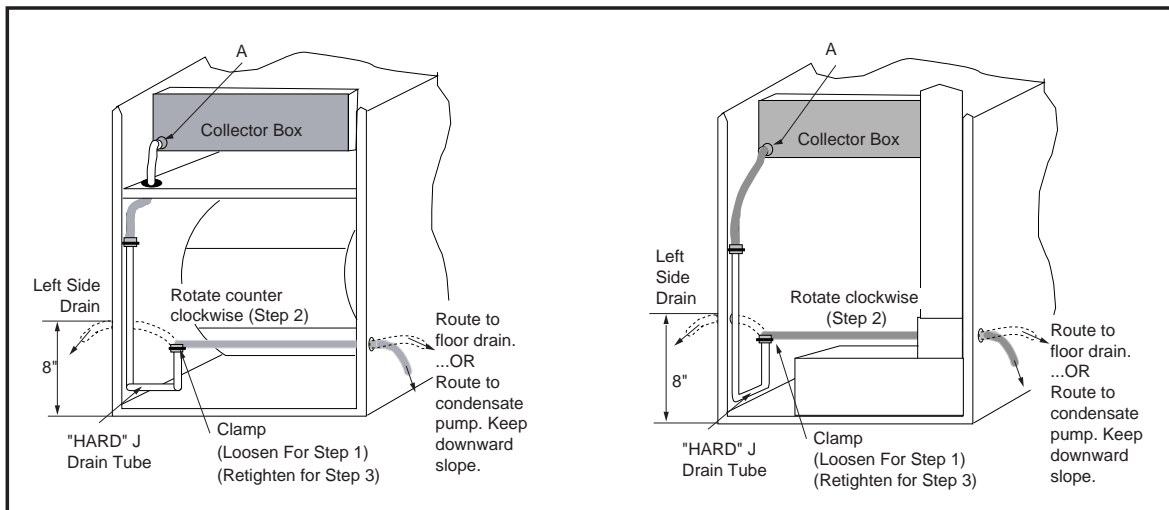

Figure 20. Furnace with Condensate Drain Trap Assembly

The condensate drainage system is internal to the furnace. The drain may exit either the right or left side of the furnace cabinet. For a right side drain, simply extend the tubing out of the 7/8" hole in the cabinet (See Figure 20).

For a left side drain follow the steps below:

1. Loosen the clamp on the soft exit tube (see Figure 20.)
2. Rotate the soft exit tube (counter clockwise, 180° upflow models; clockwise 90° downflow models.)
3. Re-tighten the clamp. **MAKE SURE CLAMP IS TIGHT TO AVOID LEAKAGE OF CONDENSATE.**
4. Route the tubing out of the 7/8" hole located 8 inches up from the bottom furnace.

The condensate should drain from the plastic collector box (location A in Figure 20) as droplets or a small stream. If you notice the furnace has operated for more than 5 minutes without draining or the red status light on the control board is pulsing a 2-blink code follow the steps below.

1. Remove the collector box soft tube at location A in Figure 20 and insure the exit from the collector box is clear of any debris or obstructions.
2. Replace this tube and insure the fit to the header spout is air tight. Air will be drawn into the header if this connection is not tight.
3. Check other tube connections along the drain system. Insure that all are air tight.

NOTE: Industry research studies indicate that when condensate is routed to an active drain, household detergents, etc., buffer its acidity. If the drain is not actively used or if codes require,

obtain a neutralizer kit (usually contains limestone). Proper drains and connections to the condensate tubing are required as NORDYNE cannot be held responsible for water leakage which occurs due to loose hose connections or improperly sealed drain line pipes.

GAS SUPPLY AND PIPING

General

This furnace is equipped for either left or right side gas entry. Typical gas service hook-ups are shown in Figure 21. When making the gas connection provide clearance between the gas supply line and the entry hole in the furnace casing to avoid unwanted noise and/or damage to the furnace.

All gas piping must be installed in compliance with local codes and utility regulations. Some local regulations require the installation of a manual main shut-off valve and ground joint union external to the furnace. The shut-off valve should be readily accessible for service and/or emergency use. Consult the local utility or gas supplier for additional requirements regarding placement of the manual main gas shut-off. In the absence of local codes, the gas line installation must comply with the provisions stated in the Federal Manufactured Home Standard (H.U.D Title 24, part 280 and the National Fuel Gas Code (ANSI Z223.1/NFPA-54) or (CAN/CGA B149) installation codes.

A drip leg should be installed in the vertical pipe run to the unit. Table 8 lists gas flow capacities for standard pipe sizes as a function of length in typical applications based on nominal pressure drop in the line.

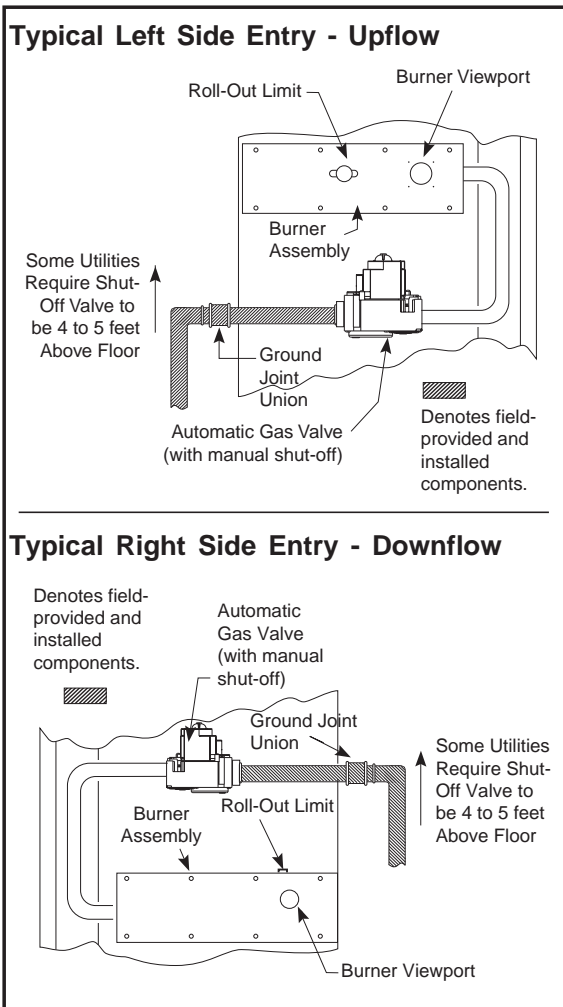

Figure 21. Typical Gas Service Connection

NOTE: Gas piping must not be run in or through air ducts, chimneys, gas vents, elevator shafts, etc.

Compounds used on threaded joints of gas piping must be resistant to the actions of liquefied petroleum gases.

The main manual gas valve and main power disconnect to the furnace must be properly labeled by the installer in case emergency shutdown is required.

! CAUTION:

Do not use matches, lighters, candles, or other sources of open flame to check for gas leaks.

NOTE: When pressure testing gas supply lines at pressures greater than 1/2 psig (14 in.

water column), the furnace must be disconnected from the gas supply piping system to prevent damage to the gas control valve.

If the test pressure is less than or equal to 1/2 psig (14 in. water column), the furnace must be isolated from the gas supply line by closing the manual shut-off valve.

Leak Check

After the gas piping to the furnace is complete, all connections must be tested for gas leaks. To check for leaks use only a soap and water solution or other approved method.

High Altitude Derate

The nameplate input rating for the furnaces apply for elevations up to 2,000 feet (610m) above sea level. For elevations over 2,000 feet, reduce the input by 4% for each 1,000 feet above sea level. For example, a furnace applied at an elevation of 5,000 feet should be derated by 20%. See Table 9 describing the correct orifice for derate.

NOTE: For Canadian high altitude (2,000 to 4,500 ft.), simply reduce the gas manifold pressure to 2.8" WC for natural gas and 8.5" WC for LP gas without changing the orifices.

NOTE: The density of air decreases with increasing elevation above sea level. This reduces the quantity of combustion air drawn into the furnace under normal operation and requires the unit be derated by using smaller gas orifices or lower manifold pressure.

CAPACITY OF BLACK IRON GAS PIPE (CU. FT. PER HOUR) FOR NATURAL GAS (SPECIFIC GRAVITY - 0.60)								
NOMINAL BLACK IRON PIPE DIAMETER (in.)	LENGTH OF PIPE RUN (feet)							
	10	20	30	40	50	60	70	80
1/2	130	90	75	65	55	50	45	40
3/4	280	190	150	130	115	105	95	90
1	520	350	285	245	215	195	180	170
1 1/4	1050	730	590	500	440	400	370	350
1 1/2	1600	1100	890	760	670	610	560	530

The cubic feet per hour listed in the table above must be greater than the cubic feet per hour of gas flow required by the furnace.

To determine the cubic feet per hour of gas flow required by the furnace, divide the input rate of the furnace by the heating value of the gas:

$$\text{Cubic Feet Per Hour Required} = \frac{\text{Input To Furnace (Btu/hr)}}{\text{Heating Value of Gas (Btu/Cu. Ft.)}}$$

Table 8. Capacity of Black Iron Gas Pipe (cu. ft. per hour) for Natural Gas (specific gravity = .60)

CONVERSION

This furnace can be converted from the factory-equipped gas to either natural gas (for LP gas ready models), or LP gas (for natural gas ready models). Conversions must be made by qualified service personnel, using only factory authorized or approved parts. The required conversion orifices are supplied with the furnace.

 **WARNING:**

DO NOT REMOVE OR DEFACE THE ORIGINAL RATING PLATE.

 **CAUTION:**

The gas supply shall be shut off prior to disconnecting the electrical power, before proceeding with the conversion.

To Turn Off Fuel Supply to the Appliance:

1. Set the room thermostat to "OFF" or its lowest temperature setting.
2. Turn OFF the main gas supply to the appliance at the manual valve, outside of the appliance casing.
3. Remove the control access panel / louvered door.

4. Move the appliance gas valve lever/knob to the "OFF" position.
5. Turn OFF the electrical power to the appliance.

To Remove the Burner Assembly:

1. Follow the instructions "To Turn Off the Fuel Supply to the Appliance."
2. Disconnect the flame sensor wire from the burner box.
3. Disconnect the igniter wires at the 2 pin plug. This is a locking quick connect and both sides of the lower section must be depressed in order to be separated.
4. Remove the wires from the terminals of the gas valve.
5. Disconnect the rubber pressure tubes from the gas valve and the burner box.
6. Remove the burner access cover plate from the burner box.
7. Remove supply gas piping from the gas valve.
8. Carefully remove the burner assembly fasteners and remove the burner assembly from the appliance. Keep the fasteners that were removed. Note that the burner box may have hooks near the top and on the right and left hand sides. To remove this type of burner box, lift the burner box upwards and then remove the box from the unit.

EXAMPLE 1

Elevation	3,890 feet
Type of gas	Natural
Furnace model	M2RC-100A-16-BN
Orifice as shipped	#45 Drill

What burner orifices are needed?

The required input for 3890 feet is 84,000 Btuh or 16% less than the sea level rating of 100,000 Btuh.

See Table 8 for natural gas, find the Furnace Model Number and follow across the table for the elevation 2000-4000 column. From the table, choose a #46 orifice. Install a #46 orifice in every burner and check the firing rate per the VERIFYING AND ADJUSTING FIRING RATE section. The firing rate in this example must not exceed 84,000 Btuh.

EXAMPLE 2

Elevation	5,500 feet
Type of gas	Propane
Furnace model	M2RC-100A-16-BN
Orifice in Natural to LP Conversion Kit	# 55 drill

What burner orifices are needed?

The required input for 5500 feet is 76,000 Btuh or 24% less than the sea level rating of 100,000 Btuh.

See Table 8 for LP gas, find the Furnace Model Number and follow across the table for the elevation 4000-6000 column. From the table, choose a #56 orifice. Install a #56 orifice in every burner and adjust the manifold pressure to 10.0 inches water column. The firing rate in this example must not exceed 76,000 Btuh.

Furnace Model Number M2R(C,L) -	Furnace Rating Plate Input (Btuh)	No. of Burners	Elevation 0 - 2000		Elevation 2000-4000		Elevation 4000-6000		Elevation 6000-8000		Elevation 8000-10000	
			Nat	LP	Nat	LP	Nat	LP	Nat	LP	Nat	LP
060A-16-B(*)	60,000	4	49	56	49	56	50	57	50	57	51	58
080A-16-B(*)	80,000	4	45	55	46	55	49	56	49	56	50	57
100A-16-B(*)	100,000	5	45	55	46	55	49	56	49	56	50	57

*can be N or L

Table 9. Approximate Orifice Size for Natural and LP Gases

To Remove the Burner Orifices:

1. Remove the four (4) fasteners that secure the gas manifold to the burner box, as shown in Figure 24. Carefully remove the gas manifold assembly from the burner box. Note that the gas manifold assembly consists of the gas valve, the gas manifold, and the orifices.
2. Carefully remove the burner orifices from the gas manifold, as shown in Figure 24.

! CAUTION:

Caution: Do not re-drill the burner orifices. If the orifice size must be changed, use only new orifices.

Note: The size of the new orifices that will be installed into the unit will depend upon the type of conversion (sea level or high altitude; natural gas or LP gas).

To Convert the Unit to the Alternate Gas

1. Remove the orifice bag from the manifold of the unit.
2. Install the appropriate gas burner orifices into the gas manifold. Remember if installing in the United States at altitudes above 2,000 feet to install the proper orifices, shown in Table 6. When installing the new orifices, **DO NOT** use pipe joint compound on the orifice threads. Screw the orifices into the manifold by hand until snug to eliminate cross threading, then tighten with a wrench. Before installing an orifice, check the face or side of the orifice for the drill number to ensure that it is the appropriate size.
3. For the conversion to the alternate fuel, the gas valve regulator cap must be turned over, as shown in Figure 22. You will unscrew the cap and reinstall for your installation. After reinstalling the cap, you will be able to read "NAT" for the conversion to natural gas or "LP" for the conversion to LP gas.

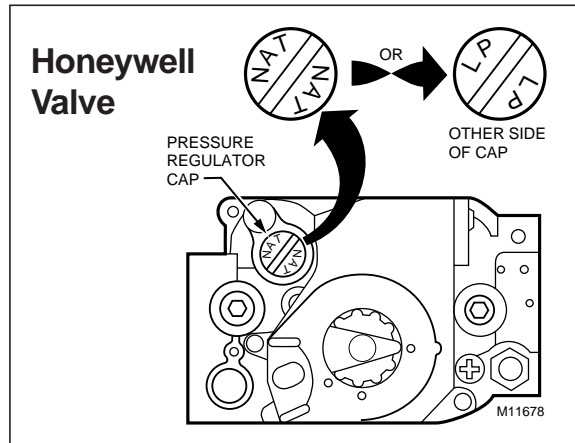

Figure 22. Convertible Pressure Regulator Cap

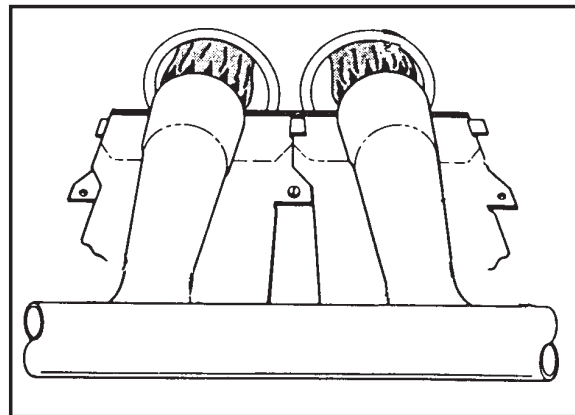

Figure 23. Burner Inspection

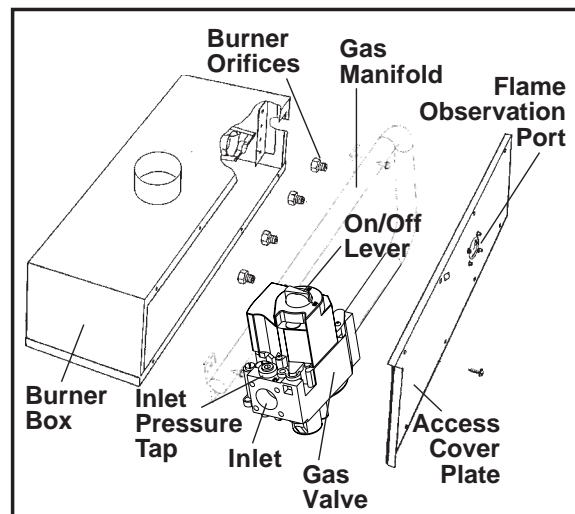

Figure 24. Typical Installation For Sealed Burner Box With Access Cover Plate

Reinstalling the Burner Assembly:

1. Reinstall the gas manifold assembly to the burner box with the four (4) fasteners, which were removed earlier.
2. Carefully reinstall the burner box into the unit. After installing the burner, inspect the alignment of the burners with the heat exchanger tubes. The center of the burners should be aligned with the center of the tubes.
3. Reconnect the gas piping to the gas valve.
4. Reconnect the wires to the gas valve terminals.
5. Reconnect the rubber pressure tubes to the gas valve and the burner box. Reinstall the burner access cover plate.
6. Reconnect the igniter at the 2 position plug.
7. Reconnect the flame sensor wire to the burner box.

Pressure Gauge Installation

NOTE: For natural gas installations, the incoming gas line pressure at the gas valve inlet must be between 4.5" WC and 10.0" WC. For LP gas installations, the incoming gas line pressure at the gas valve inlet must be between 11.0" WC and 14.0" WC. This pressure can be checked at the inlet end of the gas valve using a pressure gauge or U-tube manometer, which must be installed according to the manufacturer's supplied instructions.

LIGHTING AND ADJUSTMENT OF THE APPLIANCE

1. Turn ON the gas at the manual valve, outside of the unit.
2. Check all gas connections for leaks with a soap and water solution. If the solution bubbles there is a gas leak which must be corrected. Do NOT use an open flame to check for gas leaks.
3. Turn ON the electrical power to the appliance.
4. Move the gas valve lever/knob to the "ON" position. The lever/knob must be moved to the end of its range of motion to insure the valve is completely open. Use only your hand to push in or turn the gas control valve. Never use tools.
5. Set the room thermostat to a point above room temperature to begin the heating cycle of the unit.

6. Check that the unit ignites and operates properly. Refer to the installation instructions provided with your unit for the normal operating sequence.
7. After the flame ignites, visually inspect the burner assembly to ensure that the flame is drawn directly into the center of the heat exchanger tube, as shown in Figure 23. The end of the flame will be out of sight around the bend of the heat exchanger tube. In a properly adjusted burner assembly, the flame color should be blue with some light yellow streaks near the outer portions of the flame.

NOTE: Until all of the air is bled out of the gas line, the hot surface igniter may not ignite the gas. If the ignition control locks out, turn the thermostat to its lowest setting and wait one minute then turn the thermostat to a point above room temperature and the igniter will try again to ignite the main burners. This process may have to be repeated several times before the burners will ignite. Once the burners are lit, check all gas connections for leaks again with the soap and water solution. If the solution bubbles there is a gas leak which must be corrected. Do not use an open flame to check for gas leaks.

Adjusting the Manifold Pressure

The manifold pressure can be measured by installing a pressure gauge or U-tube manometer to the outlet end of the gas valve as follows:

1. With a 3/16" Allen wrench, remove the manifold pressure tap plug located on the outlet side of the gas valve. Refer to Figure 3 for more details.
2. A fitting, which has a 1/8" NPT pipe thread that is compatible with the pressure gauge or U-tube manometer, must be installed at this point.
3. Install the pressure gauge or U-tube manometer according to the manufacturer's supplied instructions.
4. Set the room thermostat to a point above room temperature to start the furnace.
5. Allow the furnace to operate for three (3) minutes and then check the manifold pressure.
6. Table 10 lists the appropriate manifold pressures for both natural gas and propane (LP) gas installations. For the type of fuel and the altitude of your installation,

	Natural Gas	Propane (LP)
Manifold Pressure for 0-2000 Feet Above Sea Level (In WC)	3.5	10.0

Table 10. Manifold Pressures for Sea Level

determine the required manifold pressure. For Canadian high altitude installations, refer to the "High Altitude Derate" section for more details.

COMPLETING THE CONVERSION

1. Affix the gas valve conversion label found in the package with the orifices to the unit rating plate.
2. Run the appliance through a complete cycle to assure proper operation.

! CAUTION:

To avoid electric shock, personal injury, or death, turn off the power at the disconnect or the main service panel before making any electrical connections.

ELECTRICAL WIRING

General

Electrical connections must be made in accordance with all applicable local codes and ordinances, and with the current revision of the National Electric Code (ANSI/NFPA 70).

For Canadian installations electrical connections and grounding must be done in accordance with the current Canadian Electrical Code (CSA C22.1 Part 1) and/or local codes. If any of the original wire as supplied with the furnace must be replaced, it must be replaced

with wire having a minimum temperature rating of 105°C. Refer to the furnace nameplate and Table 8 for electrical requirements.

Line Voltage Wiring

The line voltage (115 volt) to the furnace must be supplied from a dedicated branch circuit containing the correct fuse or circuit breaker for the furnace. See Table 11. An electrical switch should be readily accessible from and within sight of the furnace. See the Wiring Diagram label in the furnace for more details.

The furnace cabinet must have an uninterrupted, unbroken ground to minimize injury should an electrical fault condition occur. The controls used in this furnace require an earth ground to operate properly. Acceptable methods for grounding are electrical wire or conduit approved for electrical ground service. Do not use gas piping as an electrical ground.

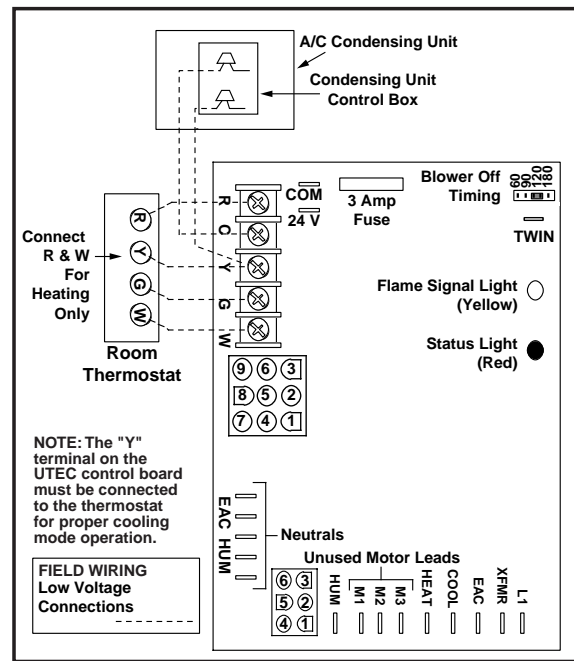

Figure 26. Low Voltage Field, Four-wire Heating/Cooling Applications

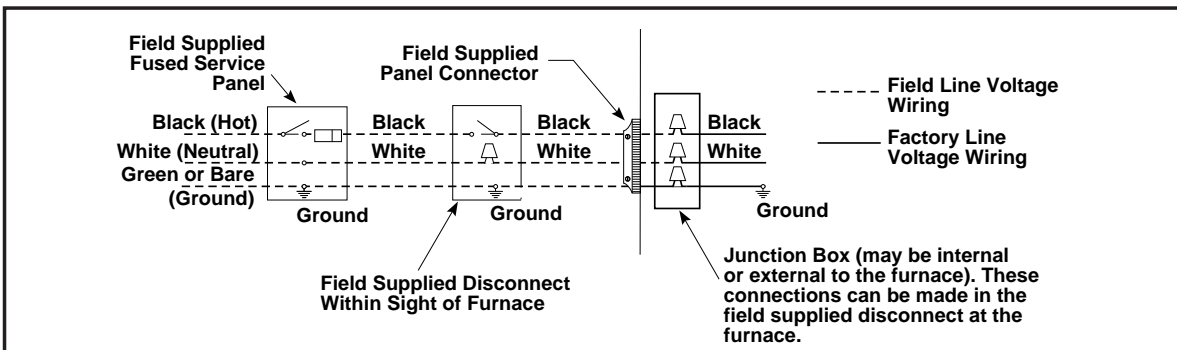

Figure 25. Line Voltage Field Wiring

Furnace Input (Btuh)	Cabinet Width (in.)	Nominal Electrical Supply	Maximum Operating Voltage	Minimum Operating Voltage	Maximum Furnace Amperes	Minimum Wire Gauge	Maximum Fuse or Circuit Breaker Amps*
60,000	19.75	115-60-1	127	103	9.7	14	15
80,000	19.75	115-60-1	127	103	9.7	14	15
100,000	19.75	115-60-1	127	103	9.7	14	15
Thermostat Wire Gauge				Recommended Thermostat Wire Length			
				2-wire (heating)		4 or 5-wire (cooling)	
24				55 ft.		25 ft.	
22				90 ft.		45 ft.	
20				140 ft.		70 ft.	
18				225 ft.		110 ft.	

* Time-delay fuses or HACR-type circuit breakers are required.

Table 11. Electrical Data

NOTE: Proper line voltage polarity must be maintained in order for the control system to operate correctly. Verify that the incoming neutral line is connected to the white wire and the incoming "hot" line is connected to the black wire in the furnace junction box. The furnace will not operate unless polarity and ground are properly connected. See Figure 25.

! CAUTION:

Label all wires prior to disconnection when servicing controls. Wiring errors can cause improper and dangerous operation.

Verify proper operation after servicing.

! ATTENTION:

Lors des opérations d'entretien des commandes, étiqueter tous les fils avant des les déconnecter. Toute erreur de câblage peut être une source de danger et de panne.

S'assurer du bon fonctionnement de l'appareil après tout entretien.

Low Voltage Wiring

Install the thermostat per the manufacturer's instructions. The low voltage (24 volt) connections from the thermostat are made at the terminal strip on the control board in the furnace. See Figure 26 for the proper connections

for heating only (two-wire) and heating/cooling (four-wire) applications. The recommended minimum wire gauge for thermostat wiring is shown in Table 11.

The thermostat must not be installed on an outside wall or any other location where its operation may be adversely affected. Adverse affects include radiant loading from fireplaces, sunlight, or lighting fixtures, and convective loading from warm air registers or electrical appliances.

To check the heat anticipator setting either:

1. Add the current draw of the system components; or
2. Measure the current flow on the thermostat R-W circuit after the circulating blower motor has started.

Set the heat anticipator according to the thermostat manufacturer's instructions for heat anticipator settings.

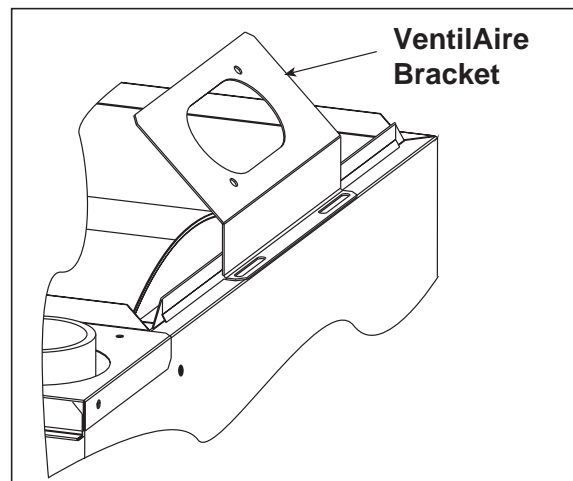

Figure 27. Ventilation Bracket

VENTILATION

Ventilation must be provided for homes built to HUD Manufactured Homes Safety and Construction Standards. This ventilation can be supplied by the VentilAire III or VentilAire IV accessories (see Table 13). Alternate means to provide the ventilation air must meet the requirements of all applicable local and federal codes.

For downflow models, a bracket is supplied with the furnaces to allow the use of the VentilAire III or VentilAire IV accessories. The bracket is installed on the right hand side at the top of the cabinet, as shown in Figure 27. The bracket can be fastened using the self-drilling screws supplied with the unit.

For upflow models, the means to provide the required ventilation must be incorporated into the upflow furnace base or the return air ductwork to the furnace.

For installation of the VentilAire III or IV, follow the instructions provided with the VentilAire kit.

START-UP AND ADJUSTMENTS

General

Prior to start-up, verify that:

1. The line voltage power leads are securely connected, that the polarity of the connections is correct, and that the furnace is properly grounded.
2. The thermostat wires (R, W, Y, and G) are securely connected to the correct leads on the terminal strip of the circuit board.
3. The natural gas line service pressure must not exceed 10.0 in. water column (0.36 psig), and must not be less than 4.5 in. water column (0.16 psig). For LP gas the line service pressure must not exceed 14 in. water column (0.51 psig), and must not be less than 11.0 in. W.C. (0.40 psig).
4. The roll-out and vent safety manual reset switches are closed. If necessary, press the red button to reset a switch. See Figure 31 for location. DO NOT install a jumper wire across a switch to defeat its function. If a switch reopens on start-up, DO NOT reset the switch without identifying and correcting the fault condition which caused the switch to trip.
5. The blower door is in place, closing the door switch in the line voltage circuit.
6. The gas line has been purged and all connections are leak tight.

Start-Up Procedure

1. Set the thermostat to the lowest setting.
2. Close the disconnect(s) to provide line voltage to the furnace.
3. Follow the procedures given on the operating instructions label attached to the furnace.
4. Set the thermostat above room temperature and verify the sequence of operation. (See the **SEQUENCE OF OPERATION**.)
5. After the furnace has run for approximately five minutes, set the thermostat below room temperature and verify steps 9 - 11 of the **SEQUENCE OF OPERATION**.

Shut Down Procedure

In the event that the furnace must be shut down, follow this procedure:

1. Set the room thermostat to "OFF" or its lowest temperature setting.
2. Turn OFF the main gas supply to the appliance at the manual valve outside of the appliance casing.
3. Remove the control access panel / louvered door.
4. Move the appliance gas valve lever/knob to the "OFF" position.
5. Turn OFF the electrical power to the appliance.

Verifying and Adjusting Firing Rate

The firing rate must be verified for each installation to prevent over-firing the furnace.

NOTE: The firing rate must not exceed the rate shown on the furnace rating plate. At altitudes above 2000 ft. it must not exceed that on the rating plate less 4% for each 1000 ft.

Use the following procedure to determine the firing rate:

1. Shut off all other gas fired appliances.

GAS FLOW RATE (CUBIC FEET PER HOUR)							
TIME FOR ONE REVOLUTION (SECONDS)	CUBIC FEET PER REVOLUTION OF METER			TIME FOR ONE REVOLUTION (SECONDS)	CUBIC FEET PER REVOLUTION OF METER		
	1	5	10		1	5	10
24	150	750	1500	80	45	225	450
26	138	692	1385	82	44	220	439
28	129	643	1286	84	43	214	429
30	120	600	1200	86	42	209	419
32	113	563	1125	88	41	205	409
34	106	529	1059	90	40	200	400
36	100	500	1000	92	39	196	391
38	95	474	947	94	38	191	383
40	90	450	900	96	38	188	375
42	86	429	857	98	37	184	367
44	82	409	818	100	36	180	360
46	78	391	783	102	35	176	353
48	75	375	750	104	35	173	346
50	72	360	720	106	34	170	340
52	69	346	692	108	33	167	333
54	67	333	667	110	33	164	327
56	64	321	643	112	32	161	321
58	62	310	621	114	32	158	316
60	60	300	600	116	31	155	310
62	58	290	581	118	31	153	305
64	56	281	563	120	30	150	300

Table 12. Gas Flow Rate

- Start the furnace and allow it to run for at least three minutes.
- Measure the time (in seconds) required for the gas meter to complete one revolution.
- Convert the time per revolution to cubic feet of gas per hour using Table 12.
- Multiply the gas flow rate in cubic feet per hour by the heating value of the gas in Btu per cubic foot to obtain the firing rate in Btuh. Example:
 - Time for 1 revolution of a gas meter with a 1 cubic foot dial = 40 seconds.
 - From Table 11 read 90 cubic feet per hour of gas.
 - Heating value of the gas (obtained from gas supplier) = 1040 Btu per cubic foot.
 - Firing rate = 1040 x 90 = 93,600 Btuh.
- Relatively small adjustments to the firing rate can be made by adjusting the gas manifold pressure.
- See the "High Altitude Derate" section for additional information on firing rate at elevations above 2000 ft.

The gas valve regulator is set at a nominal value of 3.5 in. water column for use with natural gas. The manifold pressure must be set at 10.0 in. water column for use with LP gas. To adjust the manifold pressure, remove the regulator cap and turn the adjusting screw

clockwise to increase pressure or counter-clockwise to reduce pressure. Replace the regulator cap after adjustments are complete.

Verifying and Adjusting Temperature Rise

Verify that the temperature rise through the furnace is within the range specified on the furnace rating plate. Temperature rises outside the specified range could result in premature heat exchanger failure.

Place thermometers in the return and supply air stream as close to the furnace as possible. The thermometer on the supply air side must be shielded from direct radiation from the heat exchanger to avoid false readings. Adjust all

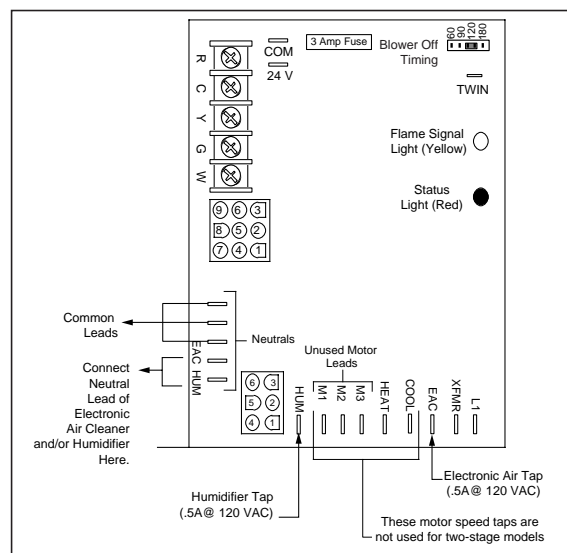

Figure 28. Blower Speed Tap Location

registers and duct dampers to the desired position and run the furnace for fifteen minutes before taking any temperature readings. The temperature rise is the difference between the supply and return air temperatures.

For typical duct systems, the temperature rise will fall within the range specified on the rating plate with the blower speed at the factory recommended setting. If the temperature rise measured is outside the range specified, it may be necessary to change the blower speed. Lower blower speeds will increase the temperature rise and higher blower speeds will decrease the temperature rise.

The furnace is equipped with a multispeed motor. Heating and cooling speed selection is made by moving the leads on the integrated control board located in the furnace. The wiring diagram on the furnace and Figure 28 show the speed taps for adjusting motor speed.

If it is desired that the blower operate at the same speed for heating and cooling, tape off the terminal of the unused blower wire. Install the jumper wire, found in the plastic instruction bag, across the HEAT and COOL taps on the control board. Reconnect the desired blower tap to the piggyback quick connect.

The blower control is designed to start the circulating air blower 30 seconds after the gas valve is opened. The blower control is factory wired to turn the blower motor off 120 seconds after the gas valve is closed. This timing can be changed using the BLOWER OFF timing switch opposite the terminal block on the control board (See Figure 28).

Verifying Burner Operation

To verify operation of the burners, make sure that the blower compartment door is in place and that there is power to the furnace. Set the thermostat above room temperature and observe the ignition sequence. The flame can be observed through the small clear window on the burner box. The burner flame should carry over between all burners. The flames should be blue, without yellow tips. Flames should extend from each burner without lifting, curling, or floating. After verifying ignition, set the thermostat below room temperature and verify that the burner flame extinguishes completely.

Verifying Operation of the Supply Air Limit Switch

To verify operation of the supply air limit switch, make sure that the blower door is in place and that

there is power to the furnace. Completely block the return airflow to the furnace by installing a close-off plate in place of or upstream of the filter(s). Set the thermostat above room temperature and verify that the Sequence of Operation is as described in these instructions. The supply air limit switch should function to turn off the gas valve within approximately five minutes. The circulating air and combustion blowers should continue to run when the supply air limit switch opens. Remove the close-off plate immediately after the supply air limit switch opens. If the furnace operates for more than five minutes with no return air, set the thermostat below room temperature, shut off the power to the furnace, and replace the supply air limit switch.

DESCRIPTION OF COMPONENTS

Figure 31 shows the location of each of the functional components described below. If any component of the furnace must be replaced, use only factory authorized replacement parts. Contact your distributor for the approved replacement parts.

Flame Sensor – The flame sensor acts to prove that flame has carried over from the igniter to the opposite end burner. If no flame is sensed, the furnace will be shut down automatically.

Gas Valve – The gas valve controls the flow of gas to the burners. When the gas valve is energized it automatically opens and regulates the gas pressure in the manifold.

Pressure Switch – The pressure switch verifies that the inducer is drawing the combustion gases through the heat exchanger. It also senses a blocked condensate drain condition.

Vent Pressure Switch (Downflow models only) – The vent pressure switch reacts to blockage in the vent or combustion air piping.

Supply Air Limit Switch – The supply air limit switch prevents the air temperature leaving the furnace from exceeding the maximum outlet air temperature.

Vent Safety Switch – The vent safety switch shuts the furnace down if the outlet flue gas temperature increases above 160°F. This switch protects the plastic flue system and the inducer from over-temperature conditions.

Flame Roll-Out Switch – This switch provides flame roll-out protection to the furnace and combustion air inlet pipe.

MAINTENANCE

It is recommended that the furnace be checked yearly. At a minimum, this check should include the following items:

WARNING:

To avoid electric shock, personal injury, or death, turn off the power at the disconnect or the main service panel before performing any maintenance.

WARNING:

Holes in the vent pipe or heat exchanger can cause products of combustion to enter the occupied space. Replace the vent pipe or heat exchanger if leaks are found. Failure to prevent products of combustion from being circulated into the occupied space can create potentially hazardous conditions, including carbon monoxide poisoning, that could result in personal injury or death.

Combustion Air and Vent System

Check the combustion air and vent pipe to ensure that it is not damaged, corroded or blocked by debris. Any damaged section of vent pipe must be replaced, and any obstruction or blockage must be removed prior to operating the furnace.

Air Filter(s)

An air filter is supplied with the furnace as shipped from the factory. Filters should be changed or cleaned monthly during the heating season. New or newly renovated homes may require more frequent changing until the construction dust has been removed.

For the upflow model, the air filter is located underneath the blower in the blower compartment. To remove the filter, first remove the lower door. Then, slide the filter backwards until the edge of the filter clears the front flange of the

furnace. Lift the filter up over the flange and then remove. Reinstall the filter in the reverse manner. Ensure that the filter is centered over the return opening of the furnace, and is captured by the fastener at the rear of the furnace.

For the downflow model, the filter is at the top of the furnace. The filter can be removed by lifting the filter upwards and out of the opening. Reinstall the filter in the reverse manner. Ensure that the filter is securely held by the braces on either side of the return air opening.

WARNING:

Never operate the furnace without a filter in place. Dust and lint in the return air can build up on internal components, resulting in loss of efficiency, equipment damage, and possible fire.

Lubrication

The bearings in the circulating air blower motors are pre-lubricated and sealed at the factory. No further oiling of the bearings is required for the life of the motor.

Condensate Drain Assembly

Be sure the condensate lines are free and open (i.e. avoid kinking hoses). Also make sure all hose clamps are tight to avoid drawing air into the system.

Blower Compartment

The blower compartment should be cleaned monthly during the heating and cooling seasons to remove any dirt and lint that may have accumulated in the compartment or on the blower and motor. Dirt and lint can create excessive loads on the motor resulting in higher than normal operating temperatures and shortened service life.

Heat Exchanger and Burner Maintenance

The furnace should operate for many years without excessive soot buildup in the flue passageways, however, the flue passageways, the vent system, and the burners should be inspected and cleaned (if required) by a qualified service technician annually to ensure continued safe operation. Particular attention must be given to identify deterioration from corrosion or other sources.

SYSTEM OPERATION INFORMATION

General

Proper maintenance is most important to achieve the best performance from a furnace. Follow these instructions for years of safe, trouble free operation.

- Do not place combustible materials on or against the furnace cabinet or the vent pipe.
- Do not store gasoline or any other flammable vapors and liquids in the vicinity of the furnace.
- Change or replace the air filters monthly during any period when the circulating blower is operating regularly.
- Always replace the doors on the furnace after servicing. Do not operate the furnace without all doors and covers in place.
- Avoid operating the furnace when windows and doors are open.
- **Be sure that the thermostat is properly installed and is not being affected by drafts or heat from lamps or other appliances.**

Sequence of Operation

Operating sequences for the heating, cooling, and fan modes are described below. Refer to the wiring diagrams (Figures 31 and 32) and the low voltage field wiring diagram (Figure 26) for more details.

Heating Mode:

1. On a call for heat the thermostat closes, applying 24 VAC to the W terminal on the control board.
2. The control board checks for continuity on the 24 VAC limit control circuit (over-temperature limit switch, flame rollout switches and blocked vent switch in series). If an open limit is detected the control board will energize the inducer and the conditioned air blower. All other system functions will be inoperable until the limit circuit closes. While the limit is open, the red LED will pulse at a rate of 1 blink per unit time.
3. The furnace control checks for continuity across the pressure switch (24 VAC). If the pressure switch is closed the heat

mode sequence will not continue. If it remains closed for 10 seconds the red LED will blink 3 times repetitively until the fault condition clears.

4. The inducer is energized.
5. The pressure switch will close. If the pressure switch does not close after 10 seconds the fault LED will blink 2 times repetitively and the inducer will continue to run until the switch is closed.
6. The inducer will pre-purge for 30 seconds and then the igniter will start its warm-up as follows:
Initial Power up: After 30 seconds of igniter warm-up the gas valve (24 VAC) will then open. The igniter circuit will stay energized for 3 seconds after the gas valve opens.
After Initial Power up: The control has a programmed adaptive ignition feature which varies the warm-up period as follows: If ignition is successful the warm-up is reduced by 3-seconds on each subsequent call for heat until ignition failure occurs. Upon ignition failure, the warm-up is increased by 3-seconds on the next try. If successful, the timing remains fixed at this level. In general, whenever ignition failure occurs the warm-up interval is increased by 3-seconds on the next try. And if successful, it remains there. Minimum and maximum warm-up time limits are set at 6 and 54-seconds, respectively.
7. The furnace control must prove flame via the flame sensor 5 seconds after the gas valve opens. If flame is sensed, all burners are on and the igniter cools off. If no flame is sensed, the gas valve closes immediately and the inducer continues to run. A second trial for ignition (step 6) begins if no flame is sensed. On the fifth try for ignition, the furnace control is locked out and the red LED will blink 4 times repetitively. The thermostat must be opened for at least ten seconds to reset the furnace control after a lock out. Otherwise, the furnace will attempt another ignition sequence in 1 hour.
8. The furnace control energizes the circulating air blower on the heating speed 30 seconds after the gas valve circuit is energized .
9. When the thermostat has been satisfied, gas valve is de-energized.
10. The inducer is de-energized after a 30-second postpurge.

11. The furnace control keeps the circulating air blower energized for 120 seconds (factory set) or 60, 90, or 180 seconds (field adjustable). (See Figure 28.)
12. Abnormal conditions: If a limit opens during operation, the inducer and circulating air blower continue to operate. The gas valve is de-energized immediately. The blowers continue to operate until the limit closes. When the limit closes the inducer blower is de-energized immediately. The circulating air blower continues to operate for the specified delay (factory set at 120 seconds).

Cooling Mode:

1. On a call for cooling the thermostat closes, applying 24 VAC to the G and Y terminals on the furnace control. This closes the compressor contactor.
2. The furnace control energizes the circulating blower (115 VAC) on the cooling speed.
3. When the thermostat is satisfied, the G and Y terminals on the control board are de-energized opening the compressor contactor.
4. The circulating air blower is de-energized after a 90-second delay.

Fan Mode:

1. On a call for fan operation, the thermostat applies 24 VAC to the G terminal on the furnace control board.
2. The circulating air blower is energized immediately on the heating speed.
3. If the furnace is operated in the continuous ON position at the thermostat and is then switched to AUTO, the circulating blower will operate for a specified delay (factory set at 120 seconds).

Furnace Fails to Operate

If the furnace does not operate check the following:

1. Is the thermostat operating properly?
2. Are the blower compartment door(s) in place?
3. Is the furnace disconnect closed?
4. Has the circuit breaker tripped or the control board fuse burned open?
5. Is the gas turned on?
6. Are any manual reset switches open?
7. Is the filter dirty or plugged?
8. Is the flame sensor coated? (Remove and clean with emery cloth.)

If the furnace locks out after 5 attempts for ignition, it will try again every hour if a call for heat remains. If the inducer and circulating air blowers are operating, and items 1 through 8 have been checked, press the red reset button on the vent safety switch. (See Figure 30.) If the furnace operates after depressing the reset button, contact a qualified service technician to identify and repair the problem.

If furnace continues to not operate, depress the red reset buttons on the flame roll-out switch. If the furnace operates after depressing the reset button, contact a qualified service technician to identify and repair the problem.

FURNACE ACCESSORY KITS

Kit	Order Number
Fossil Fuel Kit	914762
A/C Coil Box	914958
Sloped Roof VentilAire III Kit	914098
Sloped Roof VentilAire IV Kit	914229
Soffit VentilAire Kit	917201
Concentric Vent Termination Kit (for horizontal and vertical venting)	904176 (3 Inch) 904177 (2 Inch)
Horizontal Exterior Vent Mounting Kit	2"PVC 902373 3"PVC 902375
Neutralizer Kit - All Models	902377

Table 13. Accessory Kits

Upflow Furnace

- 1 Manifold
- 2 Flame Sensor (Not Shown)
- 3 Gas Valve
- 4 Roll-Out Limit Switch (155°F)
- 5 Pressure Switch
- 6 Control Board, Integrated
- 7 Blower Door Switch
- 8 Vent Safety Limit Switch (160°F)
- 9 Transformer
- 10 Limit Switch
- 11 Blower Assembly
- 12 Inducer Blower (with gasket)
- 13 J Trap Hard Tube
- 14 In-Line Drain Assembly
- 15 Burner Box Assembly (Nat. and LP Gas Ready)
- 16 Header Outlet Box
- 17 Cased Coil Wrapper
- 18 Filter (18 5/8 x 26 1/2 x 1/4) (Not Shown)
- 19 Attachment Bracket
- 20 Turbulator (Not Shown)
- 21 Coupling Neoprene
- 22 Orifice, Inducer (Not Shown)
- 23 Inshot Burner (Not Shown)
- 24 Natural and LP Gas Orifice (Not Shown)
- 25 Igniter (Not Shown)
- 26 Heat Exchanger Assembly (Not Shown)
- 27 Capacitor Assembly, 10 MFD, 370V (Not Shown)
- 28 Blower Wheel CCW (Not Shown)
- 29 Motor - 1/2 HP (4 Speed) (Not Shown)
- 30 Access Doors, Set (Not Shown)

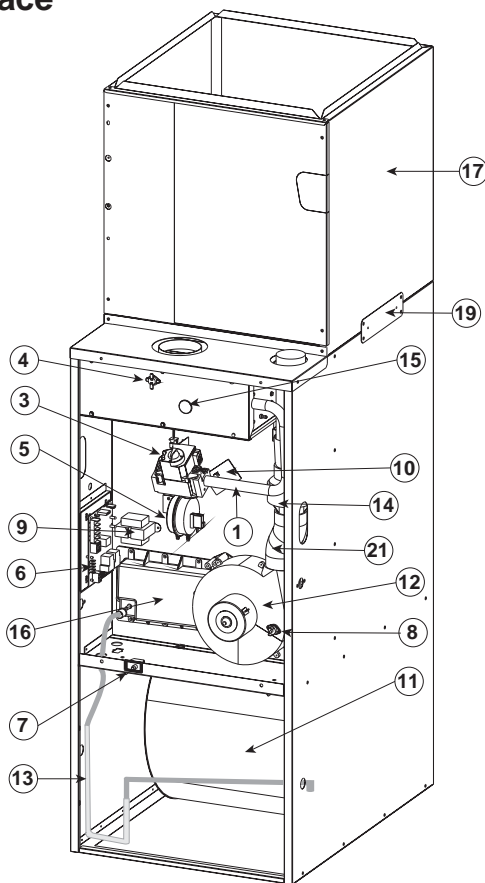

Downflow Furnace

- 1 Manifold
- 2 Flame Sensor (Not Shown)
- 3 Gas Valve
- 4 Roll-Out Limit Switch (155°F)
- 5 Pressure Switch
- 6 Integrated Control Board
- 7 Blower Door Switch (Not Shown)
- 8 Vent Safety Limit Switch (160°F)
- 9 Transformer
- 10 Limit Switch
- 11 Blower Assembly
- 12 Inducer Blower (with gasket)
- 13 J Trap Hard Tube
- 14 In-Line Drain Assembly
- 15 Burner Box Assembly
- 16 Header Outlet Box
- 17 Cased Coil Wrapper
- 18 Filter (18 x 20 x 1) (Not Shown)
- 19 VentilAire Bracket
- 20 Attachment Bracket
- 21 Turbulator (Not Shown)
- 22 Auxillary Limit Switch (120°) (Not Shown)
- 23 Inducer Orifice (Not Shown)
- 24 Inshot Burner (Not Shown)
- 25 Natural and LP Gas Orifice (Not Shown)
- 26 Igniter (Not Shown)
- 27 Heat Exchanger Assembly (Not Shown)
- 28 Capacitor Assembly, 10 MFD, 370V (Not Shown)
- 29 Blower Wheel CCW (Not Shown)
- 30 Motor - 1/2 HP (Not Shown)
- 31 Access Door (Not Shown)

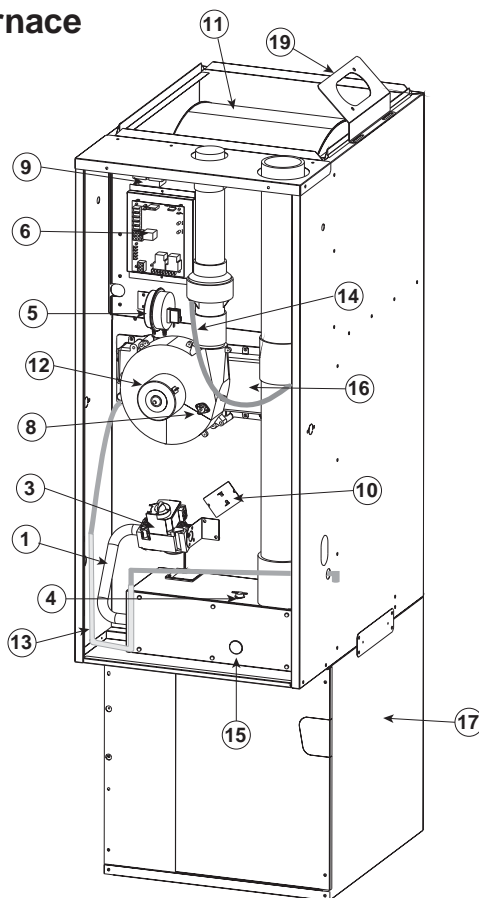

Figure 30. Location of Major Components

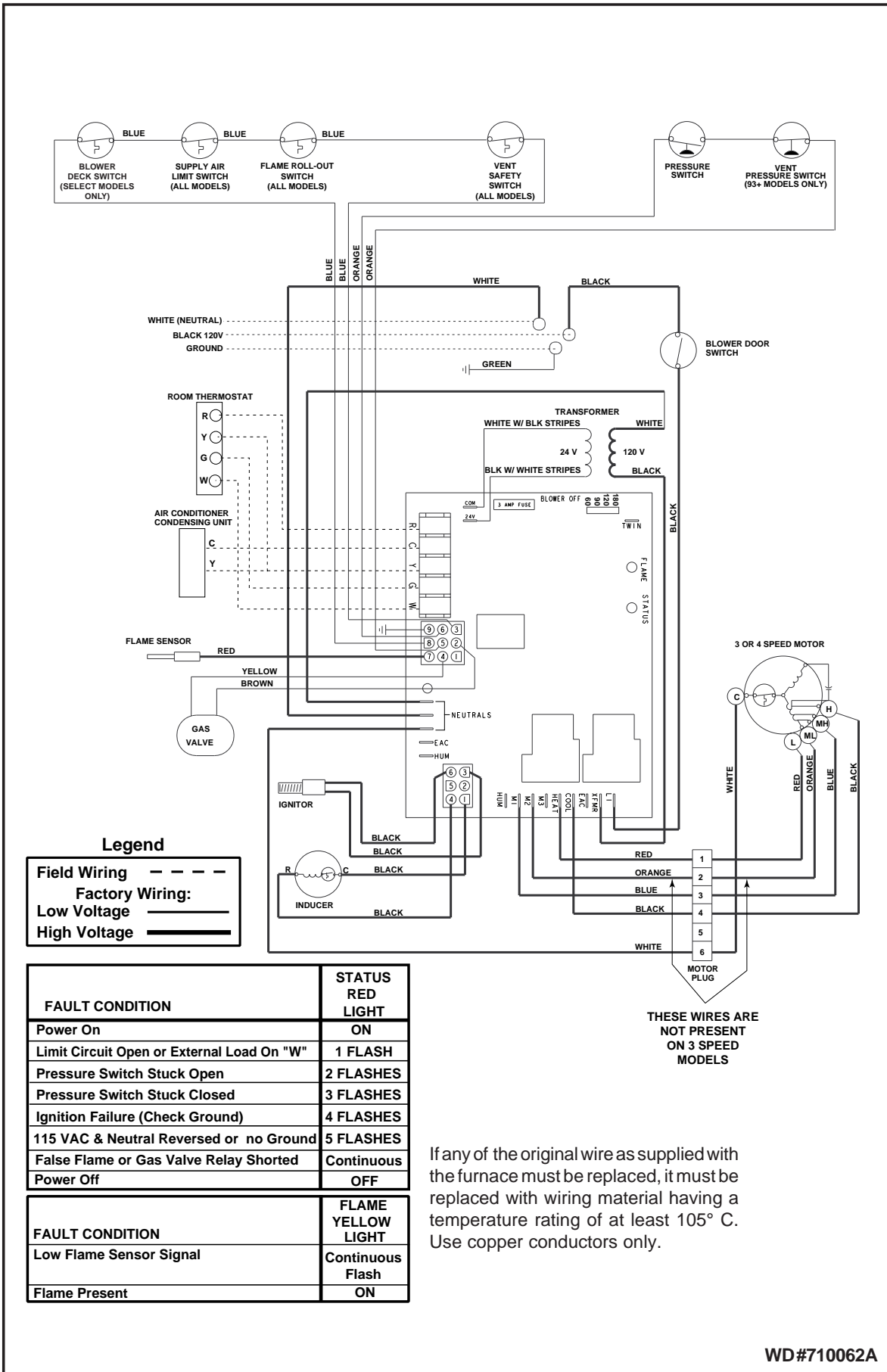

Figure 31. Upflow and Downflow Furnace Wiring Diagram

INSTALLATION/PERFORMANCE CHECKLIST

LOCATION _____ CITY _____ STATE _____

INSTALLER _____ CITY _____ STATE _____

UNIT MODEL NUMBER _____ UNIT SERIAL NUMBER _____

Minimum Clearances per Table 3? _____ Are Flue Connections tight? _____

Electrical Connections tight? _____ Is there Proper Draft? _____

Line Voltage Polarity correct? _____ Is Vent free from restrictions? _____

Supply Voltage: _____ Volts

Blower Motor HP: _____ Is the Filter(s) secured in place? _____

Is the Filter(s) clean? _____

FUEL TYPE:

Natural Gas _____ LP/Propane _____ Has the Thermostat been calibrated? _____

Gas Piping Connections leak-tested? _____ Is the Thermostat level? _____

Gas Line Pressure: _____ Is the Heat Anticipator Setting correct? _____
(in. water column, with furnace operating)

Manifold Pressure: _____

(in. water column, with furnace operating)

Is there adequate fresh air supply for combustion and ventilation? _____

Has the Owner's Information been reviewed with the home-owner? _____

Has the Literature Package been left near the furnace? _____

Furnace Input: _____ (Btuh)

Supply Air Temperature: _____ (° F)

Return Air Temperature: _____ (° F)

Temperature Rise: _____ (° F)



708120B

708120B (Replaces 708120A)

O'Fallon, MO

NORDYNE

Specifications and illustrations subject to change without
notice and without incurring obligations. Printed in U.S.A.
(04/04)