

Outdoor Heat Pump

User's Information/Installation Instructions

12 SEER High Efficiency Split System

These units have been designed and tested for capacity and efficiency in accordance with A.R.I. Standards. Split System Heat Pump units are designed for use with a wide variety of fossil fuel furnaces, electric furnaces, air handlers, and evaporator coil combinations.

These instructions are primarily intended to assist qualified individuals experienced in the proper installation of heating and/or air conditioning appliances. Some local codes require licensed installation/service personnel for this type of equipment. Read all instructions carefully before starting the installation.

USER'S INFORMATION

IMPORTANT

Read this owner information to become familiar with the capabilities and use of your appliance. Keep this with literature on other appliances where you have easy access to it in the future. If a problem occurs, check the instructions and follow recommendations given. If these suggestions don't eliminate your problem, call your servicing contractor.

Heat Pump Principle of Operation

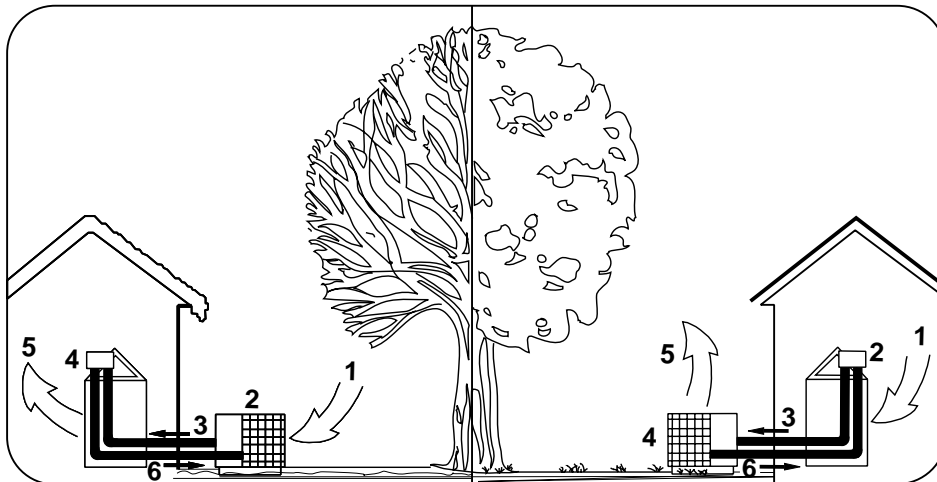

WINTER HEATING

1. Outdoor air enters heat pump.
2. Cold, heat-transfer section (outdoor coil) extracts heat from outdoor air as refrigerant evaporates from a liquid to a gas.
3. Refrigerant, compressed to a hot gas by heat pump, carries the heat to the hot heat-transfer section (indoor coil).
4. Hot, heat-transfer section (indoor coil) releases the heat to indoor air as refrigerant condenses from a gas to a liquid.
5. Air handler circulates the heat throughout the home.
6. Refrigerant returns to outdoor coil and evaporates once again to absorb more heat.

SUMMER COOLING

1. Indoor air enters the air handler section.
2. Cold, heat-transfer section (indoor coil) extracts heat from indoor air as refrigerant evaporates from a liquid to a cold gas.
3. Refrigerant, drawn to heat pump and compressed to a hot gas by heat pump, carries the heat outdoors.
4. Hot, heat-transfer section (outdoor coil) releases the heat as refrigerant condenses from a gas to a liquid.
5. Heat pump (outdoor fan) discharges the heat to outside air.
6. Refrigerant returns to indoor coil and evaporates once again to absorb more heat.

OPERATING INSTRUCTIONS

TO OPERATE YOUR HEAT PUMP FOR COOLING —

1. Set the thermostat system switch to COOL and the thermostat fan switch to AUTO. (See Figure 1)
2. Set the thermostat temperature to the desired temperature level using the temperature selector. Please refer to the separate detailed thermostat user's manual for complete instructions regarding thermostat programming. The outdoor unit and indoor blower will both cycle on and off to maintain the indoor temperature at the desired cooling level.

NOTE: If the thermostat temperature level is re-adjusted, or the thermostat system switch is repositioned, the outdoor unit may not start immediately. The outdoor unit contains a protective timer circuit which holds the unit off for approximately five minutes following a previous operation, or the interruption of the main electrical power.

TO OPERATE YOUR HEAT PUMP FOR HEATING —

1. Set the thermostat system switch to HEAT and the thermostat fan switch to AUTO. (See Figure 1)

2. Set the thermostat temperature to the desired temperature level using the temperature selector. Please refer to the separate detailed thermostat user's manual for complete instructions regarding thermostat programming. The outdoor unit and indoor blower will both cycle on and off to maintain the indoor temperature at the desired heating level.

NOTE: If the thermostat temperature level is re-adjusted, or the thermostat system switch is repositioned, the outdoor unit may not start immediately. The outdoor unit contains a protective timer circuit which holds the unit off for approximately five minutes following a previous operation, or the interruption of the main electrical power.

Emergency Heat:

The thermostat includes a system switch position termed EM. HT. This is a back-up heating mode to be used only if there is a suspected problem with the outdoor unit. With the system switch set to EM. HT. the outdoor unit will be locked off, and supplemental heat (typically electric resistance heating) will be used as a source of heat. Sustained use of electric resistance heat in place of the heat pump will result in an increase in electric utility costs.

Defrost:

During cold weather heating operation, the outdoor unit will develop a coating of

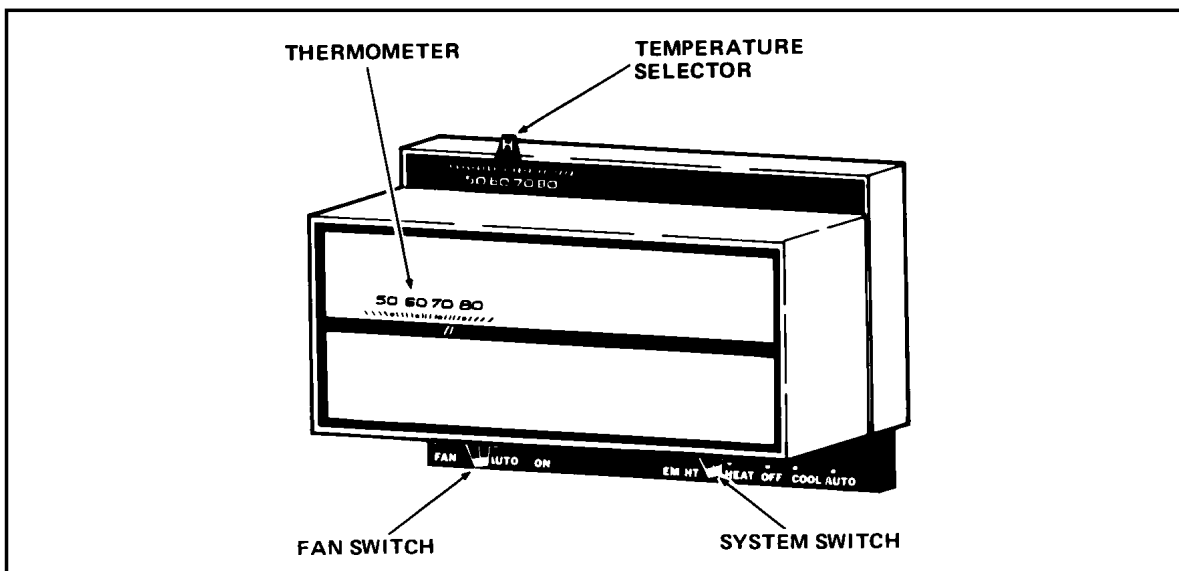

Figure 1. Typical Thermostat

snow and ice on the heat transfer coil. This is normal, and the unit will periodically defrost itself. During the defrost cycle, the outdoor fan will stop, and the compressor will continue to run and heat the outdoor coil, causing the snow and ice to melt. After the snow and ice have melted, some steam may rise from the outdoor unit as the warm coil causes some melted frost to evaporate.

TO OPERATE YOUR HEAT PUMP FOR AUTOMATIC COOLING AND HEATING

1. Set the thermostat system switch to AUTO and the thermostat fan switch to AUTO. (See Figure 1)

Note: Thermostats will vary. Some models will not include the AUTO mode, and others will have the AUTO in place of the HEAT and COOL, and some will include all three.

2. Set the thermostat temperature to the desired heating and cooling temperature level(s). The outdoor unit and the indoor blower will then cycle on and off in either the heating or cooling mode of operation as required to automatically maintain the indoor temperature within the desired limits.

TO SHUT OFF YOUR HEAT PUMP —

Set the thermostat system switch to OFF and the thermostat fan switch to AUTO. (See Figure 1) The system will not operate, regardless of the thermostat temperature selector(s) setting.

TO OPERATE THE INDOOR BLOWER CONTINUOUSLY —

Set the thermostat fan switch to ON (See Figure 1). The indoor blower will start immediately, and will run continually until the fan switch is reset to AUTO.

The continuous indoor blower operation can be obtained with the thermostat system switch set in any position, including OFF.

The continuous indoor blower operation is typically used to circulate the indoor air to equalize

a temperature unbalance due to a sun load, cooking, or fireplace operation.

TO MAINTAIN YOUR HEAT PUMP —



CAUTION:

Be certain the electrical power to the outdoor unit and the furnace/air handler is disconnected before doing the following recommended maintenance.

1. Regularly:

- a. Clean or replace the indoor air filter at the start of each heating and cooling season, and when an accumulation of dust and dirt is visible on the air filter. Inspect the filter monthly.
- b. Remove any leaves and grass clippings from the coil in the outdoor unit, being careful not to damage the aluminum fins.
- c. Check for any obstruction such as twigs, sticks, etc.



CAUTION:

Do not over-oil, or oil motors not factory-equipped with oil tubes. The compressor is hermetically “sealed” and does not require lubrication.

2. Before Calling a Service Technician, Be Certain:

- a. The unit thermostat is properly set — see “To Operate Your Heat Pump for Cooling” and “To Operate Your Heat Pump for Heating.”
- b. The unit disconnect fuses are in good condition, and the electrical power to the unit is turned on.

Read Your Warranty

Please read the separate warranty document completely. It contains valuable information about your system.

GENERAL INFORMATION

Read the following instructions completely before performing the installation.

Outdoor Unit Section — Each outdoor unit is shipped with a refrigerant charge adequate to operate the outdoor section with an indoor matching coil or air handler. Units with braze connections include the proper amount of refrigerant for an additional 15 ft. of refrigerant lines the same size as the valve fittings.

NOTE: DO NOT USE ANY PORTION OF THE CHARGE FOR PURGING OR LEAK TESTING.

Matching coils and air handlers may be shipped with a small holding charge to pressurize them to keep out contaminants. To release the pressure, read the indoor section installation instructions carefully.

Liquid and Suction Lines — Fully annealed, refrigerant grade copper tubing should be used when installing the system. Refrigerant suction line tubing should be fully insulated.

Field Connections for Electrical Power Supply — All wiring must comply with current provisions of the “National Electrical Code” (ANSI C1.) and with applicable local codes having jurisdiction. The minimum size of electrical conductors and circuit protection must be in compliance with information listed on the outdoor unit data label.

SAFETY CONSIDERATIONS

Pressures within the System — Split system heat pump equipment contains liquid and gaseous refrigerant under pressure. Installation and servicing of this equipment should be accomplished by qualified, trained personnel thoroughly familiar with this type of equipment. Under no circumstances should the Homeowner attempt to install and/or service the equipment.

Labels, Tags, Precautions — When working with this equipment, follow all precautions in the literature, on tags, and on labels provided with the equipment. Read and thoroughly understand the instructions provided with the equipment prior to performing the installation and operational checkout of the equipment.

Brazing Operations — Installation of equipment may require brazing operations. Safety codes must be complied with. Safety equipment (e.g.; safety glasses, work gloves, fire extinguisher, etc.) must be used when performing brazing operations.



WARNING:

Ensure all electrical power to the unit is off prior to installing or servicing the equipment. Failure to do so may cause personal injury or death.

SITE PREPARATION

Unpacking Equipment — Remove the cardboard carton and User's Manual from the equipment. Take care to not damage tubing connections when removing from the carton.

Inspect for Damage — Inspect the equipment for damage prior to installing the equipment at the job site. Ensure coil fins are straight and, if necessary, comb fins to remove flattened and bent fins.

Preferred Location of the Outdoor Unit at the Job Site — Conduct a survey of the job site to determine the optimum location for mounting the outdoor unit. Overhead obstructions, poorly ventilated areas, and areas subject to accumulation of debris should be avoided. The outdoor unit must be installed in such a manner that airflow through the coil is not obstructed and that the unit can be serviced.

Facility Prerequisites — Electrical power supplied must be adequate for proper operation of the equipment. The system must be wired and provided with circuit protection in accordance with local building codes and the National Electrical Code.

INSTALLING THE OUTDOOR UNIT

Slab Mount — The site selected for a slab mount installation requires a stable foundation and one not subject to erosion. The slab should be level and anchored (if necessary) prior to placing the equipment on the slab.

Cantilever Mount — The cantilever mount should be designed with adequate safety factor to support the weight of the equipment, and for loads subjected to the mount during operation. Installed equipment should be adequately secured to the cantilever mount and levelled prior to operation of the equipment.

Roof Mount — The method of mounting should be designed so as not to overload roof structures nor transmit noise to the interior of the structure. Refrigerant and electrical line should be routed through suitably waterproofed openings to prevent water leaking into the structure.

INSTALLING THE INDOOR UNIT

The indoor section should be installed before proceeding with routing of refrigerant piping. Consult the Installation Instructions of the indoor unit (i.e.: air handler, furnace, etc.) for details regarding installation.

CONNECTING REFRIGERANT TUBING BETWEEN THE INDOOR AND OUTDOOR UNIT

General — Once outdoor and indoor unit placement has been determined, route refrigerant tubing between the equipment in accordance with sound installation practices. Refrigerant tubing should be routed in a manner that minimizes the length of tubing and the number of bends in the tubing. Refrigerant tubing should be supported in a manner that the tubing will not vibrate or abrade during system operation. Tubing should be kept clean of foreign debris during installation and installation of a liquid line filter drier is recommended if cleanliness or adequacy of system evacuation is unknown or compromised. Every effort should be made by the installer to ensure that the field installed, refrigerant containing components of the system have been installed in accordance with these instructions and sound installation practices so as to insure reliable system operation and longevity.

The maximum recommended interconnecting refrigerant line length is 75 feet, and the vertical elevation difference between the indoor and outdoor sections should not exceed 20 feet. Consult long line application guide for installations in excess of these limits.

Filter Dryer Installation — A filter dryer is provided with PS series models only and must be installed in the liquid line of the system. If the installation replaces a system with a filter dryer already present in the liquid line, the filter dryer must be replaced with the one supplied with the unit. The filter dryer must be installed in strict accordance with the manufacturer's installation instructions.

For all other series models, installing a filter dryer is optional. However, it is good installation practice to install a filter dryer when replacing the evaporator and/or condenser of a system. When installing, the filter dryer must be installed in strict accordance with the manufacturer's installation instructions.

Optional Equipment — Optional equipment (e.g.: liquid line solenoid valves, etc.) should be installed in strict accordance with the manufacturer's installation instructions.

For refrigerant line sets that incorporate single shot couplings only:

1. Remove protective caps from the unit and the refrigerant line couplings.
2. Carefully wipe all coupling threads and seals with a clean cloth to remove any dust or foreign material which could contaminate the refrigerant system.
3. Using refrigerant oil, lightly lubricate the diaphragm, seal and threads on the male unit coupling.
4. Connect couplings as follows:

Note: Start with indoor section first.

- a. HOLD REFRIGERANT LINE IN STRAIGHT POSITION TO UNIT COUPLING AND THREAD COUPLING HALVES TOGETHER BY HAND TO INSURE PROPER CONNECTION. Hold body of the line coupling hex with wrench, while slowly tightening the union nut until a definite resistance (bottoming out) is felt.
- b. Mark the position of union nut (match lines on the line coupling and the unit bulk head), and then tighten the coupling an additional 1/4 turn to insure leak-proof connection. (See Table of Torque Values for recommended torque values if a torque wrench is used.)

TABLE OF TORQUE VALUES

Coupling Size	Torque
3/8" (10 mm) Liquid Line Coupling	10 - 12 ft. lbs. (Metric: 14-16 N-m)
3/4" (19 mm) or 7/8" (22 mm) Vapor Line Coupling	34 - 45 ft. lbs. (Metric: 47-61 N-m)
Service Valve Cap	5 - 6 ft. lbs. (Metric: 7 - 8 N-m)

ELECTRICAL CONNECTIONS

WARNING:

Turn off all electrical power at the main circuit box before wiring electrical power to the outdoor unit. Failure to comply may cause severe personnel injury or death.

Wiring Diagram/Schematic — A wiring diagram/schematic is located on the inside cover of the electrical box of the outdoor unit. The installer should become familiar with the wiring diagram/schematic before making any electrical connections to the outdoor unit.

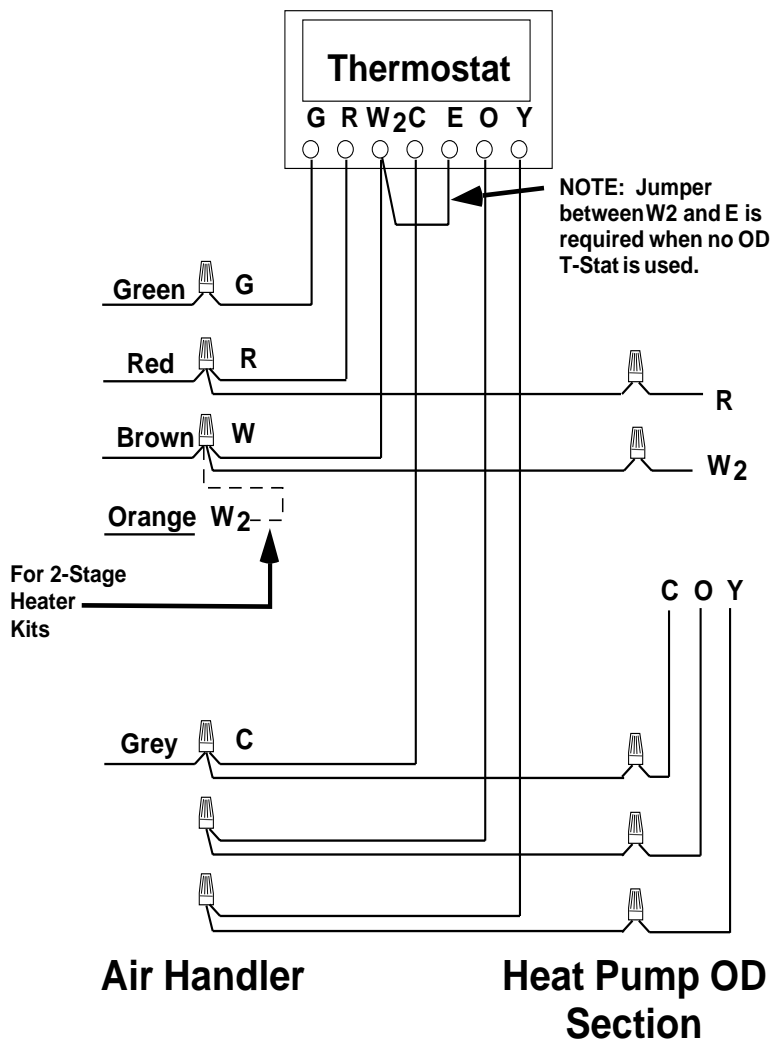

Typical Heat Pump with Standard Air Handler

A typical installation with a heat pump thermostat, air handler, and heat pump with an outdoor thermostat.

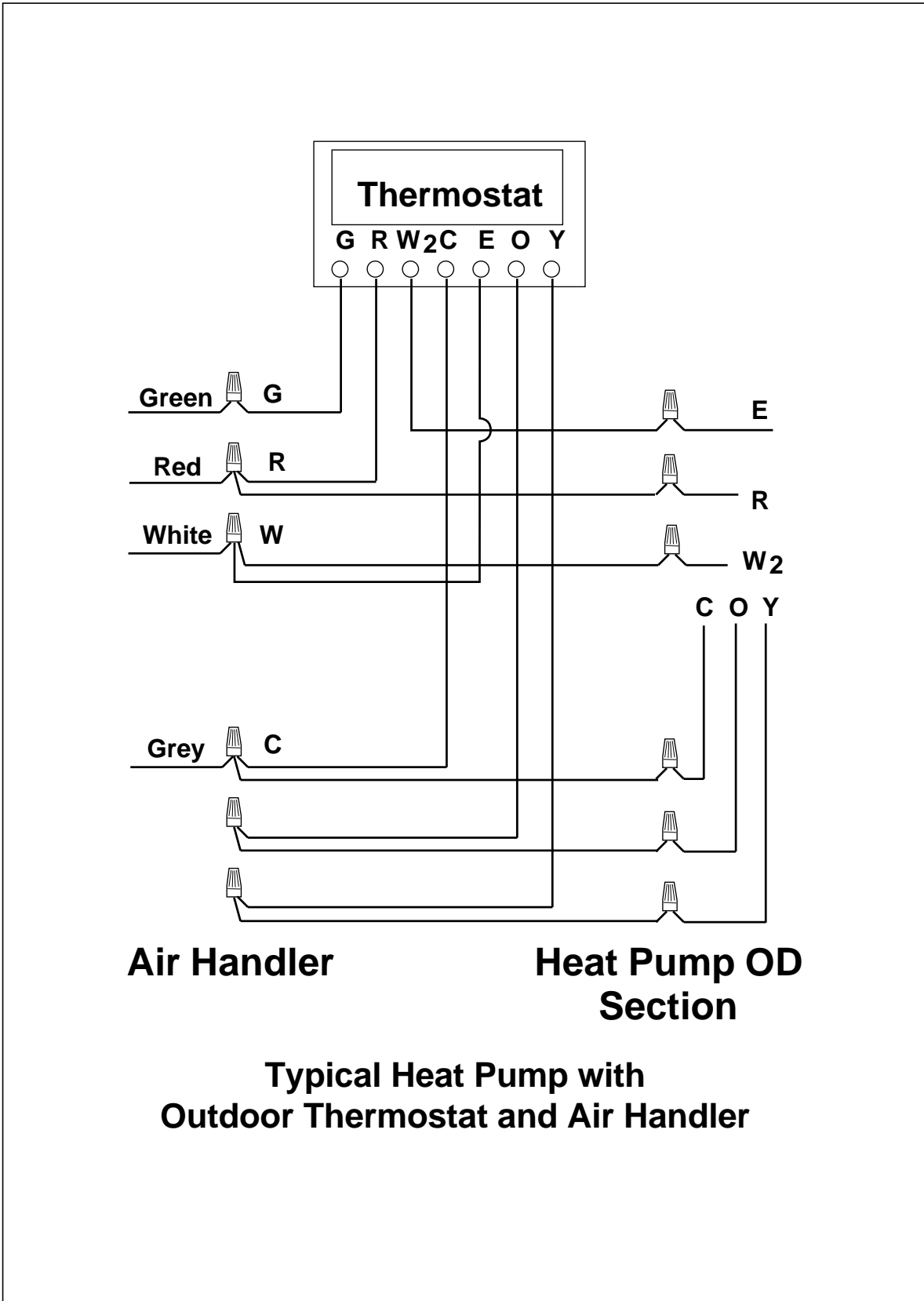

Outdoor Unit Connections — The outdoor unit requires both power and control circuit electrical connections. Refer to the unit wiring diagram/schematic for identification and location of outdoor unit field wiring interfaces.

Control Circuit Wiring — The outdoor unit is designed to operate from a 24 VAC Class II control circuit. Control circuit wiring must comply with the current provisions of the “National Electrical Code” (ANSI/NFPA 70) and with applicable local codes having jurisdiction.

Thermostat connections should be made in accordance with the instructions supplied with the thermostat, and with the instructions supplied with the indoor equipment. A typical residential installation with a heat pump thermostat and air handler are shown below.

Electrical Power Wiring — Electrical power wiring must comply with the current provisions of the “National Electrical Code” (ANSI/NFPA 70) and with applicable local codes having jurisdiction. Use of rain tight conduit is recommended. Electrical conductors shall have minimum circuit ampacity in compliance with the outdoor unit rating label. The facility shall employ electrical circuit protection at a current rating no greater than that indicated on the outdoor unit rating label. Refer to the unit wiring diagram for connection details.

Minimum Circuit Ampacity — Electrical wiring to the equipment must be compatible and in

COPPER WIRE SIZE — AWG (1% Voltage Drop)				
Supply Wire Length-Feet				Supply Circuit
200	150	100	50	Ampacity
6	8	10	14	15
4	6	8	12	20
4	6	8	10	25
4	4	6	10	30
3	4	6	8	35
3	4	6	8	40
2	3	4	6	45
2	3	4	6	50

Wire Size based on N.E.C. for 60° type copper conductors.

compliance with the minimum circuit ampacity listed on the outdoor unit data label.

Maximum Fuse/Circuit Breaker Size — Circuit protection for the outdoor unit must be compatible with the maximum fuse/circuit breaker size listed on the outdoor unit data label.

Disconnect Switch — An electrically compatible disconnect switch must be within line of sight of the outdoor unit. This switch shall be capable of electrically de-energizing the outdoor unit.

Optional Equipment — Optional equipment requiring connection to the power or control circuits must be wired in strict accordance with current provisions of the “National Electrical Code” (ANSI/NFPA 70), with applicable local codes having jurisdiction, and the installation instructions provided with the equipment. Optional Equipment (e.g.: liquid line solenoid valves, hard start kits, low suction pressure cutout switch kit, high pressure cutout switch kit, refrigerant compressor crankcase heater, etc.) should be installed in strict accordance with the manufacturer’s installation instructions.

STARTUP AND CHECKOUT



WARNING:

Ensure electrical power to the unit is off prior to performing the following steps. Failure to do so may cause personal injury or death.

Air Filters — Ensure air filters are clean and in place prior to operating the equipment.

Thermostat — Set the room thermostat function switch to OFF, fan switch to AUTO, and adjust the temperature setpoint to its highest setting.

Prior to applying electrical power to the outdoor unit, ensure that the unit has been properly and securely grounded, and that power supply

connections have been made at both the facility power interface and outdoor unit.

Outdoor Unit — Ensure the outdoor coil and top of the unit are free from obstructions and debris, and all equipment access/control panels are in place.

Using extreme caution, apply power to the unit and inspect the wiring for evidence of open, shorted, and/or improperly wired circuits.

Functional Checkout:

CAUTION:

If equipped with a compressor crankcase heater, wait 24 hours prior to performing a function checkout to allow for heating of the compressor crankcase. Failure to comply may result in damage and could cause premature failure of the system.

Indoor Blower — Set the thermostat function switch to COOLING and the fan switch to ON. Verify that the indoor blower is operating and that airflow is not restricted. Set the fan switch back to AUTO.

Low-Pressure Switch — A low-pressure switch is factory-installed in select models only. If provided, this switch is located in the suction line internal to the outdoor unit. The switch is designed to protect the compressor from a loss of charge. Under normal conditions, the switch is closed. If the suction pressure falls below 5 psig, then the switch will open and de-energize the outdoor unit. The switch will close again once the suction pressure increases above 20 psig. Please note that the switch interrupts the thermostat inputs to the unit. Thus, when the switch opens and then closes, there will be a 5 minute short cycling delay before the outdoor unit will energize.

Cooling — Gradually lower the thermostat temperature setpoint below the actual room temperature and observe that the outdoor unit and indoor blower energize. Feel the air being circulated by the indoor blower and verify that it is cooler than ambient temperature. Listen for any unusual noises. If present, locate and determine the source of the noise and correct as necessary.

Short Cycle Protection — With the system operating in COOLING mode, note the setpoint temperature setting of the thermostat, and gradually raise the setpoint temperature until the outdoor unit and indoor blower de-energize. Immediately lower the setpoint temperature of the thermostat to its original setting and verify that the indoor blower is energized and that the outdoor unit remains de-energized. Verify that, after approximately 5 minutes, the outdoor unit energizes and that the temperature of the air supplied to the facility is cooler than ambient temperature.

Heating — Lower the thermostat setpoint temperature to the lowest obtainable setting and set the thermostat function switch to HEATING. The indoor blower and outdoor unit should stop running. After a minimum of five minutes, increase the setpoint temperature of the thermostat to the maximum setting. Verify that the outdoor unit and indoor blower have energized. Feel the air being circulated by the indoor blower and verify that it is warmer than ambient temperature. Listen for any unusual noises. If present, locate and determine the source of the noise and correct as necessary.

OUTDOOR THERMOSTAT (if supplied)

The outdoor thermostat prevents the electrical auxiliary heat (if used) from operating when the outdoor temperature is above 40°F.

Defrost Cycle Timer — The defrost cycle timer controls the time interval of the hot gas defrost after the defrost sensor closes. It is located in the lower left corner of the defrost control board. Three interval settings are available: 30 minutes, 60 minutes, and 90 minutes. Time setting selection is dependent on the climate where the unit is being installed.

Example 1. Dry climate of Southern Arizona. A 90 minute setting is recommended.

Example 2. Moist climate of Seattle, Washington. A 30 minute setting is recommended.

To set the cycle timer, place the timing pin on the defrost control board to the desired time interval post.

Note: All units are shipped from the factory with the default time setting of 30 minutes. Maximum heating performance can be achieved by setting the time to 90 minutes.

Defrost Test Procedure

1. Terminals “R”-“C” must have 18-30v present between them in order for time delay and defrost sequences to be initiated.
2. With compressor running in heat mode, first jump the “T2”-“DFT” test pins. This will indicate to board that defrost T-stat is closed. Defrost T-stat closes at 32°, opens at 68°.
3. Next jump the “Test” pin to “C” on terminal strip. This will initiate defrost test in 5, 10 or 15 seconds (This is determined by 30, 60 or 90 minutes defrost pin settings). Factory setting will be 30 minutes.
4. When the reversing valve shifts to the defrost mode, quickly remove jumper from “Test”-“C”. If the jumper is not removed within a 5 second period, the defrost test will terminate. Unit will continue to stay in defrost mode Until :
 - A) Board recognizes that defrost sensor has reached 68° and opened or
 - B) “T2”-“DFT” jumper is removed or
 - C) 10 minutes have elapsed (board override)

If the above steps will not initiate a defrost, replace the defrost board.

Anti Short Cycle Timer Test

The 5 minute time delay feature can be bypassed or shortened to 1 second by jumping the “Test” to “C” terminal.

Note: If jumper is left on the “Test” to “common” pins permanently, the defrost cycle will become inoperable.

Optional Equipment — A functional checkout should be performed in accordance with the checkout procedures supplied with the equipment.

Adjustment of Refrigerant Charge:

! CAUTION:

Split system heat pump equipment contains liquid and gaseous refrigerant under pressure. Adjustment of refrigerant charge should only be attempted by qualified, trained personnel thoroughly familiar with the equipment. Under no circumstances should the homeowner attempt to install and/or service this equipment. Failure to comply with this warning could result in equipment damage, personal injury, or death.

NOTE: The following Refrigerant Charging Charts are applicable to listed assemblies of equipment and at listed airflows for the indoor coil. Assemblies of indoor coils and outdoor units not listed are not recommended.

12 SEER SPLIT SYSTEM HEAT PUMP ORIFICE USAGE

Model Number	Restrictor Bore Size (in.)		System Charge R-22 (oz.)
	Indoor	Outdoor	
1-1/2 Ton	.053	.043	72
2 Ton	.065	.047	112
2-1/2 Ton	.067	.051	133
3 Ton	.077	.055	146
3-1/2 Ton	.085	.061	162
4 Ton	.093	.065	240
5 Ton	.099	.071	264

REFRIGERANT CHARGING CHARTS FOR COOLING MODE OF OPERATION

12 SEER Split System Heat Pump Charging Charts for Cooling Cycle

- Shaded Boxes indicate flooded conditions
 - Bold Outlined Boxes indicate Rated Design Values.
 Suction Pressure will be lower than design value if indoor air flow, entering dry bulb, or entering wet bulb temperatures are lower than design.
 - Discharge temperatures greater than charted values indicate a refrigerant undercharge.

1-1/2 TON	OUTDOOR TEMPERATURE (°F)															
	70		75		80		85		90		95		100		105	
	Liquid Press.	Disch. Temp.	Liquid Press.	Disch. Temp.	Liquid Press.	Disch. Temp.	Liquid Press.	Disch. Temp.	Liquid Press.	Disch. Temp.	Liquid Press.	Disch. Temp.	Liquid Press.	Disch. Temp.	Liquid Press.	Disch. Temp.
74	161	157														
76	163	162	177	173												
78	166	167	179	178	193	190										
80	168	171	181	183	195	195	209	207								
82	172	174	184	187	197	200	211	211	224	223						
84			188	190	200	203	213	216	226	227	240	239				
86					204	207	216	220	228	232	242	244	256	256		
88							219	223	232	236	244	248	258	260	272	272
90							223	227	235	240	248	252	260	264	274	276
92									239	243	251	256	263	268	276	280
94											254	260	267	272	279	284
96													270	277	283	289
98																
100															286	293

2 TON	OUTDOOR TEMPERATURE (°F)															
	70		75		80		85		90		95		100		105	
	Liquid Press.	Disch. Temp.	Liquid Press.	Disch. Temp.	Liquid Press.	Disch. Temp.	Liquid Press.	Disch. Temp.	Liquid Press.	Disch. Temp.	Liquid Press.	Disch. Temp.	Liquid Press.	Disch. Temp.	Liquid Press.	Disch. Temp.
70	136	120														
72	137	132	149	126												
74	139	143	151	136	162	131										
76	140	155	153	146	165	139	176	135								
78	140	176	155	156	168	148	179	143	190	138						
80			156	174	170	160	183	151	194	146	204	142				
82					171	173	185	162	197	153	208	148	218	145		
84							186	173	199	163	212	155	222	151	232	148
86									202	174	214	165	227	157	237	154
88											217	175	229	167	242	159
90											219	185	232	176	244	169
92													234	185	246	177
94															249	186

*Note: All pressures are listed in psig, and all temperatures in degrees F.

REFRIGERANT CHARGING CHARTS FOR COOLING MODE OF OPERATION - Continued

12 SEER Split System Heat Pump Charging Charts for Cooling Cycle

- Shaded Boxes indicate flooded conditions
 - Bold Outlined Boxes indicate Rated Design Values.
 Suction Pressure will be lower than design value if indoor air flow, entering dry bulb, or entering wet bulb temperatures are lower than design.
 - Discharge temperatures greater than charted values indicate a refrigerant undercharge.

2-1/2 TON	OUTDOOR TEMPERATURE (°F)															
	70		75		80		85		90		95		100		105	
	Liquid Press.	Disch. Temp.	Liquid Press.	Disch. Temp.	Liquid Press.	Disch. Temp.	Liquid Press.	Disch. Temp.	Liquid Press.	Disch. Temp.	Liquid Press.	Disch. Temp.	Liquid Press.	Disch. Temp.	Liquid Press.	Disch. Temp.
68	142	124														
70	143	136	155	130												
72	145	147	157	140	169	135										
74	146	159	160	150	172	143	183	139								
76	146	180	162	160	175	152	186	147	197	142						
78			162	178	176	164	190	155	201	150	212	146				
80					178	177	192	166	205	157	216	152	226	149		
82							194	177	207	167	220	159	231	155	241	152
84									209	178	222	169	235	161	246	158
86											225	179	237	171	250	163
88											227	189	240	180	253	173
90													242	189	255	181
92															258	190
94																

3 TON	OUTDOOR TEMPERATURE (°F)															
	70		75		80		85		90		95		100		105	
	Liquid Press.	Disch. Temp.	Liquid Press.	Disch. Temp.	Liquid Press.	Disch. Temp.	Liquid Press.	Disch. Temp.	Liquid Press.	Disch. Temp.	Liquid Press.	Disch. Temp.	Liquid Press.	Disch. Temp.	Liquid Press.	Disch. Temp.
67	147	122														
69	148	134	159	130												
71	149	145	161	140	173	137										
73	151	156	164	150	175	146	187	142								
75	151	173	166	160	178	154	190	150	201	147						
77			167	175	181	164	193	158	205	154	216	151				
79					182	177	196	168	209	161	220	157	231	154		
81							198	179	211	171	224	164	235	160	246	158
83									213	182	226	174	240	167	251	163
85											229	184	242	177	255	169
87											231	194	244	186	257	179
89													246	195	259	188
91															262	197
93																

*Note: All pressures are listed in psig, and all temperatures in degrees F.

REFRIGERANT CHARGING CHARTS FOR COOLING MODE OF OPERATION - Continued

12 SEER Split System Heat Pump Charging Charts for Cooling Cycle

- Shaded Boxes indicate flooded conditions
 - Bold Outlined Boxes indicate Rated Design Values.
 Suction Pressure will be lower than design value if indoor air flow, entering dry bulb, or entering wet bulb temperatures are lower than design.
 - Discharge temperatures greater than charted values indicate a refrigerant undercharge.

3-1/2 TON	OUTDOOR TEMPERATURE (°F)															
	70		75		80		85		90		95		100		105	
	Liquid Press.	Disch. Temp.	Liquid Press.	Disch. Temp.	Liquid Press.	Disch. Temp.	Liquid Press.	Disch. Temp.	Liquid Press.	Disch. Temp.	Liquid Press.	Disch. Temp.	Liquid Press.	Disch. Temp.	Liquid Press.	Disch. Temp.
68	147	139														
70	148	151	161	143												
72	150	162	163	153	175	146										
74	151	173	165	163	178	155	149									
76	151	195	167	173	181	164	157	204	151							
78			168	191	182	176	165	208	158	219	153					
80			184	189	184	189	176	211	165	223	159	234	154			
82							200	214	176	227	166	238	160	249	156	
84								216	186	229	176	243	167	254	162	
86										232	186	245	176	258	167	
88										234	196	247	186	260	176	
90												250	195	263	185	
92														265	194	
94																

4 TON	OUTDOOR TEMPERATURE (°F)															
	70		75		80		85		90		95		100		105	
	Liquid Press.	Disch. Temp.	Liquid Press.	Disch. Temp.	Liquid Press.	Disch. Temp.	Liquid Press.	Disch. Temp.	Liquid Press.	Disch. Temp.	Liquid Press.	Disch. Temp.	Liquid Press.	Disch. Temp.	Liquid Press.	Disch. Temp.
67	141	130														
69	142	142	155	135												
71	144	153	157	145	169	140										
73	145	164	159	155	172	149	183	143								
75	145	186	161	165	175	157	187	151	198	147						
77			162	183	176	170	190	159	202	154	213	150				
79					178	182	192	170	205	161	217	156	228	153		
81							194	182	208	172	221	163	232	159	243	155
83									210	182	223	173	237	165	248	161
85											226	183	239	174	252	167
87											228	193	241	184	254	176
89													244	193	257	185
91															259	194
93																

*Note: All pressures are listed in psig, and all temperatures in degrees F.

REFRIGERANT CHARGING CHARTS FOR COOLING MODE OF OPERATION - Continued

12 SEER Split System Heat Pump Charging Charts for Cooling Cycle

- Shaded Boxes indicate flooded conditions

- Bold Outlined Boxes indicate Rated Design Values.

Suction Pressure will be lower than design value if indoor air flow, entering dry bulb, or entering wet bulb temperatures are lower than design.

- Discharge temperatures greater than charted values indicate a refrigerant undercharge.

5 TON	OUTDOOR TEMPERATURE (°F)																	
	70		75		80		85		90		95		100		105			
	Liquid Press.	Disch. Temp.	Liquid Press.	Disch. Temp.	Liquid Press.	Disch. Temp.	Liquid Press.	Disch. Temp.	Liquid Press.	Disch. Temp.	Liquid Press.	Disch. Temp.	Liquid Press.	Disch. Temp.	Liquid Press.	Disch. Temp.		
64	138	133																
66	140	144	153	138														
68	141	155	155	148	168	143												
70	142	167	158	158	171	152	184	148										
72	142	188	160	168	174	161	187	156	200	152								
74			160	186	176	173	191	164	204	159	216	156						
76					177	186	193	175	207	166	220	162	232	159				
78						195	186	186	210	177	224	169	236	165	248	163		
80									212	187	226	179	241	172	253	168		
82											229	189	243	181	257	174		
84											231	199	245	190	260	183		
86													248	200	262	192		
88															265	201		
90																		

*Note: All pressures are listed in psig. and all temperatures in degrees F.

REFRIGERANT CHARGING CHARTS FOR HEATING MODE OF OPERATION 12 SEER Split System Heating Charts

- Shaded Boxes indicate flooded conditions
 - Bold Outlined Boxes indicate Rated Design Values.
 Suction Pressure will be lower than design value if indoor air flow, entering dry bulb, or entering wet bulb temperatures are lower than design.
 - Discharge temperatures greater than charted values indicate a refrigerant undercharge.

1-1/2 TON																				
OUTDOOR TEMPERATURE (°F)																				
		10			20			30			40			50			60			
S.P.	L.P.	D.T.	S.P.	L.P.	D.T.	S.P.	L.P.	D.T.	S.P.	L.P.	D.T.	S.P.	L.P.	D.T.	S.P.	L.P.	D.T.	S.P.	L.P.	D.T.
14	116	105	23	130	111	31	145	116	40	160	122	48	162	137	58	175	161	67	188	185
15	123	103	24	136	109	32	150	114	41	163	120	49	169	134	59	182	157	68	195	179
16	130	101	25	142	107	33	155	112	42	167	118	50	176	131	60	189	152	69	202	173
17	137	99	26	148	105	34	160	110	43	171	116	51	183	128	61	196	148	70	209	167
18	144	97	27	154	103	35	164	108	44	175	114	52	190	125	62	203	143	71	216	161
19	151	95	28	160	101	36	169	106	45	178	112	53	197	123	63	210	139	72	223	155
20	158	93	29	166	99	37	174	104	46	182	110	54	204	120	64	217	134	73	230	148

2 TON																				
OUTDOOR TEMPERATURE (°F)																				
		10			20			30			40			50			60			
S.P.	L.P.	D.T.	S.P.	L.P.	D.T.	S.P.	L.P.	D.T.	S.P.	L.P.	D.T.	S.P.	L.P.	D.T.	S.P.	L.P.	D.T.	S.P.	L.P.	D.T.
15	119	121	22	137	125	29	155	128	36	173	131	46	180	147	59	201	175	71	222	204
16	126	119	23	143	123	30	160	126	37	176	129	47	187	144	60	208	171	72	229	198
17	133	117	24	149	121	31	165	124	38	180	127	48	194	141	61	215	166	73	236	191
18	140	115	25	155	119	32	169	122	39	184	125	49	201	139	62	222	162	74	243	185
19	147	113	26	161	117	33	174	120	40	187	123	50	208	136	63	229	158	75	250	179
20	154	111	27	167	115	34	179	118	41	191	121	51	215	133	64	236	153	76	257	173
21	161	109	28	173	113	35	184	116	42	195	119	52	222	130	65	243	149	77	264	167

2-1/2 TON																				
OUTDOOR TEMPERATURE (°F)																				
		10			20			30			40			50			60			
S.P.	L.P.	D.T.	S.P.	L.P.	D.T.	S.P.	L.P.	D.T.	S.P.	L.P.	D.T.	S.P.	L.P.	D.T.	S.P.	L.P.	D.T.	S.P.	L.P.	D.T.
14	119	116	23	140	123	32	161	130	41	182	137	50	192	155	61	214	182	72	235	210
15	126	114	24	146	121	33	166	128	42	186	135	51	199	152	62	221	178	73	242	204
16	133	112	25	152	119	34	171	126	43	189	133	52	206	149	63	228	173	74	249	197
17	140	110	26	158	117	35	175	124	44	193	131	53	213	146	64	235	169	75	256	191
18	147	108	27	163	115	36	180	122	45	197	129	54	220	143	65	242	164	76	263	185
19	154	106	28	169	113	37	185	120	46	200	127	55	227	141	66	249	160	77	270	179
20	161	104	29	175	111	38	190	118	47	204	125	56	234	138	67	256	155	78	277	173

*Note: All pressures are listed in psig, and all temperatures in degrees F.

REFRIGERANT CHARGING CHARTS FOR HEATING MODE OF OPERATION - Continued

12 SEER Split System Heating Charts

- Shaded Boxes indicate flooded conditions
 - Bold Outlined Boxes indicate Rated Design Values.
 Suction Pressure will be lower than design value if indoor air flow, entering dry bulb, or entering wet bulb temperatures are lower than design.
 Discharge temperatures greater than charted values indicate a refrigerant undercharge.

3 TON		OUTDOOR TEMPERATURE (°F)																					
		0			10			20			30			40			50			60			
		S.P.	L.P.	D.T.	S.P.	L.P.	D.T.	S.P.	L.P.	D.T.	S.P.	L.P.	D.T.	S.P.	L.P.	D.T.	S.P.	L.P.	D.T.	S.P.	L.P.	D.T.	
12	115	130	20	135	134	27	156	138	35	176	142	44	187	161	55	210	195	66	233	229			
13	122	128	21	141	132	28	161	136	36	180	140	45	194	158	56	217	191	67	240	223			
14	129	126	22	147	130	29	165	134	37	184	138	46	201	155	57	224	186	68	247	217			
15	136	124	23	153	128	30	170	132	38	187	136	47	208	153	58	231	182	69	254	211			
16	143	122	24	159	126	31	175	130	39	191	134	48	215	150	59	238	177	70	261	205			
17	150	120	25	165	124	32	180	128	40	195	132	49	222	147	60	245	173	71	268	199			
18	157	118	26	171	122	33	185	126	41	198	130	50	229	144	61	252	168	72	275	192			

3-1/2 TON		OUTDOOR TEMPERATURE (°F)																					
		0			10			20			30			40			50			60			
		S.P.	L.P.	D.T.	S.P.	L.P.	D.T.	S.P.	L.P.	D.T.	S.P.	L.P.	D.T.	S.P.	L.P.	D.T.	S.P.	L.P.	D.T.	S.P.	L.P.	D.T.	
15	121	124	22	139	128	29	157	131	36	175	134	45	182	152	55	199	183	65	217	215			
16	128	122	23	145	126	30	162	129	37	179	132	46	189	149	56	206	179	66	224	209			
17	135	120	24	151	124	31	167	127	38	183	130	47	196	146	57	213	174	67	231	203			
18	142	118	25	157	122	32	172	125	39	187	128	48	203	143	58	220	170	68	238	197			
19	149	116	26	162	120	33	176	123	40	190	126	49	210	141	59	227	166	69	245	191			
20	156	114	27	168	118	34	181	121	41	194	124	50	217	138	60	234	161	70	252	184			
21	163	112	28	174	116	35	186	119	42	198	122	51	224	135	61	241	157	71	259	178			

4 TON		OUTDOOR TEMPERATURE (°F)																					
		0			10			20			30			40			50			60			
		S.P.	L.P.	D.T.	S.P.	L.P.	D.T.	S.P.	L.P.	D.T.	S.P.	L.P.	D.T.	S.P.	L.P.	D.T.	S.P.	L.P.	D.T.	S.P.	L.P.	D.T.	
13	114	120	21	140	126	30	165	133	38	191	140	47	207	156	57	237	183	67	267	210			
14	121	118	22	146	124	31	170	131	39	195	138	48	214	153	58	244	178	68	274	203			
15	128	116	23	152	122	32	175	129	40	198	136	49	221	151	59	251	174	69	281	197			
16	135	114	24	157	120	33	180	127	41	202	134	50	228	148	60	258	170	70	288	191			
17	142	112	25	163	118	34	184	125	42	206	132	51	235	145	61	265	165	71	295	185			
18	149	110	26	169	116	35	189	123	43	209	130	52	242	142	62	272	161	72	302	179			
19	156	108	27	175	114	36	194	121	44	213	128	53	249	139	63	279	156	73	309	173			

*Note: All pressures are listed in psig, and all temperatures in degrees F.

REFRIGERANT CHARGING CHARTS FOR HEATING MODE OF OPERATION - Continued

12 SEER Split System Heating Charts

5 TON		OUTDOOR TEMPERATURE (°F)																																																																																																																																																																																										
		0						10						20						30						40						50						60																																																																																																																																																						
		S.P.	L.P.	D.T.	S.P.	L.P.	D.T.	S.P.	L.P.	D.T.	S.P.	L.P.	D.T.	S.P.	L.P.	D.T.	S.P.	L.P.	D.T.	S.P.	L.P.	D.T.	S.P.	L.P.	D.T.	S.P.	L.P.	D.T.	S.P.	L.P.	D.T.	S.P.	L.P.	D.T.	S.P.	L.P.	D.T.																																																																																																																																																							
13	116	103	21	144	125	125	30	173	148	148	38	202	170	170	47	220	191	191	56	251	210	210	65	282	229	229	14	123	101	22	150	123	123	31	178	146	146	39	206	168	168	48	227	188	188	57	258	205	205	66	289	223	223	15	130	99	23	156	121	121	32	183	144	144	40	210	166	166	49	234	185	185	58	265	201	201	67	296	217	217	16	137	97	24	162	119	119	33	188	142	142	41	213	164	164	50	241	182	182	59	272	196	196	68	303	210	210	17	144	95	25	168	117	117	34	192	140	140	42	217	162	162	51	248	179	179	60	279	192	192	69	310	204	204	18	151	93	26	174	115	115	35	197	138	138	43	221	160	160	52	255	176	176	61	286	187	187	70	317	198	198	19	158	91	27	180	113	113	36	202	136	136	44	224	158	158	53	262	174	174	62	293	183	183	71	324	192	192

- Shaded Boxes indicate flooded conditions
 - Bold Outlined Boxes indicate Rated Design Values.
 Suction Pressure will be lower than design value if indoor air flow, entering dry bulb, or entering wet bulb temperatures are lower than design.
 - Discharge temperatures greater than charted values indicate a refrigerant undercharge.

*Note: All pressures are listed in psig, and all temperatures in degrees F.

**INSTALLER: PLEASE LEAVE
THESE INSTALLATION
INSTRUCTIONS WITH THE
HOMEOWNER.**

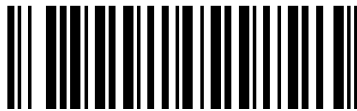

7083080



7083080 (Replaces 7081590)

Specifications and illustrations subject to change
without notice and without incurring obligations.

Printed in U.S.A. (11/03)