

## Residential Gas Furnaces

# Installation Instructions

\*RC 92+ Compact Upflow/Horizontal Condensing Furnace

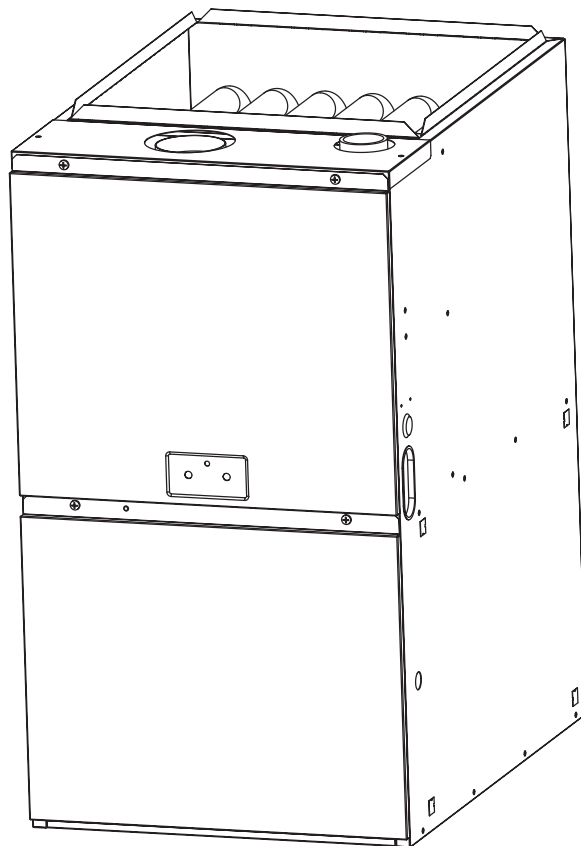

\*RC 92+ Upflow

---

### **WARNING:**

---

Improper installation, adjustment, alteration, service, or maintenance can cause injury or property damage. Refer to this manual for assistance. For additional information consult a qualified installer, service agency, or the gas supplier.

---

These instructions are primarily intended to assist qualified individuals experienced in the proper installation of this appliance. Some local codes require licensed installation/service personnel for this type of equipment. Read all instructions carefully before starting the installation.

**DO NOT DESTROY. PLEASE READ CAREFULLY AND KEEP IN A SAFE PLACE FOR FUTURE REFERENCE.**

---

### **FOR YOUR SAFETY:**

---

Do not store or use gasoline or other flammable vapors and liquids in the vicinity of this or any other appliance.

---

---

### **FOR YOUR SAFETY:**

---

#### **WHAT TO DO IF YOU SMELL GAS:**

- Do not try to light any appliance.
  - Do not touch any electrical switch; do not use any phone in your building.
  - Immediately call your gas supplier from a neighbor's phone. Follow the gas supplier's instructions.
  - If you cannot reach your gas supplier, call the fire department.
  - Extinguish any open flame.
-



## Table of Contents

<b>Furnace Specifications</b> .....	<b>4-5</b>
Furnace Airflow Data .....	5
<b>Safety Information</b> .....	<b>6</b>
<b>Installation Requirements</b> .....	<b>6</b>
<b>Return Air</b> .....	<b>8</b>
<b>Venting and Combustion Air Requirements</b> .....	<b>8</b>
Air Requirements for One-Pipe Installation .....	10
Installation in A Confined Space .....	10
Installation in A Unconfined Space .....	10
• Air From Inside .....	11
• Air Directly Through An Exterior Wall .....	11
• Outdoor Air Through Vertical Openings or Ducts .....	11
• Outdoor Air Through Horizontal Openings or Ducts .....	11
<b>Venting Requirements</b> .....	<b>11</b>
Vent Pipe Material .....	12
Vent Pipe Length and Diameter .....	12
Vent Pipe Installation .....	13
• Pipe Routing & Support .....	13
Location of Outdoor Terminations .....	14
• Horizontal Venting .....	14
• Vertical Venting .....	18
• Vent Freezing Protection .....	19
• Concentric Vent Termination .....	19
<b>Drainage of Condensate From Furnace</b> .....	<b>19</b>
Gas Supply and Piping .....	20
Leak Check .....	20
Conversion .....	21
High Altitude Application .....	21
Natural Gas High Altitude Conversion .....	21
LP/Propane Gas Sea Level and High Altitude Conversion .....	21
<b>Electrical Wiring</b> .....	<b>21</b>
Line Voltage Wiring .....	22
Low Voltage Wiring .....	23
<b>Start-up and Adjustments</b> .....	<b>23</b>
Start-Up Procedure .....	24
Verifying and Adjusting Firing Rate .....	24
Verifying and Adjusting Temperature Rise .....	25
Verifying Burner Operation .....	25
Verifying Operation of the Supply Air Limit Switch .....	25
<b>Description of Components</b> .....	<b>26</b>
<b>Maintenance</b> .....	<b>26</b>
Combustion Air and Vent System .....	27
Air Filter(s) .....	27
Lubrication .....	27
Condensate Drain Assembly .....	27
Blower Compartment .....	27
Heat Exchanger and Burner Maintenance .....	28
<b>System Operation Information</b> .....	<b>28</b>
Sequence of Operation .....	28
<b>Upflow Wiring Diagram</b> .....	<b>29</b>
Furnace Fails to Operate .....	31
Twinning of Two Furnaces .....	31
<b>Installation/Performance Checklist</b> .....	<b>Back Page</b>

# FURNACE SPECIFICATIONS

## Upflow \*RC Furnaces

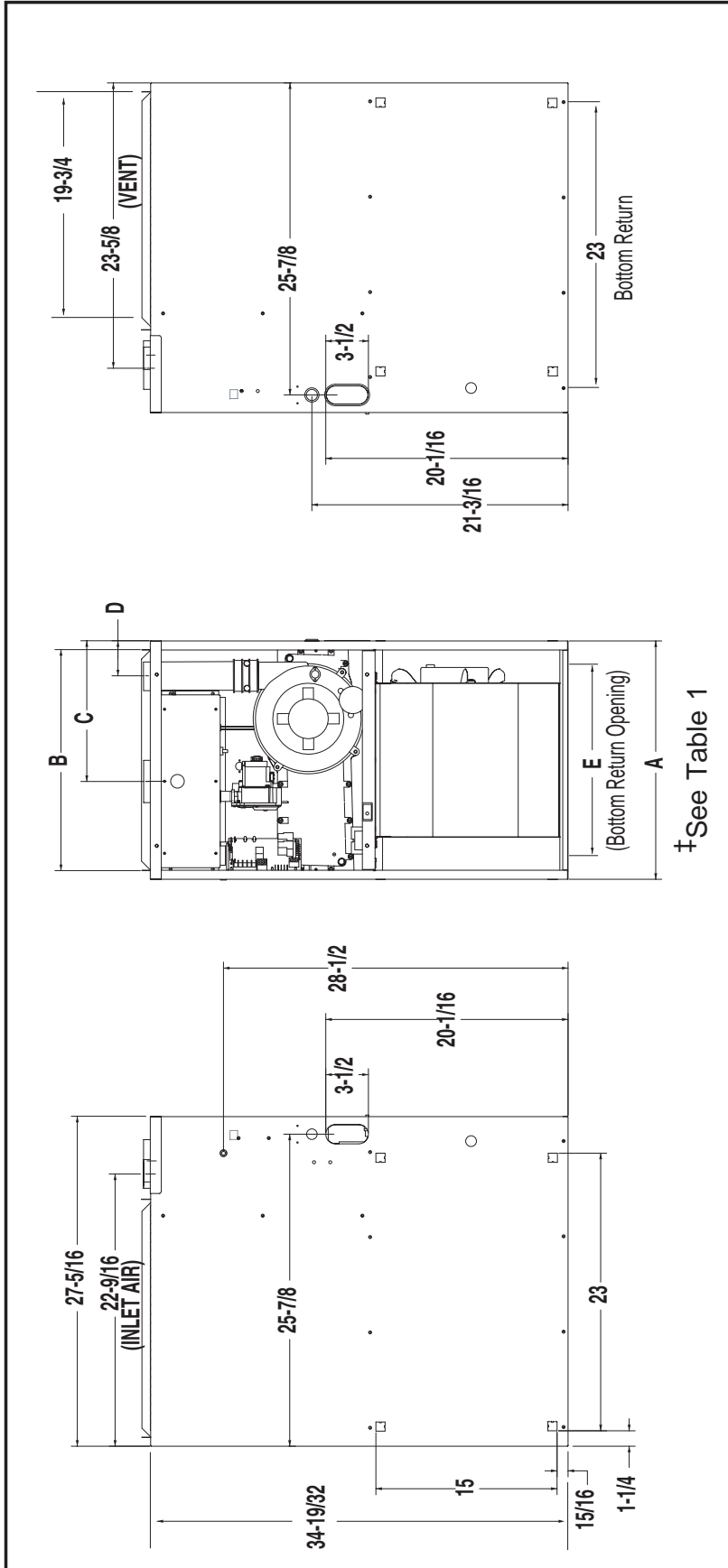

Figure 1. Upflow Unit Dimensions

Model Number	Furnace Input	Dimensions (inches)					Shipping Weight (lbs)
		A	B	C	D	E	
*RC040	38,000	14 1/4	12 13/16	8 5/8	2 11/16	11 3/4	88
*RC060	60,000	14 1/4	12 13/16	8 5/8	2 11/16	11 3/4	92
*RC080	80,000	19 3/4	18 5/16	9 11/16	2 15/16	17 1/4	98
*RC100	100,000	19 3/4	18 5/16	9 11/16	2 15/16	17 1/4	130
*RC120	120,000	22 1/2	21 1/16	13 1/8	2 13/16	20	140

Table 1. Furnace Dimensions and Shipping Weights

# CAPACITIES —Furnace Airflow Data

MODEL NUMBER *RC	HEATING INPUT	MOTOR SPEED	MOTOR HP	EXTERNAL STATIC PRESSURE (INCHES OF WATER COLUMN)																							
				0.1		0.2		0.3		0.4		0.5		0.6		0.7		0.8									
				CFM	Rise	CFM	Rise	CFM	Rise	CFM	Rise	CFM	Rise	CFM	Rise	CFM	Rise	CFM	Rise	CFM	Rise						
040-08A	36,000	HIGH** LOW*	1/5	945	36	920	37	885	39	850	40	815	42	785	43	730	47	675	50								
				720	47	700	49	665	51	630	54	600	57	560	60	510	60	460	60								
060-12A	60,000	HIGH* MEDIUM** LOW	1/3	1300	40	1260	41	1210	42	1170	44	1115	45	1060	48	1000	51	930	55								
				1110	46	1075	47	1050	49	1020	50	985	52	940	54	885	58	820	62	520	-						
080-12B	80,000	HIGH* MEDIUM** LOW	1/3	1495	45	1450	47	1390	49	1310	52	1245	55	1160	58	1030	66	930	71								
				1225	55	1200	57	1155	59	1100	62	1050	65	965	71	885	-	805	64	450	-						
080-16B	80,000	HIGH* MED-HIGH MED-LOW** LOW	1/2	1955	35	1890	36	1825	37	1755	39	1680	41	1605	42	1510	45	1400	49								
				1665	41	1630	42	1580	43	1535	44	1480	46	1420	48	1345	51	1250	55	1085	63						
100-16B	100,000	HIGH* MED-HIGH** MED-LOW LOW	1/2	1415	48	1385	50	1360	50	1325	51	1285	53	1235	55	1170	58	1085	63								
				1200	57	1185	58	1165	59	1140	60	1095	62	1045	65	995	-	930	-								
120-16C	120,000	HIGH* MED-HIGH** MED-LOW LOW	1/2	1955	52	1900	53	1840	55	1770	57	1695	60	1620	63	1520	67	1420	71								
				1670	61	1635	62	1580	64	1545	66	1490	68	1425	70	1360	-	1265	-								
120-20C	120,000	HIGH* MED-HIGH MED-LOW** LOW	3/4	2230	45	2175	47	2120	48	2070	49	2010	51	1935	53	1865	55	1790	57								
				1840	55	1830	55	1810	56	1780	57	1755	58	1710	59	1665	61	1610	65								
				1595	64	1570	65	1550	66	1540	66	1505	68	1455	70	1410	-	1370	-								
				1365	-	1345	-	1335	-	1315	-	1300	-	1275	-	1210	-	1160	-								

\* Factory Set Cooling Speed  
 \*\* Factory Set Heating Speed  
 - Not Recommended

NOTES: 1. Airflow rates of 1800 CFM or more require two return air connections. Data is for operation with filter(s).  
 2. Temperature rises in the table are approximate. Actual temperature rises may vary.  
 3. Temperature rises and airflows for external static pressures greater than 0.5 are for reference only.  
 These conditions are not recommended.

Table 2. Furnace Airflow Data

## SAFETY INFORMATION

1. Use only with type of gas approved for this furnace. Refer to the furnace rating plate.
2. Install this furnace only in a location and position as specified on Table 3 of these instructions.
3. Provide adequate combustion and ventilation air to the furnace space as specified on Pages 12 through 19.
4. Provide adequate clearances around the vent air intake terminal(s) as specified on Figures 17 through 18 of these instructions.
5. Combustion products must be discharged outdoors. Connect this furnace to an approved vent system only, as specified on Pages 12 through 18.
6. Never test for gas leaks with an open flame. Use a commercially available soap solution made specifically for the detection of leaks to check all connections, as specified on Page 20 of these instructions.
7. Always install furnace to operate within the furnace's intended temperature-rise range with a duct system which has an external static pressure within the allowable range, as specified on Table 2 of these instructions. See furnace rating plate.
8. When a furnace is installed so that supply ducts carry air circulated by the furnace to areas outside the space containing the furnace, the return air shall also be handled by duct(s) sealed to the furnace casing and terminating outside the space containing the furnace.
9. A gas-fired furnace for installation in a residential garage must be installed as specified on Page 6 of these instructions.
10. The furnace is not to be used for temporary heating of buildings or structures under construction.

## INSTALLATION REQUIREMENTS

### Requirements and Codes

This furnace must be installed in accordance with these instructions, all applicable local building codes, and the current revision of the National Fuel Gas Code (ANSI-Z223.1, NFPA-54). The current revision of the National Fuel Gas Code is available from:

American National Standards Institute, Inc.  
1430 Broadway  
New York, New York 10018

Canada installations shall comply with CAN/CGA-B149 installation codes, local plumbing or waste water codes and other applicable codes. Additional helpful publications are:

- NFPA-90A - Installation of Air Conditioning and Ventilating Systems.
- NFPA-90B - Warm Air Heating and Air Conditioning Systems.

These publications are available from:  
National Fire Protection Association, Inc.  
Batterymarch Park  
Quincy, Massachusetts 02269



## WARNING:

---

**This furnace is not approved for installation in mobile homes. Installation in a mobile home could cause fire, property damage, and/or personal injury.**

---

### Location

The furnace must be installed on a level surface, and as close to the center of the air distribution system as possible. See Table 1 for overall dimensions to determine the required clearances in hallways, doorways, stairs, etc. to allow the furnace to be moved to the installation point. The furnace must be installed so that all electrical components are protected from water. Minimum clearances to combustible materials are listed in Table 3. Access for positioning and servicing must be considered when locating the unit. 24 inches is the minimum required clearance for servicing the unit. 30 inches is the minimum required clearance for positioning the unit. 36 inches is the recommended clearance from the front of the unit. Please note that a panel or door can be located such that the minimum clearance on the rating plate is satisfied, but that panel or door must be removable and allow the appropriate clearance for your installation.

This furnace is certified for use on wood flooring. The furnace must be installed on a solid surface and must be level front to back and side to side. This furnace must not be installed directly on carpeting, tile, or any combustible material other than wood flooring.

A gas-fired furnace installed in a residential garage must be installed so that the bottom of the furnace is located a minimum of 18" from the floor. The furnace must be located or protected to avoid physical damage by vehicles.

## CLEARANCES TO COMBUSTIBLE MATERIALS

This furnace is Designed Certified by CSA International for the minimum clearances to combustible material listed in Table 3. See the furnace name plate, located inside the furnace cabinet, for specific model number and clearance information.

MINIMUM CLEARANCES TO COMBUSTIBLE MATERIAL						
Furnace Input (Btuh)	Cabinet Width (Inches)	Minimum Clearances (Inches)				
		Side	Vent	Back	Top	Front
38,000	14 1/4	0	0	0	1	1*
60,000	14 1/4	0	0	0	1	1*
80,000	19 3/4	0	0	0	1	1*
100,000	19 3/4	0	0	0	1	1*
120,000	22 1/2	0	0	0	1	1*

\* Allow 36" minimum clearance for service.

**Table 3. Minimum Clearances to Combustible Materials**

## HORIZONTAL INSTALLATIONS

The upflow furnaces are approved for horizontal installation. Installation Kit #904079 is required for all furnaces except for the \*RC120 input. The \*RC120 furnace can only use 3 inch venting, and requires kit # 904080, see Table 4. **An additional pressure switch is required for horizontal installation, and is included in the kits.** Follow the installation instructions in the kit for proper conversion.

	HORIZONTAL KIT PART NO.	
	904079 (2 INCH)	904080 (3 INCH)
L1CR040	✓	✓
L1RC060	✓	✓
L1CR080	✓	✓
L1RC100	✓	✓
L1RC120		✓

**Table 4. Horizontal Kit Usage by Model**

## CIRCULATING AIR SUPPLY

Plenums and air ducts must be installed in accordance with the Standard for the Installation of Air Conditioning and Ventilating Systems (NFPA No. 90A) or the Standard for the Installation of Warm Air Heating and Air Conditioning Systems (NFPA No. 90B).

If outside air is utilized as return air to the furnace for ventilation or to improve indoor air quality, the system must be designed so that the return air to the furnace is not less than 50°F (10°C) during heating operation. If a combination of indoor and outdoor air is used, the ducts and damper system must be designed so that the return air supply to

the furnace is equal to the return air supply under normal, indoor return air applications.

When a cooling system is installed which uses the furnace blower to provide airflow over the indoor coil, the coil must be installed downstream (on the outlet side) or in parallel with the furnace.

If a cooling system is installed in parallel with the furnace, a damper must be installed to prevent chilled air from entering the furnace and condensing on the heat exchanger. If a manually operated damper is installed, it must be designed so that operation of the furnace is prevented when the damper is in the cooling position and operation of the cooling system is prevented when the damper is in the heating position.

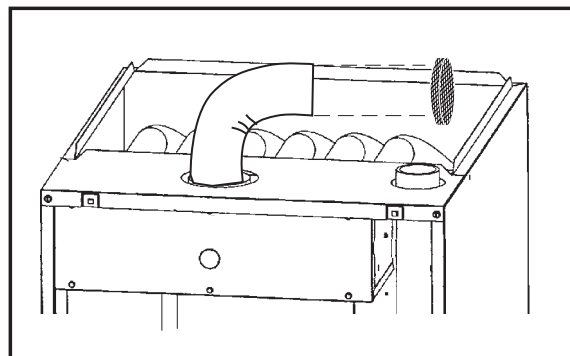

**Figure 2. Protective Screen for One Pipe Installations**

## Return Air

The return air ductwork may be connected to any or all of the following: left side return, right side return, or bottom return. Table 2 shows the airflow data for each furnace model. **Where maximum airflow is 1800 CFM or more two openings must be used.**

## VENTING AND COMBUSTION AIR REQUIREMENTS

NORDYNE condensing furnaces may be installed with outdoor combustion air piped directly to the furnace, or without such special piping. Codes refer to the former as “direct vent” or “two pipe” installation. Installation with air

### **WARNING:**

**Products of combustion must not be allowed to enter the return air ductwork or the circulating air supply. Failure to prevent products of combustion from being circulated into the living space can create potentially hazardous conditions including carbon monoxide poisoning that could result in personal injury or death.**

All return ductwork must be adequately sealed, all joints must be taped, and the ductwork must be secured to the furnace with sheet metal screws. When return air is provided through the bottom of the furnace, the joint between the furnace and the return air plenum must be sealed.

The floor or platform on which the furnace is mounted must provide sound physical support of the furnace with no gaps, cracks, or sagging between the furnace and the floor or platform.

Return air and circulating air ductwork must not be connected to any other heat producing device such as a fireplace insert, stove, etc.

taken from around the furnace is sometimes referred to as “one pipe” installation - i.e. only the vent (exhaust) pipe is provided.

Provisions must be made for adequate supply of air for combustion and ventilation. For United States installations, the adequacy of air provisions can be determined by consulting the current version of the National Fuel Gas Code (ANSI Z223.1/NPFA-54). For Canadian installations, requirements are specified in the National Standard of Canada (CAN/CGA B149.1 & .2). Consult local codes for special requirements.

An important consideration in selecting one or two pipe installation is the quality of the combustion air. Indoor air is sometimes contaminated with various household chemicals which can cause severe corrosion in the furnace combustion system.

NOTE: If the furnace is operated without adequate air for combustion and ventilation, it may not perform properly. Furnace components may be strained by high temperature and could fail.

### **WARNING:**

**Furnace installation using methods other than those described in the following sections must comply with the National Fuel Gas Code and all applicable local codes to provide sufficient combustion air for the furnace.**

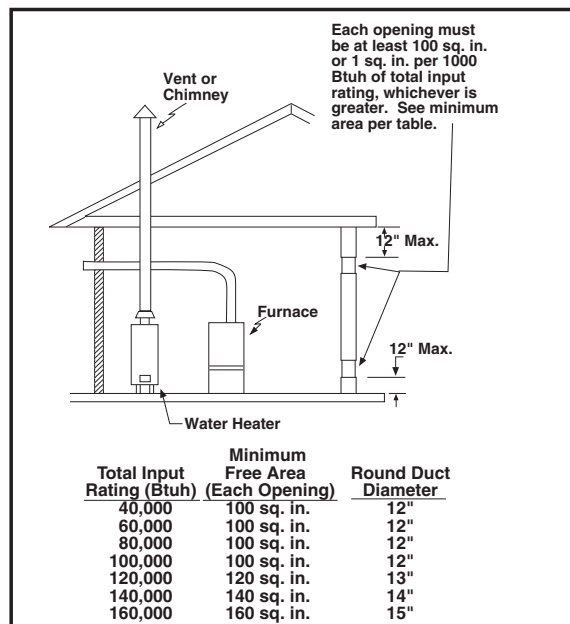

**Figure 3. Equipment in a Confined Space with all Combustion Air drawn from Inside**

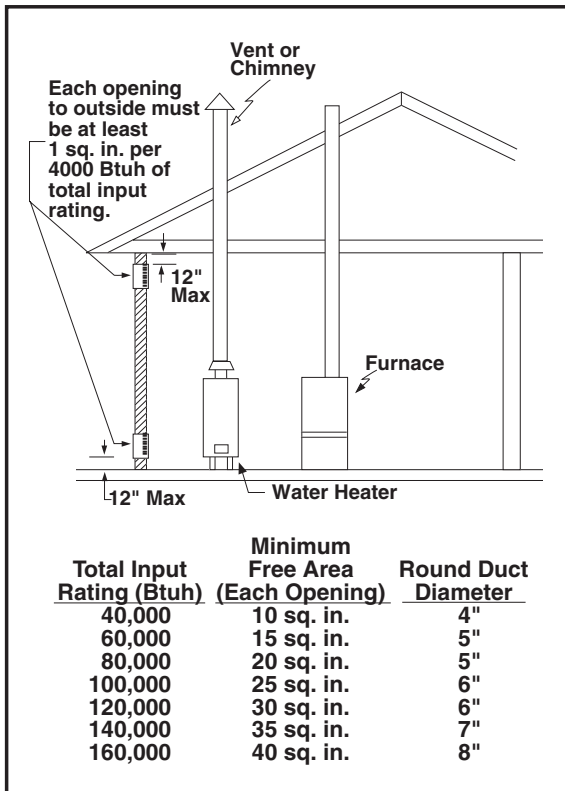

Figure 4. Equipment in a Confined Space with all Combustion Air drawn from Outdoors through Exterior Wall

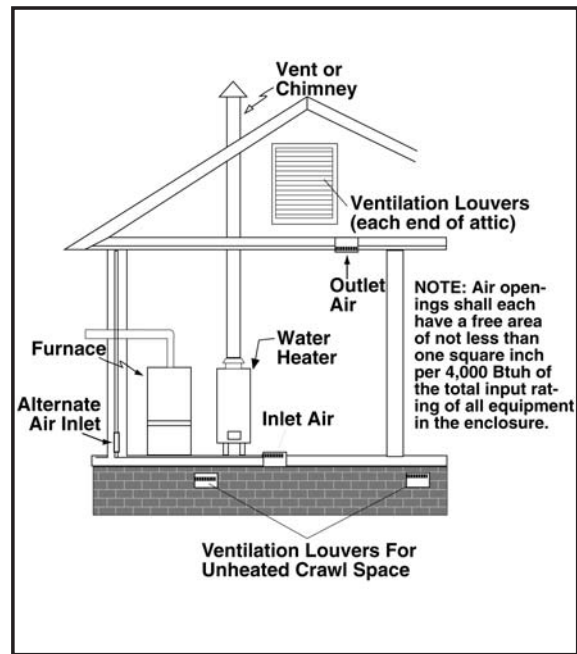

Figure 6. Equipment in a Confined Space with all Combustion Air drawn from Outdoors through Ventilated Crawl Space and Ventilated Attic

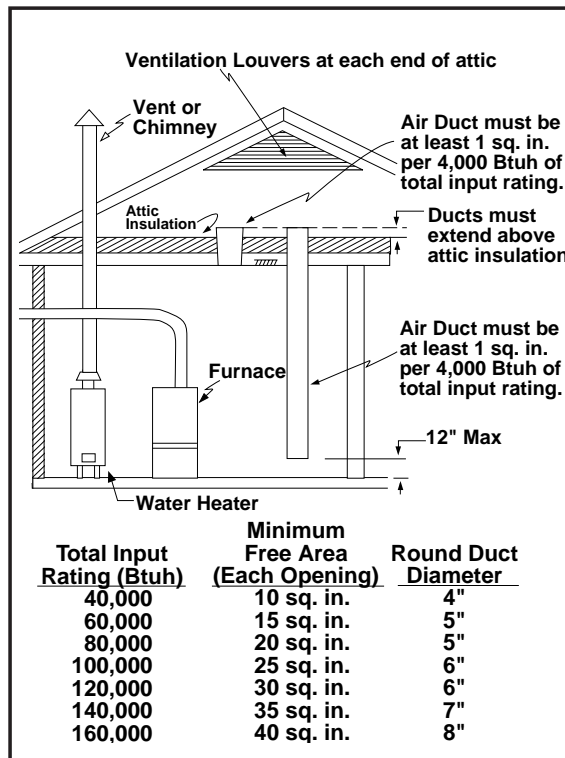

Figure 5. Equipment in a Confined Space with all Combustion Air drawn from Outdoors through Vertical Ducts – from Ventilated Attic

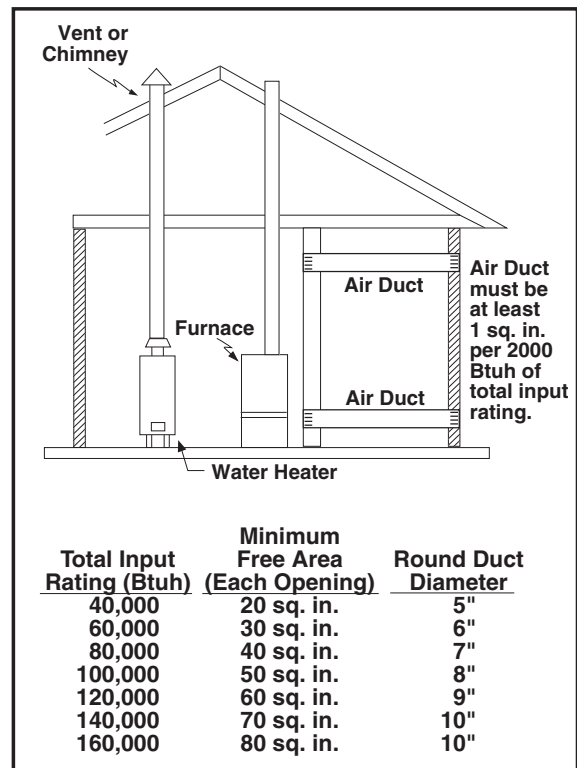

Figure 7. Equipment in a Confined Space with all Combustion Air Drawn from the Outside through Horizontal Ducts

## Combustion Air Quality

The recommended source of combustion air is to use the outdoor air supply. However, the use of indoor air in most applications is acceptable except as follows:

1. If the furnace is installed in a confined space it is recommended that the necessary combustion air come from the outdoors by way of attic, crawl space, air duct, or direct opening.
2. If outdoor combustion air is used, there must be no exposure to the installations or substances listed in Item 3 below.
3. The following types of installation may require **Outdoor Air** for combustion, due to chemical exposures:
  - Commercial buildings
  - Buildings with indoor pools
  - Furnaces installed in laundry rooms
  - Furnaces installed in hobby or craft rooms
  - Furnaces installed near chemical storage areas

Exposure to the following substances in the combustion air supply may also require **Outdoor Air** for combustion:

- Permanent wave solutions
- Chlorinated waxes and cleaners
- Chlorine based swimming pool chemicals
- Water softening chemicals
- De-icing salts or chemicals
- Carbon tetrachloride
- Halogen type refrigerants
- Cleaning solvents (such as perchloroethylene)
- Printing inks, paint removers, varnishes, etc.
- Hydrochloric acid
- Cements and glues
- Antistatic fabric softeners for clothes dryers
- Masonry acid washing materials

## Combustion Air Requirements For One-Pipe Installation

When air for combustion is to be taken from around the furnace, a protective screen must be installed over the combustion air intake opening. This screen is provided with the furnace installation instructions and functions to prevent

debris from entering the combustion system. It should be installed on the combustion air intake collar or inlet PVC. If furnace location is such that this opening might be unintentionally obstructed, a 3" PVC elbow should be installed on the collar, and the screen placed inside the inlet of the elbow. See Figure 2.

## Installation In An Unconfined Space

### **CAUTION:**

**“Tight” buildings (with weather stripping and caulk to reduce infiltration), may require special provisions for introduction of outside air to ensure satisfactory combustion and venting, even though the furnace is located in an unconfined space.**

An unconfined space is an area including all rooms not separated by doors with a volume greater than 50 cubic feet per 1,000 Btuh of the combined input rates of all appliances which draw combustion air from that space. For example, a space including a water heater rated at 45,000 Btuh and a furnace rated at 75,000 Btuh requires a volume of 6,000 cubic feet [ $50 \times (45 + 75) = 6,000$ ] to be considered unconfined. If the space has an 8 foot ceiling, the floor area of the space must be 750 square feet ( $6,000 / 8 = 750$ ). In general, a furnace installed in an unconfined space will not require outside air for combustion.

### **WARNING:**

**Furnaces installed with combustion air drawn from a heated space which includes exhaust fans, fireplaces, or other devices that may produce a negative pressure should be considered confined space installations.**

## Installation In A Confined Space

A confined space is one which does not meet the unconfined space volume requirements, and typically involves installation in a small room. All such installations must have specific provisions for introduction of combustion and ventilation air. *Codes require that two openings be provided for this - one with bottom edge within 12"*

of the floor and one with top edge within 12" of the ceiling. The size and other criteria for these openings must be per the following sections.

Combustion air openings must not be restricted in any manner.

For furnaces installed in a confined space, all joints must be taped, and the ductwork must be secured to the furnace with sheet metal screws.

#### *Air From Inside*

Air for combustion and ventilation may be taken from inside the building through an interior wall if the building is not "tight" and if the total volume of the furnace space and the space from which air is drawn meets the volume requirements for an unconfined space. In such cases, the two openings in the wall must each have free area of at least one square inch per 1000 Btuh of total appliance input, but not less than 100 square inches of free area. See Figure 4. For example, if the combined input rate of all appliances is less than or equal to 100,000 Btuh, each opening must have a free area of at least 100 square inches. If the combined input rate of all appliances is 120,000 Btuh, each opening must have a free area of at least 120 square inches.

#### *Air Directly Through An Exterior Wall*

If combustion air is provided directly through an exterior wall, the two openings must each have free area of at least one square inch per 4000 Btuh of total appliance input. (See Figures 3 and 4.)

#### *Outdoor Air Through Vertical Openings or Ducts*

If combustion air is provided through vertical ducts or openings to attics or crawl spaces, the two openings must each have free area of at least one square inch per 4000 Btuh of total appliance input. Ducts must have cross-sectional areas at least as large as the free area of their respective openings to the furnace space. Attics or crawl spaces must communicate freely with the outdoors if they are the source of air for combustion and ventilation. (See Figures 5 and 6.)

#### *Outdoor Air Through Horizontal Openings or Ducts*

If combustion air is taken from outdoors through horizontal ducts, the openings must each have free area of at least one square inch per 2000

Btuh of total appliance input. Ducts must have cross-sectional area at least as large as the free area of their respective openings to the furnace space. (See Figure 7.)



## **CAUTION:**

---

**Do not supply combustion air from an attic space that is equipped with power ventilation or any other device that may produce a negative pressure.**

---

## **VENTING REQUIREMENTS**

This section specifies installation requirements for vent and "2-pipe" combustion air piping. For "one pipe" installations, install vent piping per this section and provide air for combustion and ventilation per the previous section. The capacity table provided in this section applies to the total of vent and combustion air piping for either type of installation.

NORDYNE condensing furnaces are classified as "Category IV" appliances, which require special venting materials and installation procedures. Category IV appliances operate with positive vent pressure and therefore require vent systems which are thoroughly sealed. They also produce combustion condensate, which is slightly acidic and can cause severe corrosion of ordinary venting materials. Furnace operation can be adversely affected by restrictive vent and combustion air piping. Therefore, vent and combustion air piping lengths must conform completely to the requirements of Table 4.

The furnace must be vented to the outdoors. It must not be vented in common with any other appliance, even if that appliance is of the condensing type. Common venting can result in severe corrosion of other appliances or their venting and can allow combustion gases to escape through such appliances or vents. Do not vent the furnace to a fireplace chimney or building chase.



## **WARNING:**

---

**FURNACE MUST NOT BE COMMON VENTED WITH OTHER APPLIANCES.**

---

## Vent Pipe Material

Vent and combustion air pipe and fittings must be one of the following materials and must conform to the indicated ANSI/ASTM standards:

<u>Material</u>	<u>Standard</u>
Schedule 40 PVC	D1785
PVC-DWV	D2665
SDR-21*	D2241
& SDR-26*	
ABS-DWV	D2661
Schedule 40 ABS	F628
Foam/Cellular Core PVC	F891

\*In Canada, check the local codes to ensure that SDR is approved for use. SDR is not approved for all Canadian installations.

Cement and primer must conform to ATSM Standard D2564 for PVC and Standard D2235 for ABS. When joining PVC piping to ABS, use PVC solvent cement. (See procedure specified in ASTM Standard D3138.)

## Vent Pipe Length and Diameter

In order for the furnace to operate properly, the combustion air and vent piping must not be excessively restrictive. To ensure this use Table 5, which indicates the maximum allowable piping length for a furnace of specified input rate, when installed with piping of selected diameter and number of elbows. This table applies to the length and number of elbows for each pipe. To

use the table, the furnace input rate, the centerline length and the number of elbows on each pipe must be known. Choose the diameter for which the tabulated length is equal to or greater than required.

Proper use of the table is illustrated by the following example:

### Example:

An 80,000 Btu/h furnace is to be installed in a "one-pipe" system with 20 feet of vent piping. There are a total of four long radius 90-degree elbows used in the vent, including the one exterior to the building.

### Solution:

For this particular installation, the equivalent vent length must be calculated. This equivalent vent length will then be compared to the maximum allowable vent length given in Table 5. Then, the diameter of the piping can be chosen for which the equivalent vent length is less than the maximum allowable vent length. Returning to our example, we consult Table 5 and determine that for an 80,000 Btu/h furnace the maximum vent length for 2" diameter piping is 30 feet or for 3" diameter piping is 90 feet. Note that the maximum vent length given in Table 5 includes one long radius elbow. Therefore, for our example, we have three additional long radius elbows for which we must add to our piping. Each long radius elbow is equivalent to 2.5 feet, so we must add 7.5 feet to our vent length.

MODELS	SINGLE PIPE LENGTH (FT.) with 1 long radius elbow**		DIRECT VENT, DUAL PIPE LENGTH (ft.) with 1 long radius elbow on each pipe**	
	OUTLET	OUTLET	INLET/OUTLET	INLET/OUTLET
	2"	3"	2"	3"
*RC040	60	90	30	90
*RC060	50	70	30	50
*RC080	30	90	15	90
*RC100	50	70	20	60
*RC120	N/A	40	N/A	40

### \*\*NOTES

1. Subtract 2.5 ft. for each additional 2" **long** radius elbow, 5 ft. for each additional 2" **short** radius elbow, 3.5 feet for each additional 3" **long** radius elbow, and 7 feet for each additional 3" **short** radius elbow.
2. Two 45 degree elbows are equivalent to one 90 degree elbow.
3. Do not include termination elbows in calculation of vent length
4. This table is applicable for elevations from sea level to 2000 ft. For higher elevations decrease vent pipe lengths by 8% per 1000 ft. of altitude.
5. Only the above pipe materials are approved for use with these condensing furnaces.

**Table 5. Vent Table**

Therefore, the equivalent vent length for our installation is 27.5 feet. We compare this with the maximum vent length for 2" and 3" diameter piping. For both cases, our equivalent vent length is less than the maximum allowable vent length, so for our "one-pipe" installation we can use either 2" or 3" diameter piping.

Condensing furnace combustion products have very little buoyancy, so Table 5 is to be used without consideration of any vertical rise in the piping.

**NOTE:** Always use the same or larger size piping for combustion air as is used for the exhaust vent.

## Vent Pipe Installation

### *Pipe Routing and Support*

Route piping as directly as possible between the furnace and the outdoors and remember that routing affects pipe size requirements per the preceding section. If a two pipe system is used, locate the combustion air intake and the vent exhaust in the same atmospheric pressure zone meaning both must exit the building through the same portion of exterior wall or roof (See Figure 19). Vent piping must be sloped

upwards not less than 1/4" per foot in the direction from the furnace to the terminal. This is to ensure that any condensate flows back to the furnace (where it can be disposed of through the condensate disposal system).

The quality of outdoor air must also be considered. Be sure that the combustion air intake is not located near a source of solvent fumes or other chemicals which can cause corrosion of the furnace combustion system.

## **CAUTION:**

**Combustion air must not be drawn from a corrosive atmosphere.**

Piping must be mechanically supported so that its weight does not bear on the furnace. Supports must be at intervals no greater than five feet, and at smaller intervals if necessary to ensure that there are no sagging sections to trap water. (See Figure 8.) It is recommended to install couplings along the vent pipe, on either side of the exterior wall. These couplings may be required by local code.

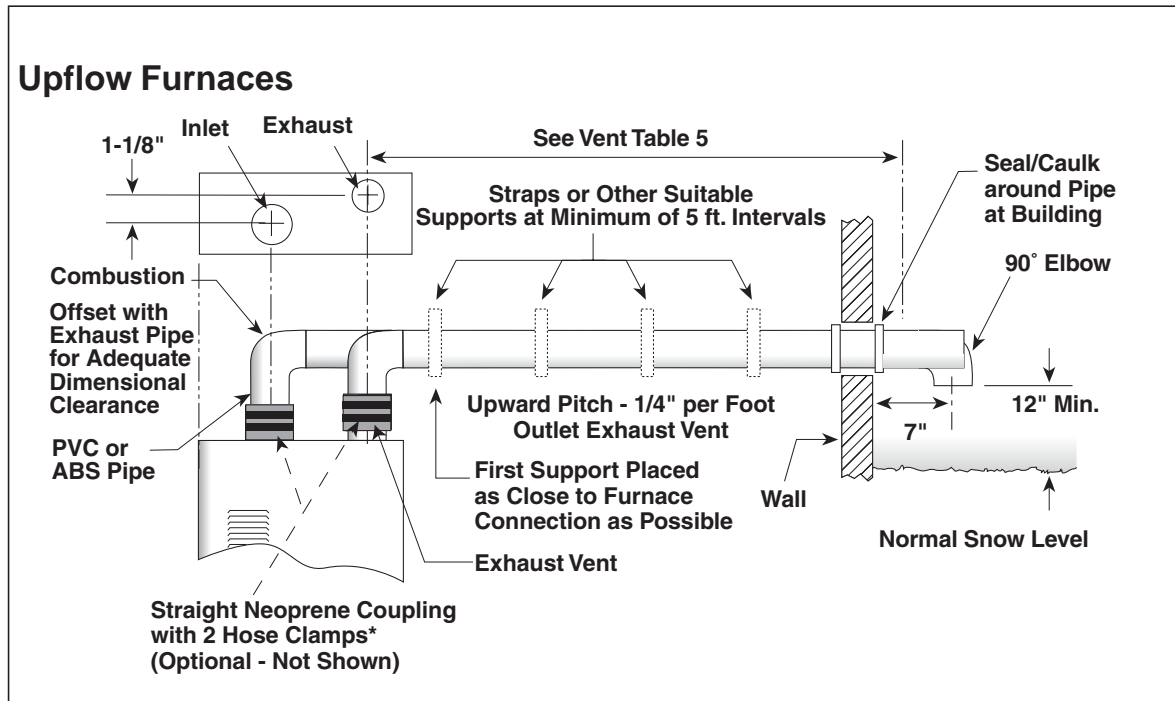

**Figure 8. Horizontal Venting**

\* These neoprene couplings are field-supplied and can be used if the installation requires breakable connections in the piping. Note that a maximum of two couplings per pipe are allowed.

Figure 10 illustrates vent and combustion air pipe sizes exiting the furnace. Transition to the correct pipe size must be done close to the furnace so that the full length of pipe is of proper size.

On an upflow furnace installation, if breakable connections are required in the combustion air inlet (if present) and exhaust vent piping, then straight neoprene couplings for 2" or 3" piping with hose clamps can be used. These couplings can be ordered through your local furnace distributor.

To install a coupling, slide the rubber coupling over the end of the pipe that is attached to the furnace and secure it with one of the hose clamps. Then slide the other end of the rubber coupling onto the other pipe from the vent and secure the coupling with the second hose clamp. Ensure that the connection is tight and leak free.

If desirable, the vent pipe supplied with the furnace can be removed, and approved vent material can be mounted directly into the in-line drain assembly.

NORDYNE condensing furnaces have been certified for installation with zero clearance between vent piping and combustible surfaces. However, it is good practice to allow space for convenience in installation and service.

## Location of Outdoor Terminations

### Horizontal Venting

Vent and combustion air intake terminations must be as shown in Figure 8. Vent termination clearances shall be consistent with the National Fuel Gas Code, ANSI 2223.1/NFPA 54 and/or the CSA B149.1, Natural Gas and Propane Installation Code.

All minimum clearances specified must be maintained to protect building materials from degradation by flue gases.

## **! WARNING:**

**Ensure that the combustion air vent and the exhaust vent are configured as shown in Figure 14. Improper vent termination can cause recirculation of the flue gases. This may result in furnace vibration. In severe cases, the furnace will cycle due to the intermittent contact between the flame and the flame sensor. If you note oscillations occurring, check the vent configuration. Make sure that the exhaust vent does not have a 90 degree termination.**

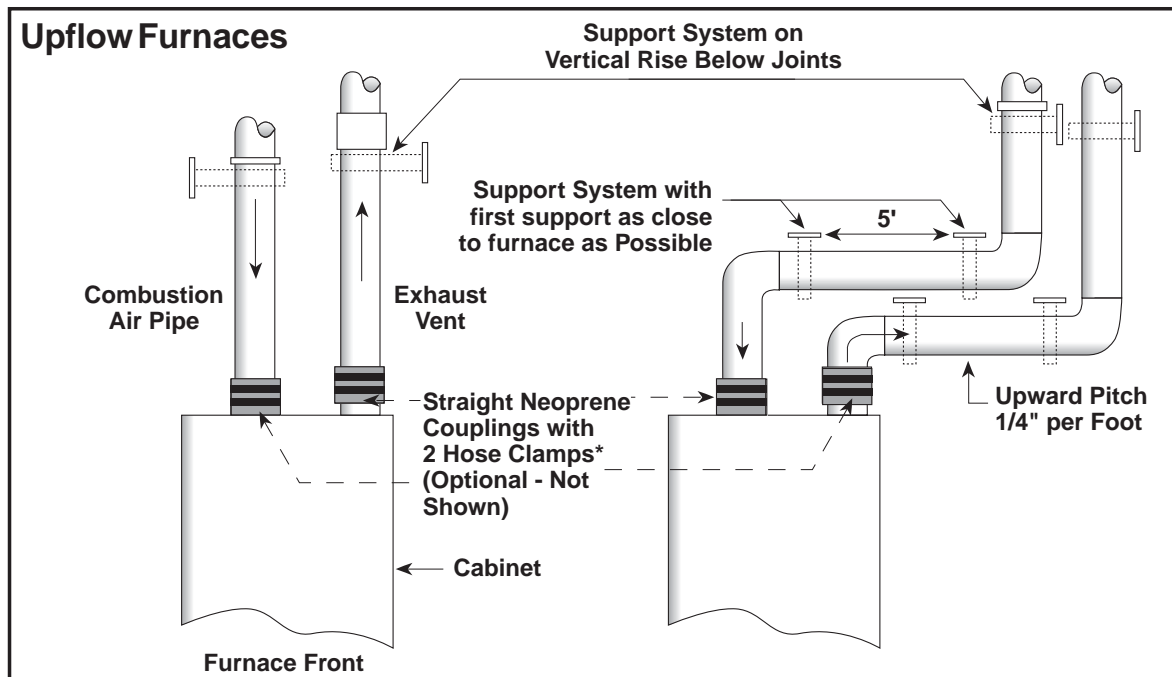

**Figure 9. Vertical Venting**

\* These couplings are field-supplied and can be used if the installation requires breakable connections in the piping. Note that a maximum of two couplings per pipe are allowed.

## Upflow Furnaces

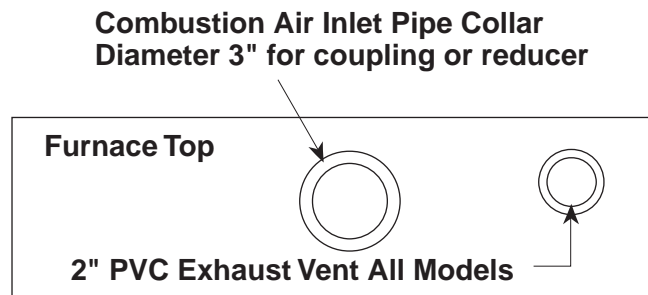

**Figure 10. Furnace Pipe Adaptions**

Vent and combustion air intake terminations must be located to ensure proper furnace operation and to conform to applicable codes. Figure 11 and 12 illustrate necessary distances from the vent termination to windows and building air intakes. **In Canada, the Canadian Fuel Gas Code takes precedence over these instructions. Specifically, all minimum distance requirements with respect to termination of the vent piping outlined in Figures 11 and 12.**

The vent termination shall be located at least 4 ft. horizontally from any electric meter, gas meter, regulator and any relief equipment. These distances apply ONLY to U.S. installations. In Canada, the Canadian Fuel Gas Code takes precedence.

Avoid areas where condensate drainage may cause problems by dropping on planters or patios, etc. Also ensure that exhaust gases will not impinge on windows or building surfaces, which may be compromised or damaged by condensation. Do not install the vent terminal such that exhaust is directed into window wells, stairwells, under decks or into alcoves or similar recessed areas, and do not terminate above any public walkways.

---

### **CAUTION:**

---

**For optimum performance, vent furnace through wall which experiences the least exposure to winter winds.**

---

For horizontal venting, one of the following kits is recommended:

For Canadian installations please refer to the Canadian Installation Code (CAN/CGA-B149.1 or 2) and/or local codes.

The kit consists of two face plates and an insulating gasket to seal the exterior surface. A hole sized closely to the pipe diameter must first be cut through the wall. A short length of pipe is then cut such that it can penetrate the wall and be held in place by closely fitting standard couplings. The face plates are retained on both sides of the wall by the couplings, and the gasket is retained against the wall by the outer face plate. Face plates must be fastened to the wall and the outside one must be flashed as appropriate to prevent entry of water.

When the above kits are not used the following steps are required:

1. Check the hole size cut through the exterior wall. Insure that the hole diameter is less than the diameter of the couplings to be used.
2. Extend the vent pipe through the wall approximately 1" and seal the area between the wall and pipe.
3. If required by local code apply couplings to the vent pipe on the interior and exterior sides of the wall to insure the pipe can not be pushed or pulled through the wall.
4. Insure the combustion air inlet pipe (for a 2 pipe installation) has a 90 degree termination elbow as shown in Figures 14 and 15.

**Note:** A combustion air intake must be terminated with an elbow opening downward. The screen provided with the furnace must be installed in the elbow to prevent entry of debris or creatures.

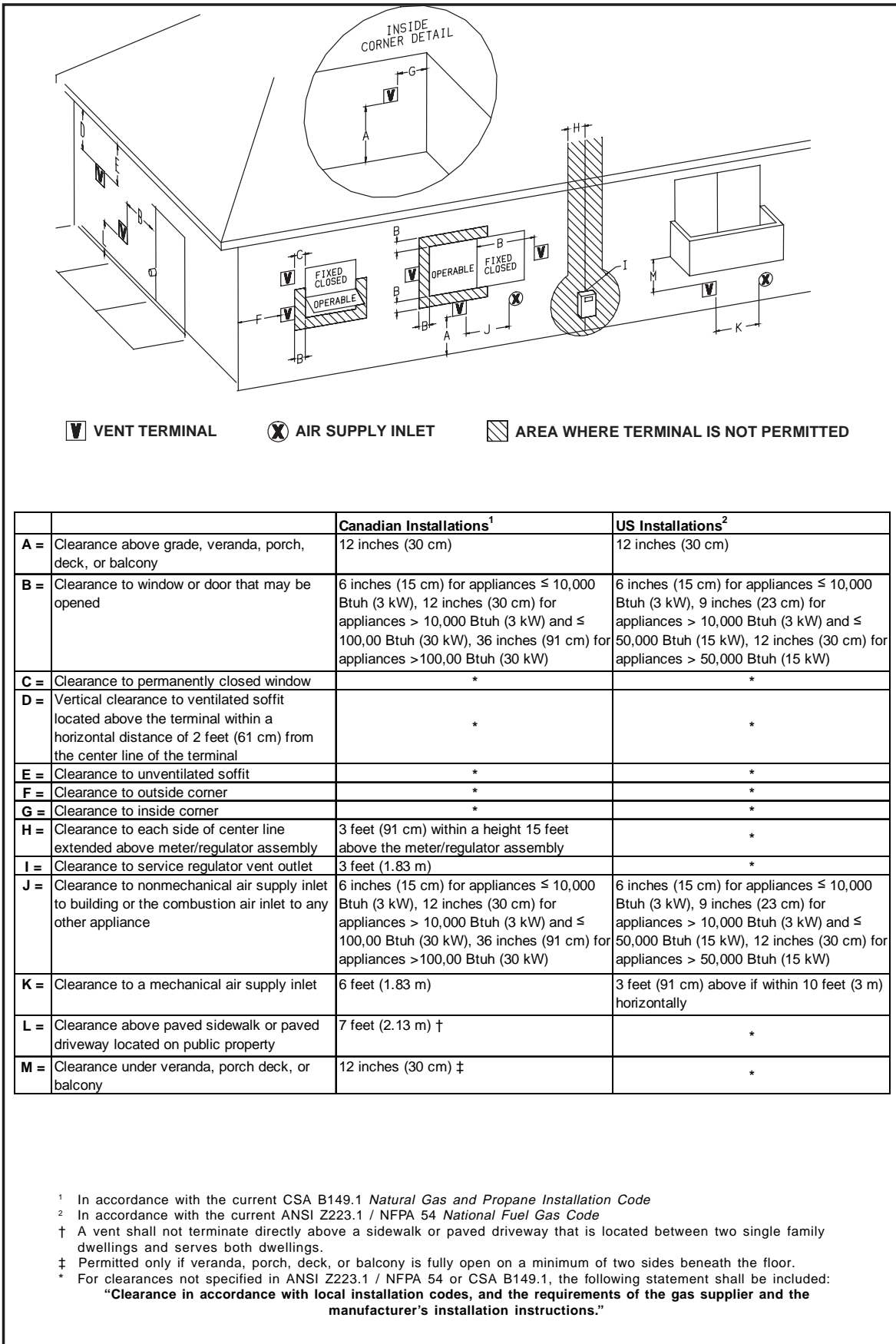

**Figure 11. Vent Termination Clearances for Direct Vent Furnaces**

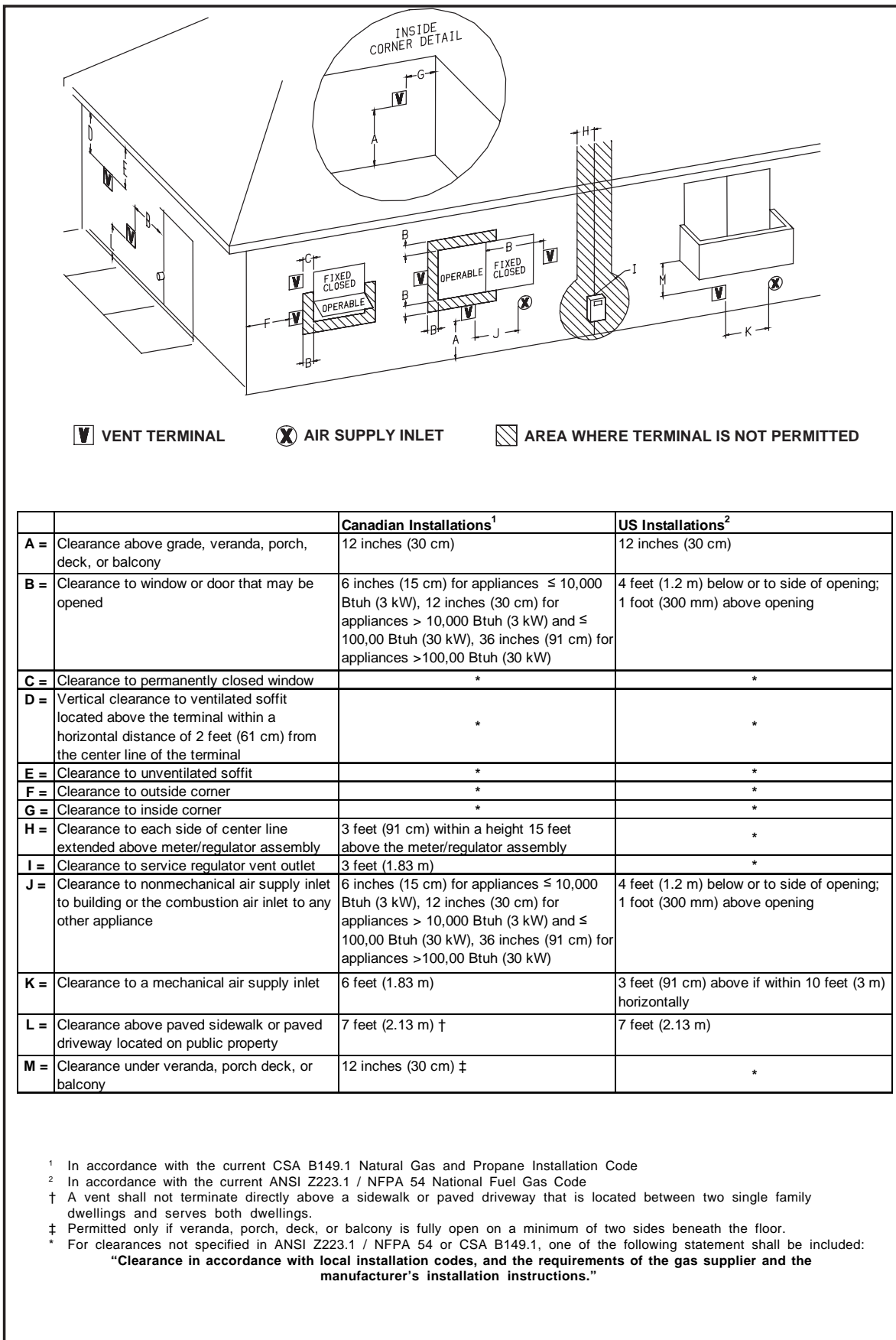

**Figure 12. Vent Termination Clearances for Other Than Direct Vent Furnaces**

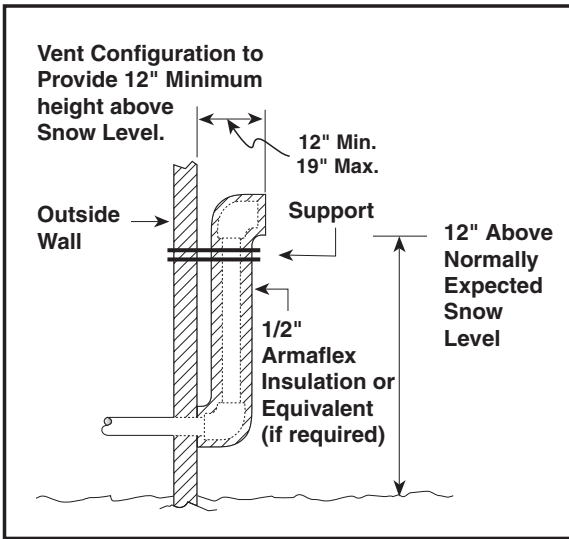

**Figure 13. Alternate Horizontal Vent Installation**

When the vent pipe must exit an exterior wall close to the grade or expected snow level, a riser should be provided as shown in Figure 13. Insulation is required to prevent freezing of this section of pipe.

Table 6 describes the maximum length of flue pipe that can travel through an unconditioned space or an exterior space. The total vent length must not exceed the lengths noted on Table 4.

*Vertical Venting*

Figure 15 shows the proper installation and clearances for vertical vent termination. The roof penetration must be properly flashed and waterproofed with a plumbing roof boot or equivalent flashing. Termination spacing requirements from the roof and from each other must be per Figure 15.

Winter Design Temperature (°F)	Maximum Flue Pipe Length in Unconditioned and Exterior Spaces	
	Without Insulation (feet)	With Insulation (feet) ‡
20	45	70
0	20	70
-20	10	60

‡ = Insulation thickness greater than 3/8 inch, based on an R value of 3.5 (ft\*°F\*hr)/(BTU\*in)

**Table 6 Vent Protection**

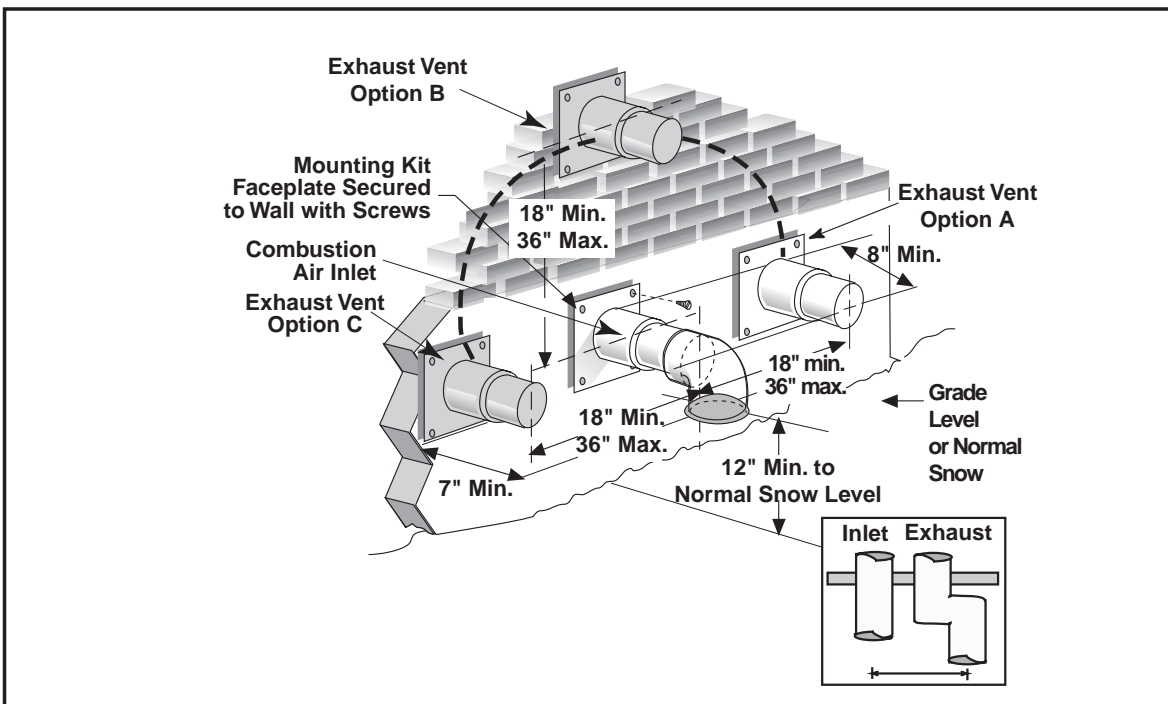

**Figure 14. Exhaust and Combustion Air Pipe Clearances**

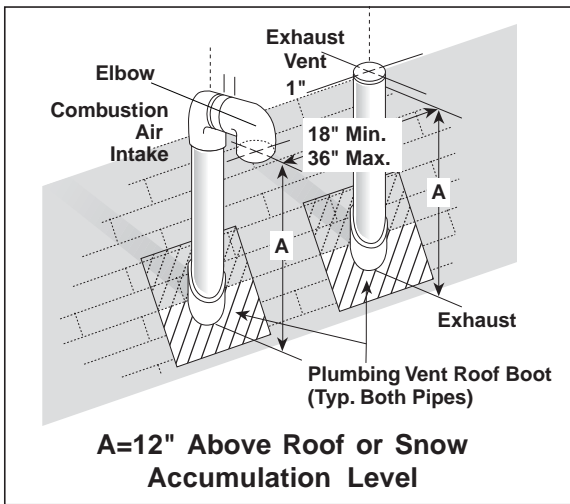

**Figure 15. Vertical Vent Termination**

Vent and combustion air piping may be installed in an existing chimney which is not in use provided that:

- a. Both the exhaust vent and air intake run the length of the chimney.
- b. The top of the chimney is sealed and weatherproofed.
- c. The termination clearances shown in Figure 15 are maintained.
- d. No other gas fired or fuel-burning equipment is vented through the chimney.

#### *Vent Freezing Protection*

When the vent pipe is exposed to temperatures below freezing, i.e., when it passes through unheated spaces, chimneys, etc., the pipe must be insulated with 1/2 inch thick sponge rubber insulation, Armaflex-type insulation or equivalent. Insulating pipe is important to avoid condensate icing.

For extremely cold climates or for conditions of short furnace cycles (i.e. set back thermostat conditions) the last three feet of vent pipe can be reduced one nominal pipe size provided that the total vent length is at least 15 feet in length and the vent is sized in accordance with the venting requirements (Table 5) before this reduction is applied. (Example: 3" to 2-1/2" or 2" to 1-1/2") Smaller vent pipes are less susceptible to freezing, but must not be excessively restrictive.

#### *Concentric Vent Termination*

Concentric vent termination kits are approved for use with these furnaces. The kit part numbers are 904176 (3 inch) and 904177 (2 inch). For proper installation of the concentric vent

termination, follow the installation instructions provided with that kit.

## **DRAINAGE OF CONDENSATE FROM FURNACE**

The condensate drainage system is internal to the furnace. **DO NOT** connect additional traps to the exterior of the furnace. Doing so will have adverse effects on the operation of the furnace. The drain may exit either the right or left side of the furnace cabinet.

The condensate drain can be routed to a flow drain or to a condensate pump. Ensure that the drain maintains a downward slope from the unit to the drain. Refer to Figure 16 for more details.

For a right side drain simply extend the tubing out of the 7/8" hole in the cabinet, see Figure 16. For a left side drain follow the steps below:

1. Loosen the clamp on the soft exit tube (see Figure 16.)
2. Rotate the soft exit tube counter clockwise, 180°.
3. Re-tighten the clamp. **MAKE SURE CLAMP IS TIGHT TO AVOID LEAKAGE OF CONDENSATE.**
4. Route the tubing out of the 7/8" hole located 8 inches up from the bottom furnace.

The condensate should drain from the plastic collector box (location A in Figure 16) as droplets or a small stream. If you notice the furnace has operated for more than 5 minutes without draining or the red status light on the control board is pulsing a 2-blink code follow the steps below.

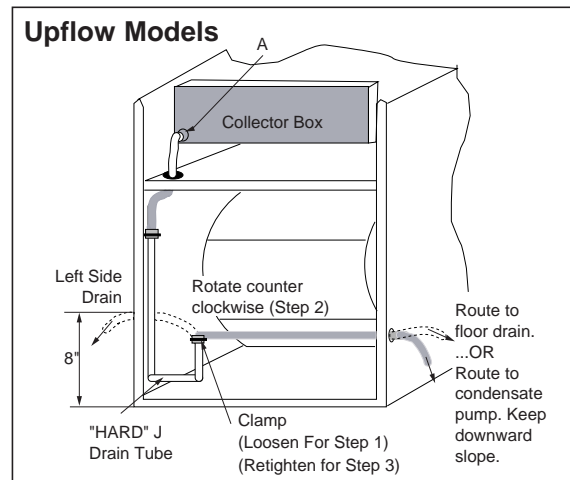

**Figure 16. Furnace with Condensate Drain Trap Assembly**

1. Remove the collector box soft tube at location A in Figure 16 and insure the exit from the collector box is clear of any debris or obstructions.
2. Replace this tube and insure the fit to the header spout is airtight. Air will be drawn into the header if this connection is not tight.
3. Check other tube connections along the drain system. Insure that all are airtight.

NOTE: Industry research studies indicate that when condensate is routed to an active drain, household detergents, etc., buffer its acidity. If the drain is not actively used or if codes require, obtain a neutralizer kit (usually contains limestone). Proper drains and connections to the condensate tubing are required as NORDYNE cannot be held responsible for water leakage which occurs due to loose hose connections or improperly sealed drain line pipes.

## GAS SUPPLY AND PIPING

This furnace is equipped for either left or right side gas entry. Typical gas service hook-ups are shown in Figure 17. When making the gas connection provide clearance between the gas supply line and the entry hole in the furnace casing to avoid unwanted noise and/or damage to the furnace.

All gas piping must be installed in compliance with local codes and utility regulations. Some local regulations require the installation of a manual main shut-off valve and ground joint union external to the furnace. The shut-off valve should be readily accessible for service and/or emergency use. Consult the local utility or gas supplier for additional requirements regarding placement of the manual main gas shut-off. In the absence of local codes the gas line installa-

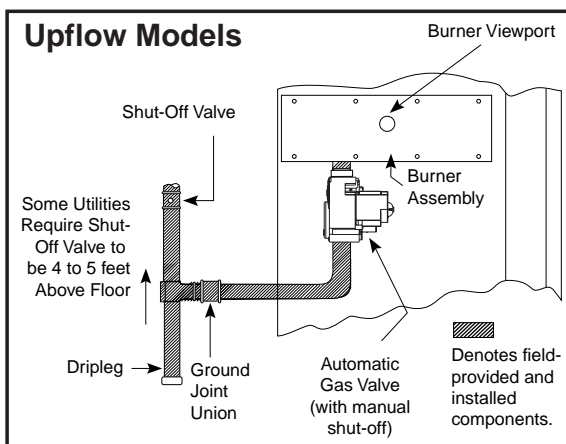

Figure 17. Typical Gas Service Connection

tion must comply with the latest edition of the National Fuel Gas Code (ANSI Z223.1) or (CAN/CGA B149) installation codes.

An 1/8" NPT plugged tap must be installed in the gas line to the unit for use when measuring the gas supply pressure. The plug should be readily accessible for service use. A drip leg should be installed in the vertical pipe run to the unit. Table 7 lists gas flow capacities for standard pipe sizes as a function of length in typical applications based on nominal pressure drop in the line.

NOTE: Gas piping must not be run in or through air ducts, chimneys, gas vents, elevator shafts, etc.

Compounds used on threaded joints of gas piping must be resistant to the actions of liquefied petroleum gases.

The main manual gas valve and main power disconnect to the furnace must be properly labeled by the installer in case emergency shutdown is required.

## Leak Check

### ! CAUTION:

Do not use matches, lighters, candles, or other sources of open flame to check for gas leaks.

### ! WARNING:

**FIRE OR EXPLOSION HAZARD**  
Failure to follow the safety warnings exactly could result in serious injury, death or property damage.

Never test for gas leaks with an open flame. Use a commercially available soap solution made specifically for the detection of leaks to check all connections. A fire or explosion may result causing property damage, personal injury or loss of life.

After the gas piping to the furnace is complete, all connections must be tested for gas leaks. To check for leaks use only a soap and water solution or other approved method.

**IMPORTANT NOTE:** When pressure testing gas supply lines at pressures greater than 1/2 psig (14 in. water column), the furnace must be disconnected from the gas supply piping system to prevent damage to the gas control valve. If the test pressure is less than or equal to 1/2 psig (14 in. water column), the furnace must be isolated from the gas supply line by closing the manual shut-off valve.

---

 **WARNING:**

---

**This furnace was equipped at the factory for use with natural gas only. A special kit, supplied by the manufacturer, is required to convert the furnace to operate on LP/propane gas. Failure to use the proper conversion kit can cause fire, explosion, property damage, carbon monoxide poisoning, personal injury, or death.**

---

### **Conversion**

Conversion of this furnace to use LP/propane gas must be made by qualified service personnel, using **only** approved parts.

### **High Altitude Application**

High altitude application with this furnace can be field performed by a simple adjustment of manifold pressure, and if necessary changing the orifices. The changes required depend on the installation altitude and the heating value of the gas. The gas heating value based on sea level can be obtained from your local gas utility. The heating value of gas at high altitude is always lower than the sea level heating value. The heating values used in Table 8 are based on sea level values. Vent pipe lengths listed in Table 6 are decreased 8% per 1,000 ft. of altitude.

### **Natural Gas High Altitude Conversion**

All factory shipped furnaces are ready to operate between zero and 4999 ft. above sea level. For higher altitudes (between 5000 and 10,000 ft. above sea level), conversion can be achieved simply by adjusting the furnace manifold pressure as shown in Table 8.

### **LP/Propane Gas Sea Level and High Altitude Conversion**

Conversion of this furnace to utilize LP/propane gas must be made by qualified service personnel, using factory authorized or approved parts. Conversion to LP/propane gas can be accomplished by first replacing the natural gas orifices with the appropriate LP/propane orifices shown in Table 8. Note: for installations between zero and 5000 ft. above sea level, a #55 drill size orifice should be used. However for installations above 5000 ft. above sea level, a #56 drill size orifice should be used. After changing the orifices, use Table 8 to determine the appropriate manifold pressure for your installation.

Conversion to LP/propane, sea level, and high altitude is detailed in the installation instructions provided with the conversion kit. Approved conversion kits are listed below.

#### *United States LP/Propane Gas Sea Level and High Altitude Conversion Kit - P/N 904090A*

This kit is for LP/propane conversion in the United States at altitudes between zero and 10,000 ft. above sea level. Follow the installation instructions supplied with the kit for proper installation.

#### *Canadian LP/Propane Gas Sea Level and High Altitude Conversion Kit - P/N 904091A*

This kit is for LP/propane conversions in Canada at altitudes between zero and 4500 ft. above sea level. Follow the installation instructions supplied with the kit for proper installation.

---

 **CAUTION:**

---

**To avoid electric shock, personal injury, or death, turn off the power at the disconnect or the main service panel before making any electrical connections.**

---

### **ELECTRICAL WIRING**

Electrical connections must be made in accordance with all applicable local codes and ordinances, and with the current revision of the National Electric Code (ANSI/NFPA 70).

For Canadian installations electrical connections and grounding must be done in accor-

CAPACITY OF BLACK IRON GAS PIPE (CU. FT. PER HOUR) FOR NATURAL GAS (SPECIFIC GRAVITY - 0.60)								
NOMINAL BLACK IRON PIPE DIAMETER (in.)	LENGTH OF PIPE RUN (feet)							
	10	20	30	40	50	60	70	80
1/2	130	90	75	65	55	50	45	40
3/4	280	190	150	130	115	105	95	90
1	520	350	285	245	215	195	180	170
1 1/4	1050	730	590	500	440	400	370	350
1 1/2	1600	1100	890	760	670	610	560	530

The cubic feet per hour listed in the table above must be greater than the cubic feet per hour of gas flow required by the furnace. To determine the cubic feet per hour of gas flow required by the furnace, divide the input rate of the furnace by the heating value of the gas:

$$\text{Cubic Feet Per Hour Required} = \frac{\text{Input To Furnace (Btu/hr)}}{\text{Heating Value of Gas (Btu/Cu. Ft.)}}$$

**Table 7. Capacity of Black Iron Gas Pipe (cu. ft. per hour) for Natural Gas (specific gravity = .60)**

		ELEVATION (FEET ABOVE SEA LEVEL)				
		0-1,999	2,000-4,999	5,000-5,999	6,000-7,999	8,000-10,000
NATURAL GAS	ORIFICE SIZE	45	45	45	45	45
	MAN. PRESSURE (IN W.C.)	3.5	3.5	3.5 ‡	3.0 ‡	2.8 ‡
LP/PROPANE GAS	ORIFICE SIZE	55	55	55	56	56
	MAN. PRESSURE (IN W.C.)	9.5	9.0	8.5	10.0	8.0

‡ = Based on heating value from 900 to 999 BTUH. For heating values less than 900 BTUH multiply manifold pressure by 1.1 for corrected pressure. For heating values greater than 1,000 BTUH, multiply manifold pressure by 0.9 for corrected pressure.

**Table 8. Natural and LP Gas Orifice Sizes and Manifold Pressure**

dance with the current Canadian Electrical Code (CSA C22.1 Part 1) and/or local codes. If any of the original wire as supplied with the furnace must be replaced, it must be replaced with wire having a minimum temperature rating of 105°C. Refer to the furnace nameplate and Table 9 for electrical requirements.

### Line Voltage Wiring

The line voltage (115 volt) to the furnace must be supplied from a dedicated branch circuit containing the correct fuse or circuit breaker for

the furnace. See Table 9. An electrical switch should be readily accessible from and within sight of the furnace. (See the Wiring Diagram label in the furnace and Figure 21.)

The furnace cabinet must have an uninterrupted, unbroken ground to minimize injury should an electrical fault condition occur. The controls used in this furnace require an earth ground to operate properly. Acceptable methods for grounding are electrical wire or conduit approved for electrical ground service. Do not use gas piping as an electrical ground.

**NOTE: Proper line voltage polarity must be maintained in order for the control system to operate correctly. Verify that the incoming neutral line is connected to the white wire and the incoming “hot” line is connected to the black wire in the junction box. These furnaces will not operate unless polarity and ground are properly connected. See Figure 18.**

**⚠ CAUTION:**

**Label all wires prior to disconnection when servicing controls. Wiring errors can cause improper and dangerous operation. Verify proper operation after servicing.**

**Low Voltage Wiring**

Install the thermostat per the manufacturer’s instructions. The low voltage (24 volt) connections from the thermostat are made at the terminal strip on the control board in the furnace. See Figure 19 for the proper connections for heating only (two-wire) and heating/cooling (four-wire) applications. The recommended minimum wire gauge for thermostat wiring is shown in Table 9.

The thermostat must not be installed on an outside wall or any other location where its operation may be adversely affected. Adverse affects include radiant loading from fireplaces, sunlight, or lighting fixtures, and convective

loading from warm air registers or electrical appliances.

To check the heat anticipator setting either:

1. Add the current draw of the system components; or
2. Measure the current flow on the thermostat R-W circuit after the circulating blower motor has started.

Set the heat anticipator according to the thermostat manufacturer’s instructions for heat anticipator settings.

**START-UP AND ADJUSTMENTS**

Prior to start-up, verify that:

1. The line voltage power leads are securely connected, that the polarity of the connections is correct, and that the furnace is properly grounded.
2. The thermostat wires (R, W, Y, and G) are securely connected to the correct leads on the terminal strip of the circuit board.
3. The gas line service pressure does not exceed 10.0 in. water column (0.36 psig), and is not less than 4.5 in. water column (0.16 psig) for natural gas. For LP gas the line service pressure must not exceed 14 in. water column (0.51 psig), and must not be less than 11.0 in. W.C. (0.40 psig).
4. The roll-out and vent safety manual reset switches are closed. If necessary, press the red button to reset a switch. See Figure 22 for location. DO NOT install a jumper wire across a switch to defeat its function.

Furnace Input (Btuh)	Cabinet Width (in.)	Nominal Electrical Supply	Maximum Operating Voltage	Minimum Operating Voltage	Maximum Furnace Amperes	Minimum Wire Gauge	Maximum Fuse or Circuit Breaker Amps*
38,000	14.25	115-60-1	127	103	7.0	14	15
60,000	14.25	115-60-1	127	103	9.5	14	15
80,000	19.75	115-60-1	127	103	11.9	14	15
100,000	19.75	115-60-1	127	103	11.9	14	15
120,000	22.50	115-60-1	127	103	15.8	12	20

\* Time-delay fuses or HACR-type circuit breakers are required.

Thermostat Wire Gauge	Recommended Maximum Thermostat Wire Length	
	2-wire (heating)	4 or 5-wire (cooling)
24	55 ft.	25 ft.
22	90 ft.	45 ft.
20	140 ft.	70 ft.
18	225 ft.	110 ft.

**Table 9. Electrical Data**

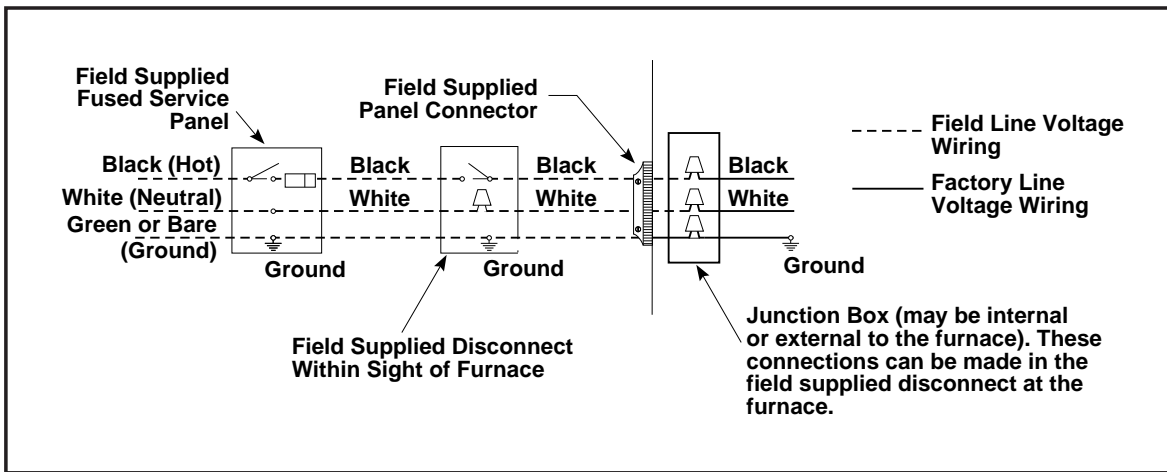

**Figure 18. Line Voltage Field Wiring**

- If a switch reopens on start-up, DO NOT reset the switch without identifying and correcting the fault condition which caused the switch to trip.
- The blower door is in place, closing the door switch in the line voltage circuit.
  - The gas line has been purged and all connections are leak tight.
  - Start the furnace and allow it to run for at least three minutes.
  - Measure the time (in seconds) required for the gas meter to complete one revolution.
  - Convert the time per revolution to cubic feet of gas per hour using Table 10.
  - Multiply the gas flow rate in cubic feet per hour by the heating value of the gas in Btu per cubic foot to obtain the firing rate in Btuh.

### Start-Up Procedure

- Set the thermostat to the lowest setting.
- Close the disconnect(s) to provide line voltage to the furnace.
- Follow the procedures given on the operating instructions label attached to the furnace.
- Set the thermostat above room temperature and verify the sequence of operation. (See the SEQUENCE OF OPERATION.)
- After the furnace has run for approximately five minutes, set the thermostat below room temperature and verify steps (9) through (11) of the SEQUENCE OF OPERATION.

### Verifying and Adjusting Firing Rate

The firing rate must be verified for each installation to prevent over-firing the furnace.

NOTE: The firing rate must not exceed the rate shown on the furnace rating plate. At altitudes above 2000 ft. the firing rate must be adjusted as described in the high altitude section.

Use the following procedure to determine the firing rate:

- Shut off all other gas fired appliances.

- Time for 1 revolution of a gas meter with a 1 cubic foot dial = 40 seconds.
  - From Table 12 read 90 cubic feet per hour of gas.
  - Heating value of the gas (obtained from gas supplier) = 1040 Btu per cubic foot.
  - Firing rate =  $1040 \times 90 = 93,600$  Btuh.
- Adjustments to the firing rate can be made by adjusting the gas manifold pressure. See the High Altitude Application section for additional information of firing rate at elevations above 2000 ft.

The manifold pressure must be set to the appropriate value for your installation. Refer to Table 8 to verify the manifold pressure setting required for your particular installation. To adjust the manifold pressure, remove the brass fitting on the valve. The adjustment screw is located underneath the fitting. Turn the adjustment screw clockwise to increase pressure, or counter clockwise to reduce pressure, and replace the fitting and tubing when adjustments are complete.

The valve is designed with limiting device on the regulator, where the maximum adjustment for natural gas is  $3.50 \pm 0.2$  in w.c., and  $10.0 \pm 0.5$  in w.c. for LP/propane gas

## CAUTION:

**Do not re-drill the burner orifices. If the orifice size must be changed, use only new orifices.**

### Verifying and Adjusting Temperature Rise

Verify that the temperature rise through the furnace is within the range specified on the furnace rating plate. Temperature rises outside the specified range could result in premature heat exchanger failure.

Place thermometers in the return and supply air stream as close to the furnace as possible. The thermometer on the supply air side must be shielded from direct radiation from the heat exchanger to avoid false readings. Adjust all registers and duct dampers to the desired position and run the furnace for fifteen minutes before taking any temperature readings. The temperature rise is the difference between the supply and return air temperatures.

For typical duct systems, the temperature rise will fall within the range specified on the rating plate with the blower speed at the factory recommended setting. If the temperature rise measured is outside the range specified, it may be necessary to change the blower speed. Lower blower speeds will increase the temperature rise and higher blower speeds will decrease the temperature rise.

The furnace is equipped with a multispeed motor. Heating and cooling speed selection is made by moving the leads on the integrated control board located in the furnace. The wiring diagram on the furnace and Figure 21 shows the speed taps for adjusting motor speed.

If it is desired that the blower operate at the same speed for heating and cooling, tape off the terminal of the unused blower wire or place on M1, M2 or M3 terminals on the control board. Install the jumper wire, found in the plastic instruction bag, across the HEAT and COOL taps on the control board. Reconnect the desired blower tap to the piggyback quick connect.

The blower control is designed to start the circulating air blower 30 seconds after the gas valve is opened. The blower control is factory wired to turn the blower motor off 120 seconds

after the gas valve is closed. This timing can be changed using the BLOWER OFF timing switch opposite the terminal block on the control board. (See Figure 20.)

### Verifying Burner Operation

To verify operation of the burners, make sure that the blower compartment door is in place and that there is power to the furnace. Set the thermostat above room temperature and observe the ignition sequence. The flame can be observed through the small clear window on the burner box. The burner flame should carry over between all burners. The flames should be blue, without yellow tips. Flames should extend from each burner without lifting, curling, or floating. After verifying ignition, set the thermostat below room temperature and verify that the burner flame extinguishes completely.

### Verifying Operation of the Supply Air Limit Switch

To verify operation of the supply air limit switch, make sure that the blower door is in place and that there is power to the furnace. Completely block the return airflow to the furnace by installing a close-off plate in place of or upstream of the filter(s). Set the thermostat above room temperature and verify that the Sequence of Operation is as described in these instructions. The supply air limit switch should function to turn off the gas valve within approximately five minutes. The circulating air and combustion blowers should continue to run when the supply air limit

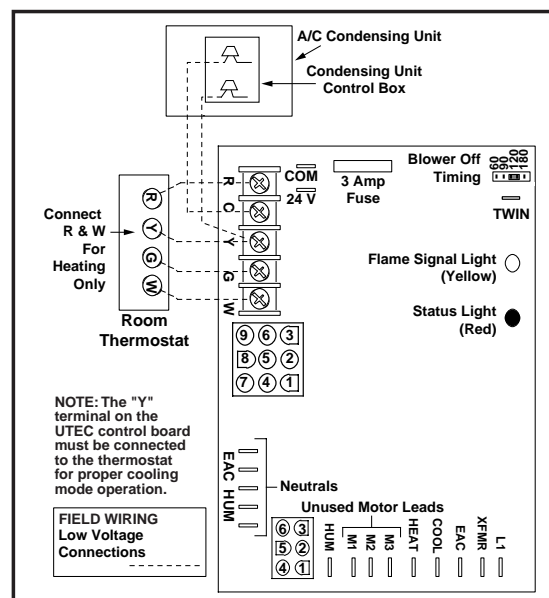

**Figure 19. Low Voltage Field, Four-wire Heating/Cooling Applications**

switch opens. Remove the close-off plate immediately after the supply air limit switch opens. If the furnace operates for more than five minutes with no return air, set the thermostat below room temperature, shut off the power to the furnace, and replace the supply air limit switch.

## DESCRIPTION OF COMPONENTS

Figure 22 shows the location of each of the functional components described below. If any component of the furnace must be replaced, use only factory authorized replacement parts. See the Replacement Parts List for each component.

**Flame Sensor** – The flame sensor acts to prove that flame has carried over from the igniter to the opposite end burner. If no flame is sensed, the furnace will be shut down automatically.

**Gas Valve** – The gas valve controls the flow of gas to the burners. When the gas valve is energized it automatically opens and regulates the gas pressure in the manifold.

**Pressure Switch** – The pressure switch verifies that the inducer is drawing the combustion

gases through the heat exchanger. It also senses a blocked condensate drain condition.

**Vent Pressure Switch** – The vent pressure switch reacts to blockage in the vent or combustion air piping.

**Supply Air Limit Switch** – The supply air limit switch prevents the air temperature leaving the furnace from exceeding the maximum outlet air temperature.

**Flame Roll-Out Switch** – This switch provides flame roll-out protection to the furnace and combustion air inlet pipe.

## MAINTENANCE

It is recommended that the furnace be checked yearly. At a minimum, this check should include the following items.

### **WARNING:**

**To avoid electric shock, personal injury, or death, disconnect the electric power before performing any maintenance.**

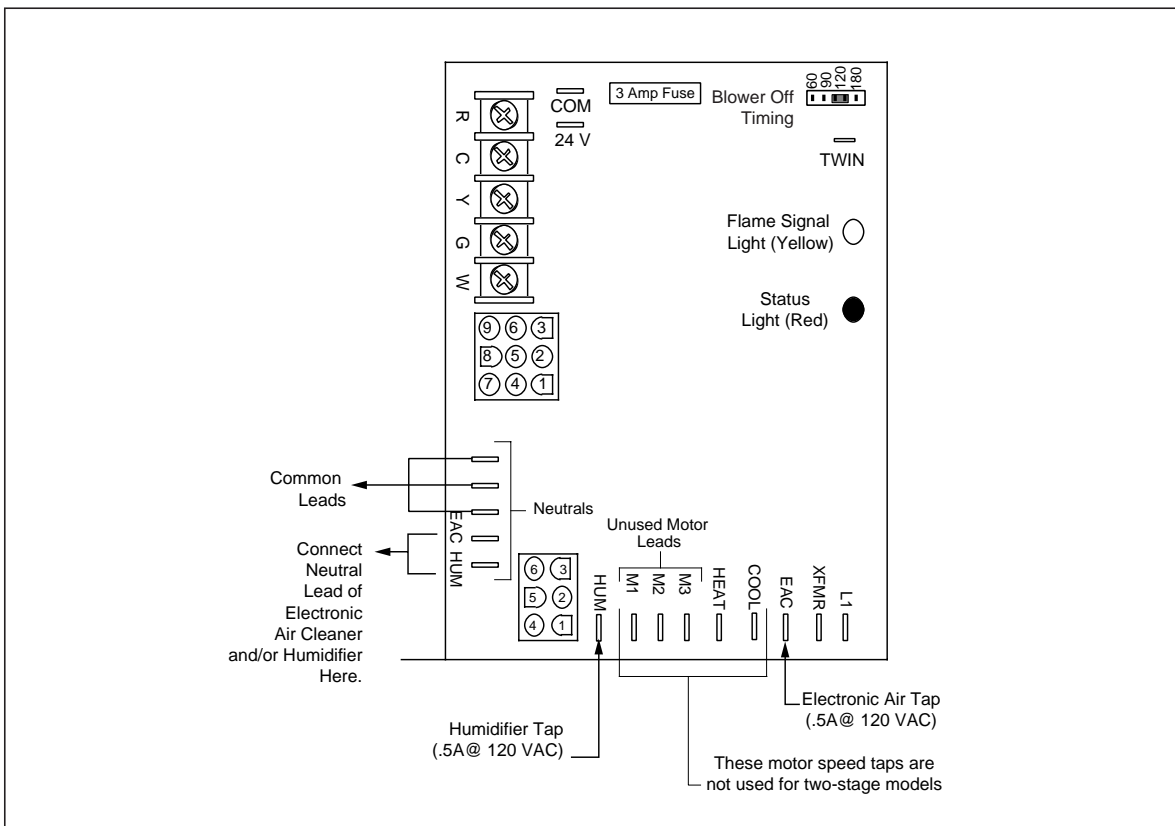

**Figure 20. Blower Speed Tap Location**

GAS FLOW RATE (CUBIC FEET PER HOUR)							
TIME FOR ONE REVOLUTION (SECONDS)	CUBIC FEET PER REVOLUTION OF METER			TIME FOR ONE REVOLUTION (SECONDS)	CUBIC FEET PER REVOLUTION OF METER		
	1	5	10		1	5	10
24	150	750	1500	80	45	225	450
26	138	692	1385	82	44	220	439
28	129	643	1286	84	43	214	429
30	120	600	1200	86	42	209	419
32	113	563	1125	88	41	205	409
34	106	529	1059	90	40	200	400
36	100	500	1000	92	39	196	391
38	95	474	947	94	38	191	383
40	90	450	900	96	38	188	375
42	86	429	857	98	37	184	367
44	82	409	818	100	36	180	360
46	78	391	783	102	35	176	353
48	75	375	750	104	35	173	346
50	72	360	720	106	34	170	340
52	69	346	692	108	33	167	333
54	67	333	667	110	33	164	327
56	64	321	643	112	32	161	321
58	62	310	621	114	32	158	316
60	60	300	600	116	31	155	310
62	58	290	581	118	31	153	305
64	56	281	563	120	30	150	300

Table 10. Gas Flow Rate

**! WARNING:**

Holes in the vent pipe or heat exchanger can cause products of combustion to enter the home. Replace the vent pipe or heat exchanger if leaks are found. Failure to prevent products of combustion from being circulated into the living space can create potentially hazardous conditions including carbon monoxide poisoning that could result in personal injury or death.

**Combustion Air and Vent System**

Check the combustion air and vent pipe to ensure that it is not damaged, corroded or blocked by debris. Any damaged section of vent pipe must be replaced, and any obstruction or blockage must be removed prior to operating the furnace.

**Air Filter(s)**

**! WARNING:**

Never operate the furnace without a filter in place. Dust and lint in the return air can build up on internal components, resulting in loss of efficiency, equipment damage, and possible fire.

AIR FILTER(S) ARE NOT SUPPLIED WITH THE FURNACE AS SHIPPED FROM THE FACTORY. FILTERS FOR SIDE RETURN AND BOTTOM RETURN APPLICATIONS ARE AVAILABLE FROM YOUR LOCAL DISTRIBUTORS.

The installer should provide a filter rack for a high velocity type filter in the return air duct adjacent to the furnace. Filters should be changed or cleaned monthly during the heating season. New or newly renovated homes may require more frequent changing.

**Lubrication**

The bearings in the circulating air blower motors are pre-lubricated and sealed at the factory. No further oiling of the bearings is required for the life of the motor.

**Condensate Drain Assembly**

Be sure the condensate lines are free and open (i.e. avoid kinking hoses). Also make sure all hose clamps are tight to avoid drawing air into the system.

**Blower Compartment**

The blower compartment should be cleaned monthly during the heating and cooling seasons to remove any dirt and lint that may have accumulated in the compartment or on the blower and motor. Dirt and lint can create excessive loads on the motor resulting in higher

than normal operating temperatures and shortened service life.

### Heat Exchanger and Burner Maintenance

The furnace should operate for many years without excessive soot buildup in the flue passageways, however, the flue passageways, the vent system, and the burners should be inspected and cleaned (if required) by a qualified serviceman annually to ensure continued safe operation. Particular attention must be given to identify deterioration from corrosion or other sources.

## SYSTEM OPERATION INFORMATION

Proper maintenance is most important to achieve the best performance from a furnace. Follow these instructions for years of safe, trouble free operation.

- **Do not place combustible materials on or against the furnace cabinet or the vent pipe.**
- **Do not store gasoline or any other flammable vapors and liquids in the vicinity of the furnace.**
- **Change or replace the air filters monthly during any period when the circulating blower is operating regularly.**
- **Always replace the doors on the furnace after servicing. Do not operate the furnace without all doors and covers in place.**
- **Avoid operating the furnace when windows and doors are open.**
- **Be sure that the thermostat is properly installed and is not being affected by drafts or heat from lamps or other appliances.**

### Sequence of Operation

Operating sequences for the heating, cooling, and fan modes are described below. Refer to the wiring diagrams (Figures 21) and the voltage field wiring diagram (Figure 19.)

#### Heating Mode:

1. On a call for heat the thermostat closes, applying 24 VAC to the W terminal on the control board.

2. The control board checks for continuity on the 24 VAC limit control circuit (over-temperature limit switch, flame rollout switches and blocked vent switch in series). If an open limit is detected the control board will energize the inducer and the conditioned air blower. All other system functions will be inoperable until the limit circuit closes. While the limit is open, the red LED will blink continuously.
3. The furnace control checks for continuity across the pressure switch (24 VAC). If the pressure switch is closed the heat mode sequence will not continue. If it remains closed for 10 seconds the red LED will blink 3 times repetitively until the fault condition clears.
4. The inducer is energized.
5. The pressure switch will close. If the pressure switch does not close after 10 seconds the fault LED will blink 2 times repetitively and the inducer will continue to run until the switch is closed.
6. The inducer will pre-purge for 30 seconds and then the igniter will start its warm-up as follows:  
Initial Power up: After 30 seconds of igniter warm-up the gas valve (24 VAC) will then open. The igniter circuit will stay energized for 3 seconds after the gas valve opens.  
After Initial Power up: The control has a programmed adaptive ignition feature which varies the warm-up period as follows: If ignition is successful the warm-up is reduced by 3-seconds on each subsequent call for heat until ignition failure occurs. Upon ignition failure, the warm-up is increased by 3-seconds on the next try. If successful, the timing remains fixed at this level. In general, whenever ignition failure occurs the warm-up interval is increased by 3-seconds on the next try. And if successful, it remains there. Minimum and maximum warm-up time limits are set at 6 and 54-seconds, respectively.
7. The furnace control must prove flame via the flame, the flame sensor 5 seconds after the gas valve opens. If flame is sensed, all burners are on and the igniter cools off. If no flame is sensed, the gas valve closes immediately and the inducer continues to run. A second trial for ignition (step 6) begins if no flame is sensed. On the fifth try

# For Upflow and Downflow Residential Furnaces

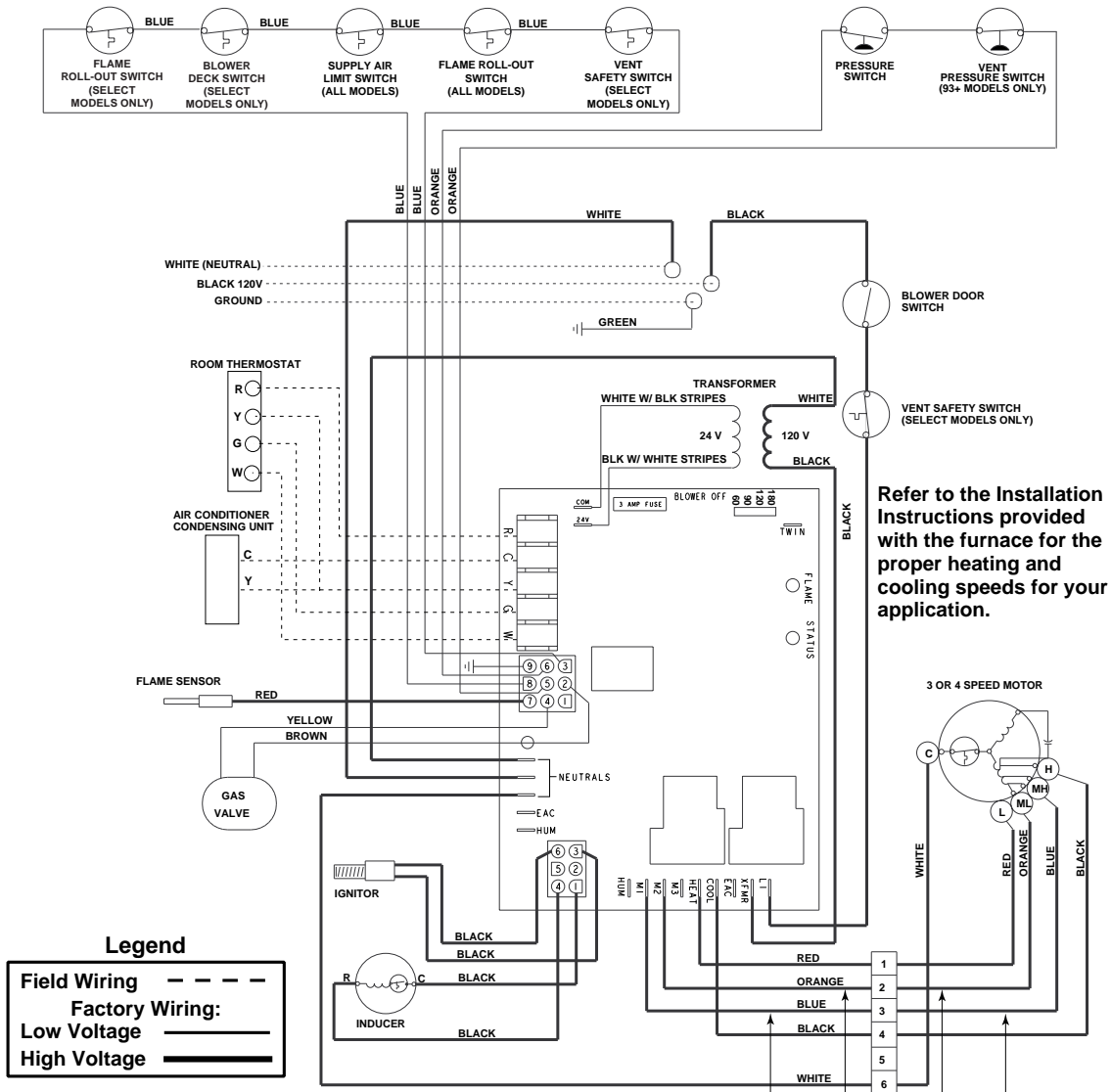

Refer to the Installation Instructions provided with the furnace for the proper heating and cooling speeds for your application.

**Legend**

Field Wiring - - - - -  
 Factory Wiring: \_\_\_\_\_  
 Low Voltage - - - - -  
 High Voltage \_\_\_\_\_

FAULT CONDITION	STATUS RED LIGHT
Power On	ON
Limit Circuit Open or External Load On "W"	1 FLASH
Pressure Switch is Open with Inducer On	2 FLASHES
Pressure Switch is Closed with Inducer Off	3 FLASHES
Ignition Failure (Check Ground)	4 FLASHES
115 VAC & Neutral Reversed or no Ground	5 FLASHES
False Flame or Gas Valve Relay Shorted	Continuous
Power Off	OFF

FAULT CONDITION	FLAME YELLOW LIGHT
Low Flame Sensor Signal	Continuous Flash
Flame Present	ON

These wires are not present on all models

If any of the original wire as supplied with the furnace must be replaced, it must be replaced with wiring material having a temperature rating of at least 105 C.

WD# 7103550

Figure 21. Wiring Diagram

## Upflow Furnace Models

- 1 Igniter (Not Shown)
- 2 Flame Sensor (Not Shown)
- 3 Gas Valve
- 4 Flame Roll-out Switch(s)
- 5 Pressure Switch
- 6 Vent Pressure Switch (Not Shown)
- 7 Control Board
- 8 Blower Door Switch
- 9 Vent Safety Switch
- 10 Low Voltage Transformer
- 11 Supply Air Limit Switch
- 12 Circulating Air Blower Assembly-
- 13 Induced Draft Blower
- 14 Condensate Drain Tube
- 15 In-Line Drain Assembly
- 16 Burner View Port
- 17 Front Header Box
- 18 Combustion Air Intake
- 19 Exhaust Vent

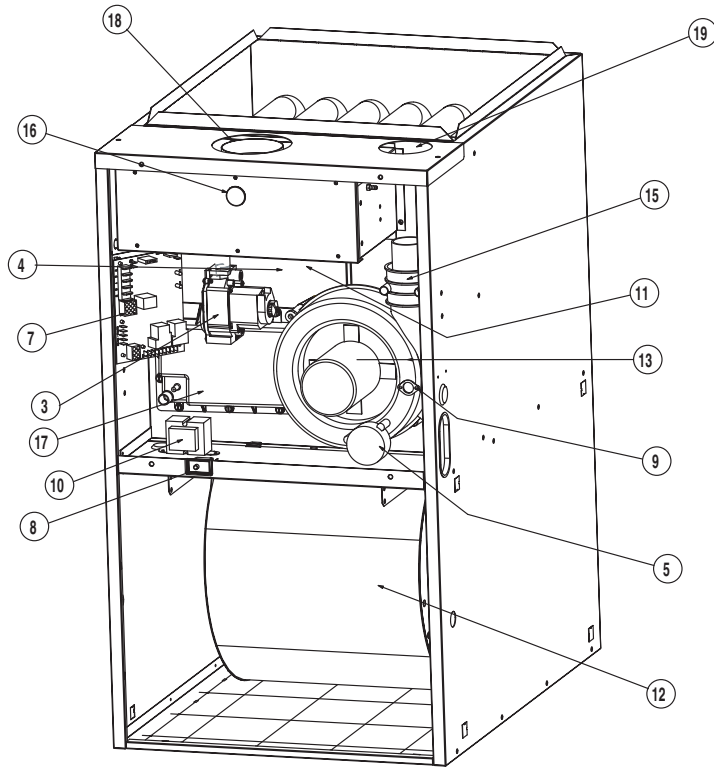

**Figure 22. Location of Major Components**

for ignition, the furnace control is locked out and the red LED will blink 4 times repetitively. The thermostat must be opened for at least ten seconds to reset the furnace control after a lock out. Otherwise, the furnace will attempt another ignition sequence in 1 hour.

8. The furnace control energizes the circulating air blower on the heating speed 30 seconds after the gas valve circuit is energized .
9. When the thermostat has been satisfied, gas valve is de-energized.
10. The inducer is de-energized after a 30 second postpurge.
11. The furnace control keeps the circulating air blower energized for 120 seconds (factory set) or 60, 90, or 180 seconds (field adjustable). (See Figure 20.)
12. Abnormal conditions: If a limit opens during operation, the inducer and circulating air blower continue to operate. The gas valve

is de-energized immediately. The blowers continue to operate until the limit closes. When the limit closes the inducer blower is de-energized immediately. The circulating air blower continues to operate for the specified delay (factory set at 120 seconds).

### *Cooling Mode:*

1. On a call for cooling the thermostat closes, applying 24 VAC to the G and Y terminals on the furnace control. This closes the compressor contactor.
2. The furnace control energizes the circulating blower (115 VAC) on the cooling speed.
3. When the thermostat is satisfied, the G and Y terminals on the control board are de-energized opening the compressor contactor.
4. The circulating air blower is de-energized after a 90 second delay.

*Fan Mode:*

1. On a call for fan operation, the thermostat applies 24 VAC to the G terminal on the furnace control board.
2. The circulating air blower is energized immediately on the heating speed.
3. If the furnace is operated in the continuous ON position at the thermostat and is then switched to AUTO, the circulating blower will operate for a specified delay (factory set at 120 seconds).

### Furnace Fails to Operate

If the furnace does not operate check the following:

1. Is the thermostat operating properly?
2. Are the blower compartment door(s) in place?
3. Is the furnace disconnect closed?
4. Has the circuit breaker tripped or the control board fuse burned open?
5. Is the gas turned on?
6. Are any manual reset switches open?
7. Is the filter dirty or plugged?
8. Is the flame sensor coated? (Remove and clean with emery cloth.)

If the furnace locks out after 5 attempts for ignition, it will try again every hour if a call for heat remains. If the inducer and circulating air blowers are operating, and items 1 through 8 have been checked, press the red reset button on the vent safety switch. (See Figure 22.) If the furnace operates after depressing the reset button, contact a qualified serviceman to identify and repair the problem.

If the furnace continues to not operate, depress the red reset buttons on the flame rollout switches. (See Figure 22.) If the furnace operates after depressing the reset buttons, contact a qualified servicemen to identify and repair the problem.

### Twining of Two Furnaces

The control board on these furnaces is capable of being twinned to another furnace of the same series, provided the circuit boards are both UTEC type. If using UTEC control boards, leave the fuses installed on each board. The thermostat wires and the 1/4 inch quick-connect terminals marked "TWIN" on the furnace controls must be connected together for twinning. (See Figure 23.)

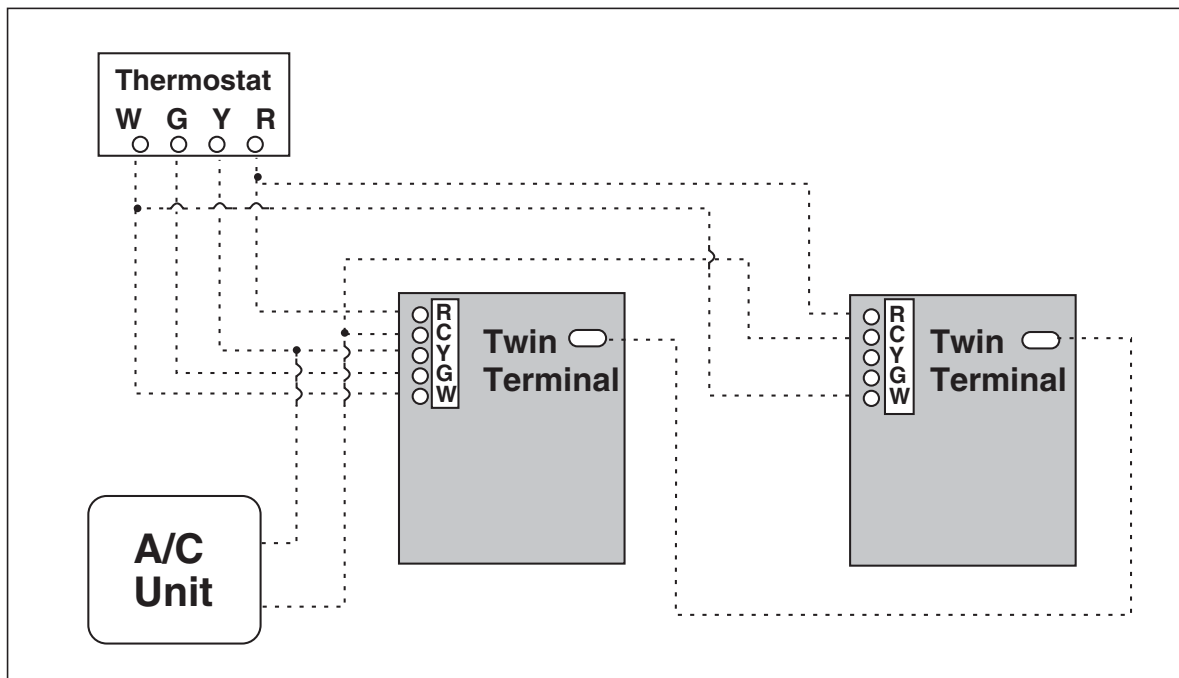

Figure 23. Twining

# INSTALLATION/PERFORMANCE CHECK LIST

LOCATION \_\_\_\_\_ CITY \_\_\_\_\_ STATE \_\_\_\_\_

INSTALLER \_\_\_\_\_ CITY \_\_\_\_\_ STATE \_\_\_\_\_

UNIT MODEL # \_\_\_\_\_ UNIT SERIAL # \_\_\_\_\_

Minimum Clearances per Table 3? \_\_\_\_\_ Supply Air Temperature: \_\_\_\_\_ (° F)

Electrical Connections tight? \_\_\_\_\_ Return Air Temperature: \_\_\_\_\_ (° F)

Line Voltage Polarity correct? \_\_\_\_\_ Temperature Rise: \_\_\_\_\_ (° F)

Supply Voltage: \_\_\_\_\_ Volts Are Flue Connections tight? \_\_\_\_\_

Blower Motor HP: \_\_\_\_\_ Is there Proper Draft? \_\_\_\_\_

FUEL TYPE: Is Vent free from restrictions? \_\_\_\_\_

Natural Gas \_\_\_\_\_ LP/Propane \_\_\_\_\_ Is the Filter(s) secured in place? \_\_\_\_\_

Gas Piping Connections leak-tested? \_\_\_\_\_ Is the Filter(s) clean? \_\_\_\_\_

Gas Line Pressure: \_\_\_\_\_ Has the Thermostat been calibrated? \_\_\_\_\_  
(in. water column, with furnace operating) Is the Thermostat level? \_\_\_\_\_

Manifold Pressure: \_\_\_\_\_ Is the Heat Anticipator Setting correct? \_\_\_\_\_  
(in. water column, with furnace operating)

Is there adequate fresh air supply for combustion and ventilation? \_\_\_\_\_ Has the Owner's Information been reviewed with the home-owner? \_\_\_\_\_

Furnace Input: \_\_\_\_\_ (Btuh) Has the Literature Package been left near the furnace? \_\_\_\_\_



7083720