

# USER'S MANUAL & INSTALLATION INSTRUCTIONS

13 SEER

## Single Package Heat Pump

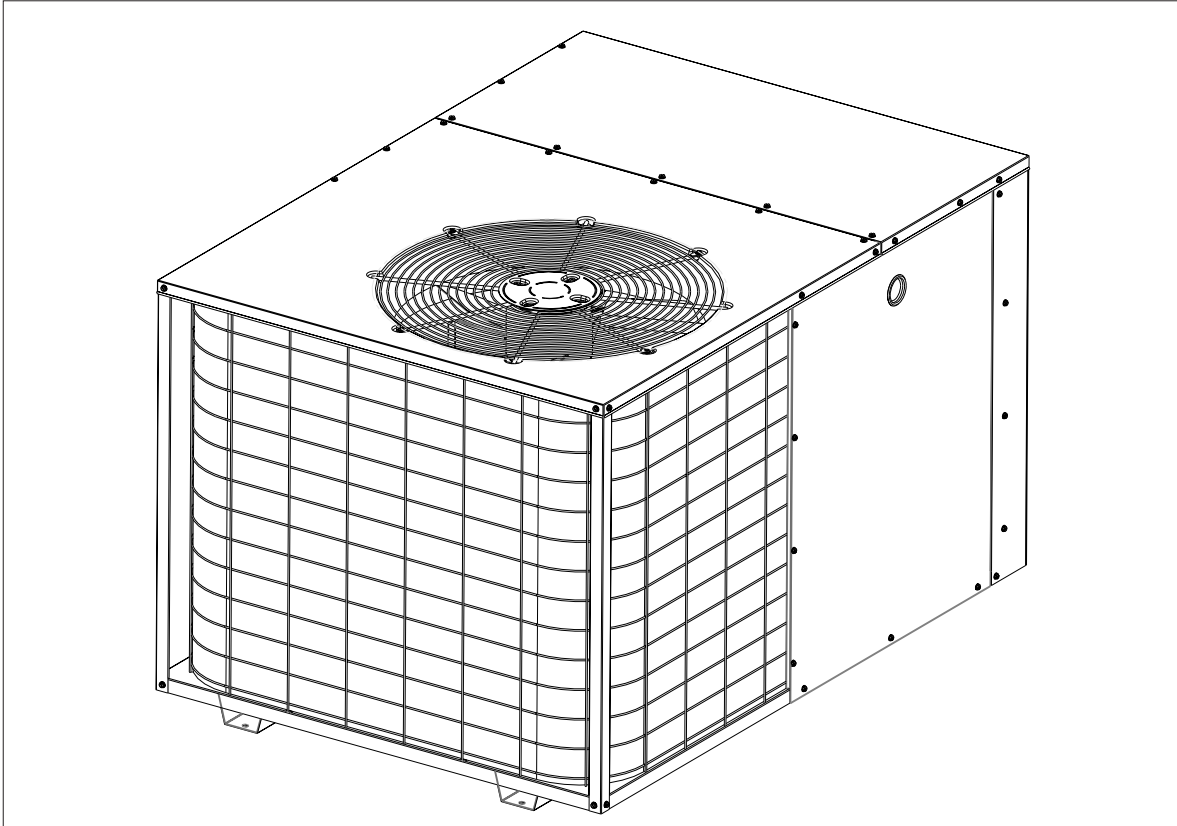

Single Package Heat Pump

---

### **IMPORTANT:**

---

Read this owner information to become familiar with the capabilities and use of your appliance. Keep this with literature on other appliances where you have easy access to it in the future. If a problem occurs, check the instructions and follow recommendations given. If these suggestions don't eliminate your problem, call your installing contractor or distributor in your area.

---

### INTRODUCTION

Your heat pump is a unique, all weather comfort-control system appliance. The basic operation of the heating/cooling system is described and illustrated on page 1 of this manual. The surprising fact that heat exists in air even at below-freezing temperatures is actually the basic law of physics which the heat pump uses to provide energy saving heating comfort. At outdoor temperatures of 47° Fahrenheit (or 8° Celsius), your heat

pump can deliver approximately 2 to 3 units of heat energy per each unit of electrical energy used, as compared to a maximum of only 1 unit of heat energy produced with conventional heating systems. During the cooling season, the heat pump reverses the flow of the heat-absorbing refrigerant to become an energy-efficient, central air conditioner.

---

## SECTION 1. OWNER INFORMATION

Your heat pump will heat and cool your home year round, saving your energy dollars. During the summer, a heat pump performs like any normal air conditioner. That is, the excess heat energy inside the home is absorbed by the refrigerant and exhausted outside the home. During the winter months, a heat pump performs like an air conditioner run in reverse. That is, available heat energy outside the home is absorbed by the refrigerant and exhausted inside the home. This is an efficient heating means because you only pay for “moving” the heat from the outdoors to the indoor area. You do not pay to generate the heat, as is the case with more traditional furnace designs.

It is the sole responsibility of the homeowner to make certain that the heat pump has been correctly set up and adjusted to operate properly.

The manufacturer warrants the heat pump to be free from defects in workmanship or material for a period of one year. A warranty certificate with full details is included with the heat pump. However, we will not be responsible for any costs found necessary to correct problems due to improper setup, improper installation, adjustments, improper operating procedure on the part of the user, etc.

Some specific examples of service calls which are not included in the limited warranty are:

1. Correcting wiring problems in the electrical circuit supplying the heat pump.
2. Resetting circuit breakers or other switches.
3. Adjusting or calibrating of thermostat.

To avoid misunderstandings at a later date, carefully review these responsibilities with your dealer or service company.

### OPERATING INSTRUCTIONS

#### To Operate Your Heat Pump For Cooling —

1. Set the thermostat system switch to COOL and the thermostat fan switch to AUTO. (See Figure 1)
2. Set the thermostat temperature selector to the desired cooling temperature. The outdoor unit fan, the indoor blower, and the compressor will all cycle on and off to maintain the indoor temperature at the desired cooling level.

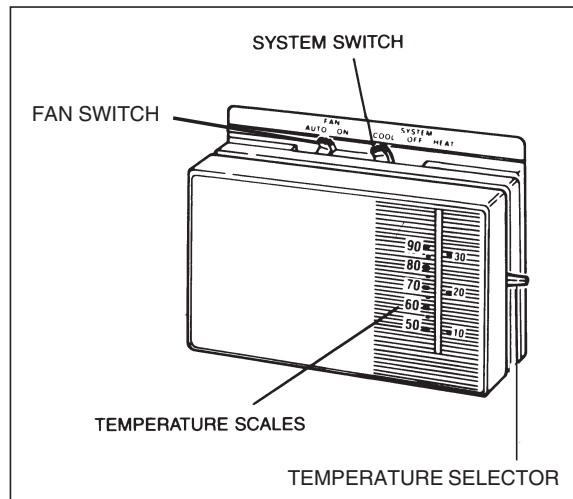

Figure 1. Typical Thermostat

NOTE: If the thermostat temperature level is re-adjusted, or if the thermostat system switch is re-positioned, the outdoor unit fan and the compressor may not start immediately. A protective timer circuit holds the compressor and the outdoor fan off for approximately five minutes following a previous operation or the interruption of the main electric power.

#### To Operate Your Heat Pump For Heating —

1. Set the thermostat system switch for HEAT and the thermostat fan switch to AUTO. (See Figure 1)
2. Set the thermostat temperature selector to the desired heating temperature. The outdoor unit fan, the indoor blower, and the compressor will all cycle on and off to maintain the indoor temperature at the desired heating level.

NOTE: If the thermostat temperature level is re-adjusted, or if the thermostat system switch is re-positioned, the outdoor unit fan and the compressor may not start immediately. A protective timer circuit holds the compressor and the outdoor fan off for approximately five minutes following a previous operation or the interruption of the main electrical power.

**Emergency Heat** — Some thermostats will include a system switch position termed EM HT or AUX HT, etc. This is a back-up heating mode to be used only if there is a suspected problem. With the system switch set to EM HT, etc., the compressor and outdoor fan will be locked off and supplemental heat (electric resistance

heating) will be used as a source of heat. Sustained use of electric resistance heat in place of the heat pump will result in an increase in electric utility costs.

**Defrost** — During cold weather heating operation, the outdoor unit will develop a coating of snow and ice on the heat transfer coil. This is normal and the unit will periodically defrost itself. During the defrost cycle, the outdoor fan will stop, while the compressor continues to run and heat the outdoor coil, causing the snow and ice to melt. During defrost, there may be some steam rise from the outdoor unit as the warm coil causes some melted frost to evaporate.

## SECTION 2. INSTALLER INFORMATION

### GENERAL

**Read the following instructions completely before performing the installation.**

These instructions are for the use of qualified personnel specially trained and experienced in the installation of this type of equipment and related system components. Some states require installation and service personnel to be licensed. Unqualified individuals should not attempt to interpret these instructions or install this equipment.

The single packaged air conditioners are designed for outdoor installation only and can be readily connected into the high static duct system of a home. The only connections needed for installation are the supply and return ducts, the line voltage, and thermostat wiring. A complete air conditioning system typically consists of:

- Single Package Heat Pump
- Home Fittings Kit
- Unit Fittings Kit
- Thermostat

The single package air conditioner is completely assembled, factory wired, and factory run tested. The units are ready for easy and immediate installation.

Use of components other than those specified may invalidate ARI Certification, Code Agency Listing, and limited warranty on the air conditioner.

### PRE-INSTALLATION CHECK

Before any installation is attempted, the cooling load of the area to be conditioned must be

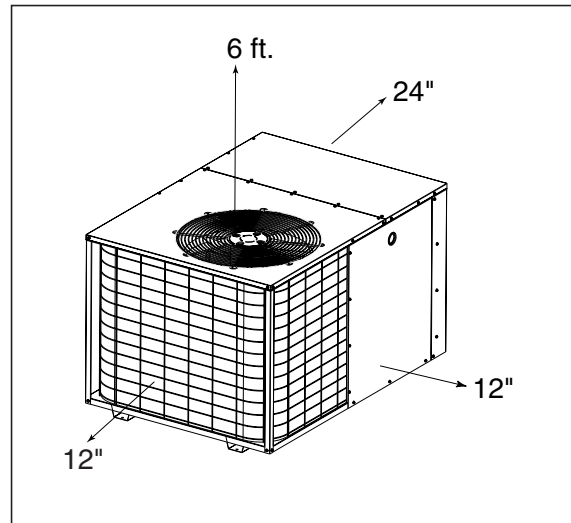

**Figure 2. Minimum Unit Clearances**

calculated and a system of the proper capacity selected. It is recommended that the area to be conditioned be completely insulated and vapor sealed.

The installer should comply with all local codes and regulations which govern the installation of this type of equipment. Local codes and regulations take precedence over any recommendations contained in these instructions. Consult local building codes and the National Electrical Code (ANSI C1) for special installation requirements.

The electrical supply should be checked to determine if adequate power is available. If there is any question concerning the power supply, contact the local power company.

**Inspecting Equipment:** All units are securely packed at the time of shipment and, upon arrival, should be carefully inspected for damage. Claims for damage (apparent or concealed) should be filed immediately with the carrier.

### INSTALLATION

#### 1. SELECT THE BEST LOCATION FOR THE HEAT PUMP UNIT

**IMPORTANT: DO NOT PLACE UNIT UNDER THE HOME.**

- Select a solid, level position, preferably on a concrete slab, slightly above the grade level, and parallel to the home.
- The hot condenser air must be discharged up and away from the home, and if possible, in a direction with the prevailing wind.

- Do not place the unit in a confined space.
- If practical, place the heat pump where it and the ducts will be shaded from the afternoon sun when the heat load is greatest.
- Try to select a site for the unit that is as close as possible to the proposed return grille location.
- Keep in mind that the length of the supply and return ducts should be kept to a minimum with no sharp radiused bends.

## 2. UNPACK THE UNIT

It is recommended that the unit be unpacked at the installation site to minimize damage due to handling.

### **! CAUTION:**

**Do not tip the unit on its side. Oil may enter the compressor cylinders and cause starting trouble. If unit has been set on its side, restore to upright position and do not run for several hours. Then run unit for a few seconds. Do this three or four times with five minutes between runs.**

- Remove the bands from around the unit.
- Unfold the top and bottom cap flanges.
- Carefully remove the top cap and tube.

## 3. INSTALL THE RETURN AND SUPPLY AIR FITTINGS ON THE UNIT

The supply and return fittings are included with select models. If supplied, the duct fittings are

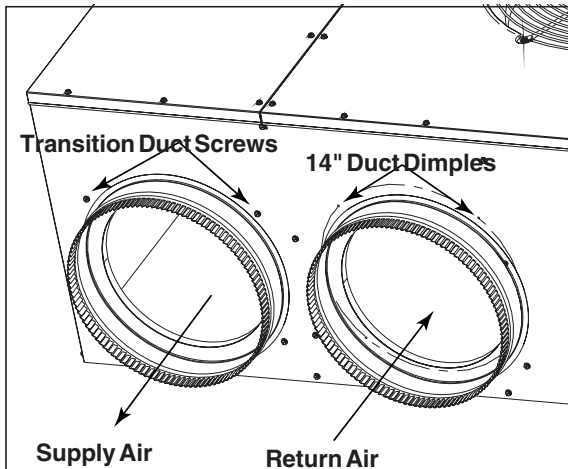

Figure 3. Return and Supply Air Fittings

shipped in the supply duct. They attach to the unit openings with a flange and bead arrangement, secured with two sheet metal screws. Note: For ease of access, install fitting before positioning unit in final location.

### SUPPLY DUCT

Position the supply duct collar, if supplied, so the edge of the unit opening fits between the flange and the bead. Overlap the collar ends keeping the small screw holes underneath. Align the holes in the crimped area and install one screw.

Note: It may be necessary to loosen the four screws that hold the transition duct in order to install the supply fitting. Re-tighten when installation is complete.

Tap collar as necessary to ensure engagement with unit opening and install second screw. Tighten first screw. Rotate collar clockwise so joint is near three o'clock position.

### RETURN DUCT

The 12" return duct is installed in the same manner as the supply duct. If the duct has a 14" return, follow these instructions.

Align the slots with the holes in the collar and install two screws. Position the collar over the opening and align the four notches in the collar with the four dimples in the panel. Using self-drilling screws (10-16x.5) attach the collar to the rear panel. On some models a 14" duct collar is provided for the return duct.

## 4. LOCATING AND INSTALLING THE RETURN AIR ASSEMBLY

To avoid complications, locate and install the return air assembly first. The return air box with grille and filter (Figure 4) should not be located in heavy traffic areas like hallways or center of rooms. A good spot is in a corner or under a table, if a minimum two inch clearance is available. If desired, the return opening can be

13 SEER	Return Dia. (in)
2 Ton	12
2 1/2 Ton	14
3 Ton	14
3 1/2 Ton	14
4 Ton	14

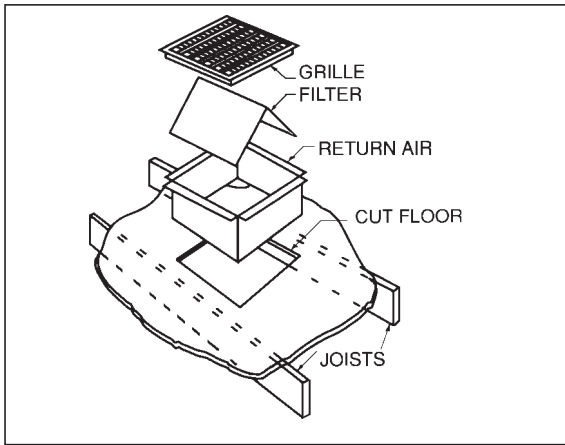

**Figure 4. Return Air Box**

located inside a closet with louvered doors that have an open area equal to or greater than the 12" x 20" grille furnished. The return air grille can be placed in the wall of a closet and the air ducted into the filter box through a boxed-in area at the closet floor level. Make sure the filter is readily accessible.

After determining the location of the return air opening, start the installation from under the home by cutting a small hole in the fiber underboard to determine how the floor joist location will affect cutting the opening needed for the box. Floor joists generally are located on 16" centers, leaving 14-3/8" between joists. After measuring the return air box (approximately 12-1/4" x 20-1/4"), cut the hole through the floor so that the box will fit between the floor joists. Care should be taken when cutting through carpeting to avoid snags. In most installations it will be necessary to cut a similar hole in the fiberboard directly under the hole in the floor. However, if the floor is more than ten inches deep, it will only be necessary to cut a hole for the collar on the return air box or for the insulated duct.

Set the box into the opening and fasten with screws or nails. Put the filter and return air grille in place.

## 5. LOCATING AND INSTALLING THE SUPPLY DAMPER(S)

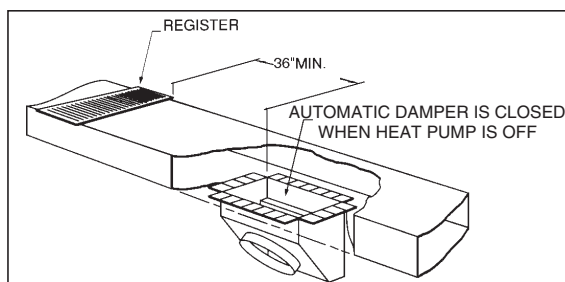

**Figure 5. Supply Damper**

When locating the supply damper(s), carefully check floor joists and frame members that could interfere with the installation of the damper or flexible duct. Ideally, the damper should be located in the bottom of the main duct, forward of center of the home, at least three feet from the nearest register. The round supply opening in the slanted side of the damper should face the side of the home where the heat pump is located. To locate the center of the heat duct, first cut a small hole in the fiberboard below the duct at the desired location. After locating the duct center, cut a hole approximately 3/4" larger than the damper opening in the fiberboard. Cut a 9-1/8" x 13-1/8" hole in the duct and bend over all tabs flat on the inside of the heat duct. After inserting the damper into the duct, bend over all tabs flat on the inside of the heat duct. Seal the opening between the fiberboard and damper or flexible duct.

## DUCTING SYSTEM

### DUCT REQUIREMENTS

The supply duct system, including the number and type of registers, will have much more effect on the performance the system than any other factor. The duct must be sufficiently large to conduct an adequate amount of air to each register.

**THE HEAT PUMP SYSTEM WILL NOT COOL OR HEAT THE HOME IF THE AIR IS LOST TO THE OUTSIDE THROUGH LEAKS IN THE DUCT SYSTEM. ALSO, DUCTS WHICH ARE COLLAPSED OR RESTRICTED BY FOREIGN OBJECTS WILL PREVENT ADEQUATE AIR FLOW.**

Note: For highly resistive duct systems it may be necessary to add an additional return air duct to achieve maximum performance.

### CONNECTING THE RETURN AND SUPPLY AIR FLEXIBLE DUCTS

The return duct may be 12" or 14" diameter depending on unit size. (See Table on page 4)

- The supply duct for all units is twelve inches in diameter.
- The flexible ducts can be connected to the corresponding fittings with the clamps provided with the ducts. Note: All connections should be leak tight or a loss in cooling capacity will result.

- c. The flexible ducts may be cut to the required length, see instructions packed with duct. Keep all ducts as short and straight as possible. Avoid sharp bends.
- d. Ducts may be spliced with sheet metal sleeves and clamps. (See Ducting Installation Accessories below.)
- e. Once the inner duct is connected to the proper fitting, the insulation and plastic sleeve should be pulled over the connection and clamped.
- f. For homes with multiple supply ducts or for special applications, a Y fitting is available to divide the supply air so it can be ducted to different areas of the home for more efficient cooling. Note: The Y fitting should be insulated for maximum performance.

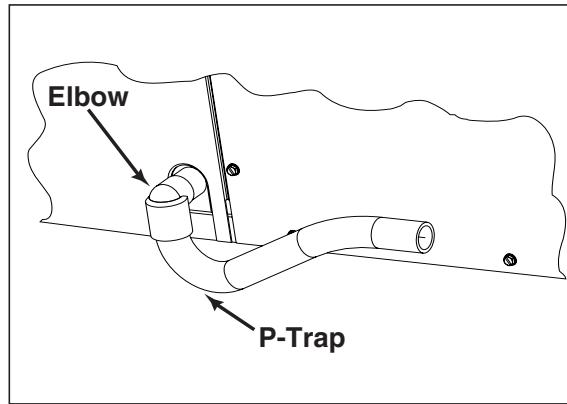
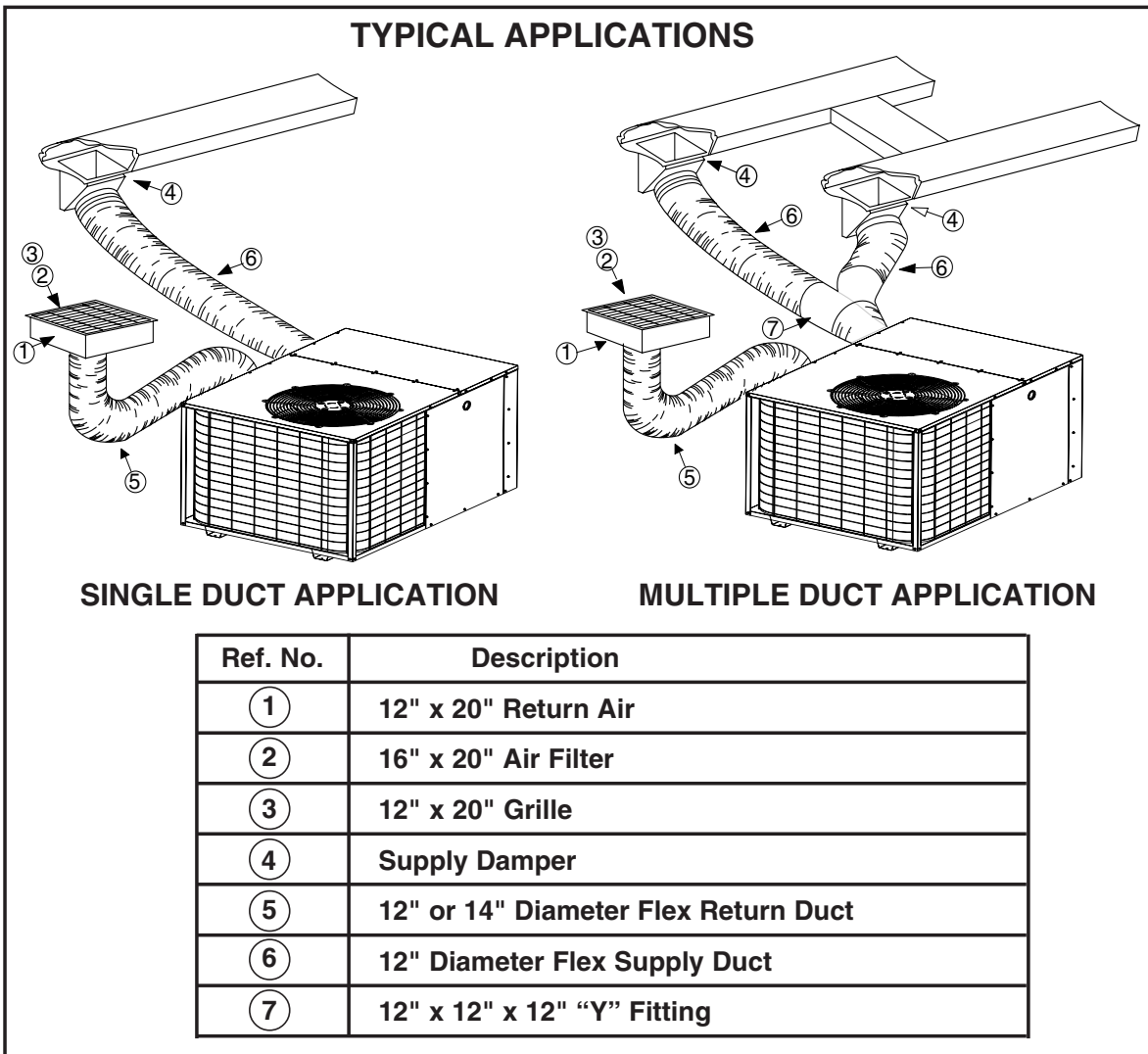

**Figure 6. Drain Trap**

performance and comfort, it may be necessary to change the factory set speed. To change the blower speed:

1. Disconnect all electrical power to the unit and remove the service panel.
2. See figure 8 for wire color vs. motor speed guide.

**Blower Speed** The blower speed is preset at the factory for operation at the same speed for heating and cooling. For optimum system



**Figure 7. Typical Applications**

- Place the desired blower speed lead on the "NO" terminal of the blower relay. Use another wire tie (field supplied) to bundle the remaining motor lead up and out of the way.

---

**! CAUTION:**

---

**To avoid personal injury or property damage, make certain that the motor leads cannot come into contact with any uninsulated metal components of the unit.**

---

Check all factory wiring per the unit wiring diagram and inspect the factory wiring connections to be sure none loosened during shipping or installation.

Model	Wire Color / Speed Tap	Motor Speed	Air Flow (0.3 In. WC)
Q3RD	Red / T1	Low	750
	Orange / T2	Med/Low	1,000
	T3	Medium	1,140
	T4	Med/High	1,300
	T5	High	1,350
2 Ton	Red	Low	760
	Black	High	1000
2.5 Ton	T1	Low	750
	T2	Med/Low	1,000
	Red / T3	Medium	1,140
	T4	Med/High	1,300
	Orange / T5	High	1,350
3 Ton	Red / T1	Low	1,340
	Orange / T2	Med/Low	1,450
	T3	Medium	1,650
	T4	Med/High	1,750
	T5	High	1,965
3.5 Ton	T1	Low	1,340
	Red / T2	Med/Low	1,450
	T3	Medium	1,650
	Orange / T4	Med/High	1,750
	T5	High	1,965
4 Ton	T1	Low	1,340
	Red / T2	Med/Low	1,450
	T3	Medium	1,650
	Orange / T4	Med/High	1,750
	T5	High	1,965

**Figure 8. Motor Lead Connection**

## CONDENSATE DRAIN

A 3/4" condensate fitting extends out of the side of the unit. The drain trap, shipped in the electrical compartment, must be installed to prevent water from collecting inside the unit. Thread the elbow provided with the unit into the drain connection until hand tight. Install the trap into the fitting making sure it is level. Route the condensate from the trap to a suitable drain. Any tubing or hose connected must have the outlet below trap level for proper drainage.

---

**! WARNING:**

---

**Turn off electrical power before servicing controls. Severe electrical shock may result unless power is turned off. Unit must be installed in compliance with the National Electrical Code (NEC) and local codes.**

---

## ELECTRICAL CONNECTIONS

### 1. ELECTRICAL SERVICE

#### High Voltage

- Install a branch circuit disconnect of adequate size per NEC. Locate the disconnect within sight of the unit.
- Extend leads through power wiring hole provided. Connect L1 and L2 directly to the contactor. (See Figure 9.)
- Ground the heat pump unit using the green grounding screw provided in the control panel.

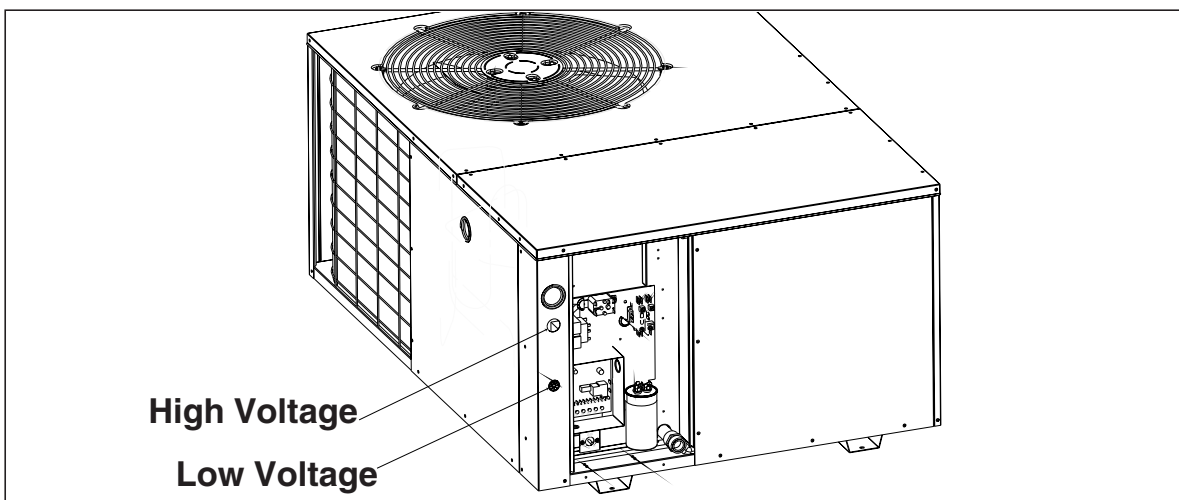

**Figure 9. Power Entry**

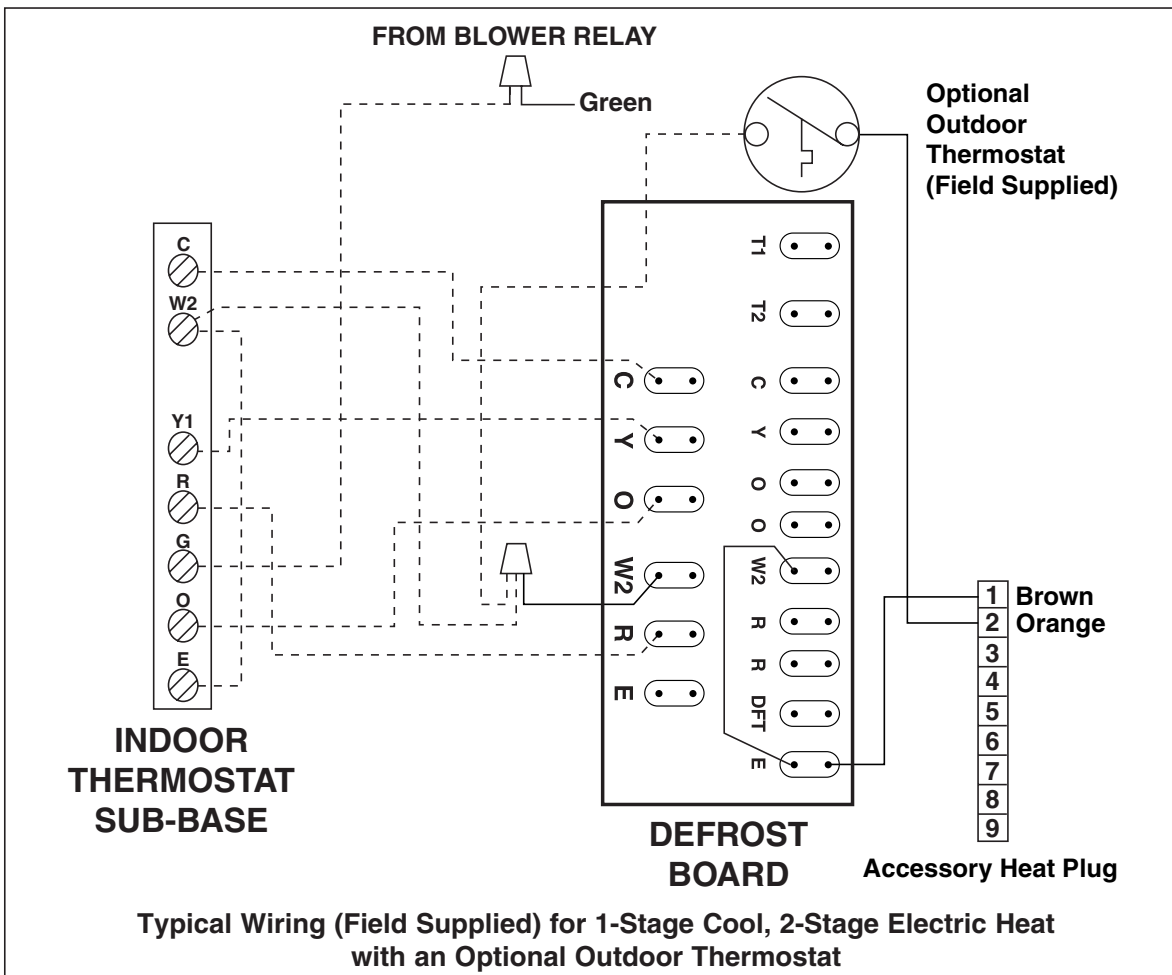
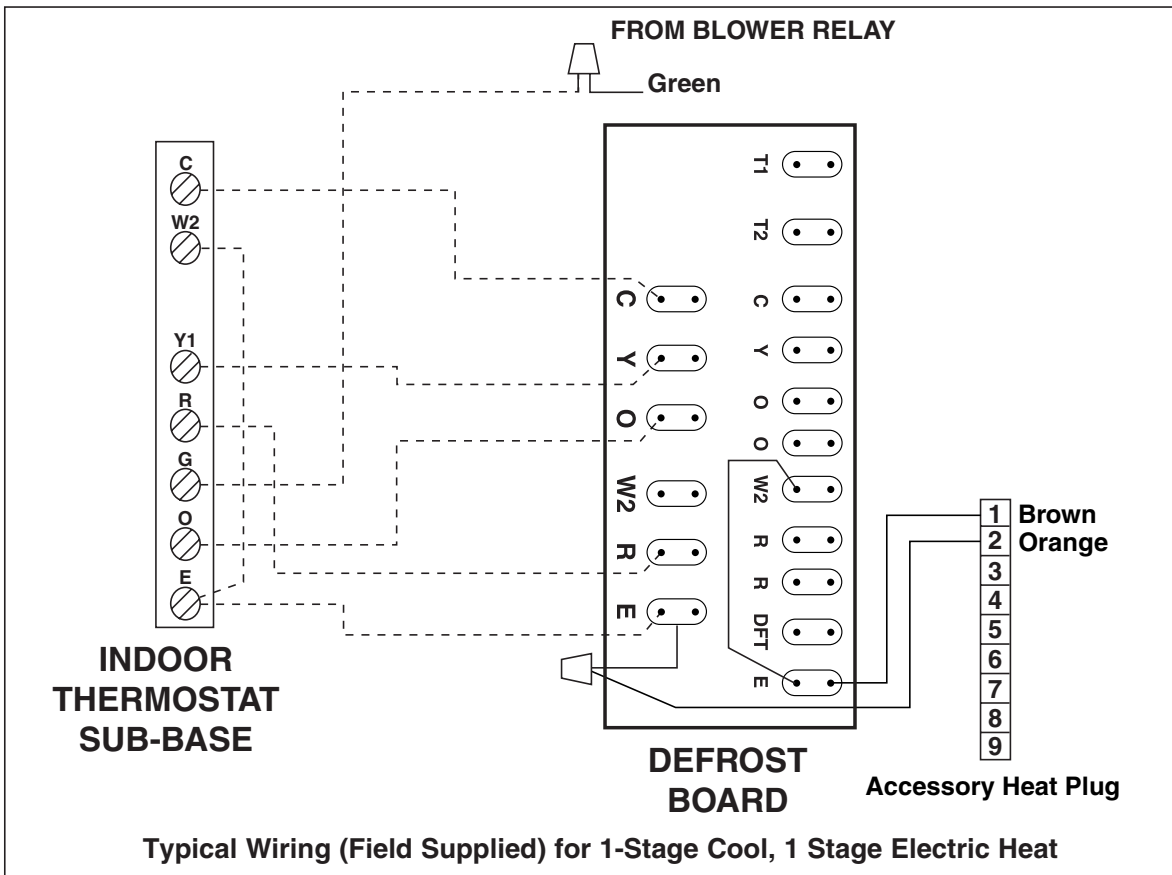

**Figure 10. Typical Heat Pump Thermostat Connections**

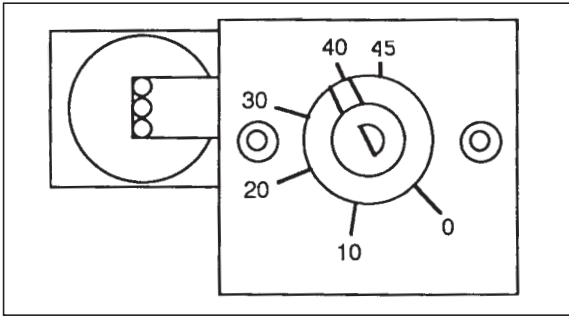

**Figure 11. Outdoor Thermostat**

### Low Voltage

- a. Route 24v control wires through the sealing grommet near the power entrance. (See Figure 9.)
- b. Connect the control wires to the defrost board and blower relay wire. (See Figure 10.)

## 2. OVERCURRENT PROTECTION

In general, the best fuse or breaker for any heat pump is the smallest size that will permit the equipment to run under normal use and service without nuisance trips. Such a device, sized properly, gives maximum equipment protection. The principal reason for specifying a time delay type is to prevent nuisance trips when the unit starts.

In the event that a fuse does blow or a breaker trips, always determine the reason. Do not arbitrarily put in a larger fuse or breaker and do not, in any case, exceed the maximum size listed on the data label of the unit.

## 3. LOCATING THE THERMOSTAT

Locate the thermostat away from drafts and slamming doors and place it where there is a free flow of air. Mount on an inside wall approximately five feet from the floor.

Do not locate near a lamp, kitchen range, direct sunlight, or in line with air flow from supply registers.

**Connect the Heat-Cool Thermostat:** The heat-cool thermostat is equipped with a system HEAT-COOL switch, which provides a positive means of preventing simultaneous operation of the heating and cooling units. The thermostat is also equipped

with an ON-AUTO fan switch which allows the home owner to operate the indoor blower when air circulation is desired.

Connect the low voltage wires to the respective terminals on the thermostat base. See thermostat instruction sheet for more detailed information. (See Figure 10).

### **If two stage heating is desired, an optional outdoor thermostat may be installed:**

Connect the thermostat to the orange low voltage wire and the W terminal on the indoor thermostat base (See Figure 10). See the thermostat instructions for details on setting the outdoor thermostat.

## 4. DEFROST CYCLE CONTROL

The defrost cycle is initiated via a signal from the defrost sensor on the outdoor coil to the defrost control board inside the control panel indicating the coil temperature is low enough to start accumulating frost. The board has interval settings of 30 minutes, 60 minutes, and 90 minutes. These time intervals represent the time elapsed before defrosting cycle starts and they are dependent on the climate conditions of the installation. A 30 minute setting would be recommended in a moist climate such as Seattle, Washington. A 90 minute setting would be adequate in a dry climate such as southern Arizona. The factory time interval setting is 30 minutes.

## 5. OUTDOOR THERMOSTAT

The outdoor thermostat prevents the electrical auxiliary heat (if used) from operating above a desired set point. Selection of the set point is determined from the building design heat load.

The thermostat is adjustable from 45°F to 0°F. The factory temperature setting is at 40°F.

## 6. ELECTRIC HEAT PACKAGE (OPTIONAL)

The heat pumps are shipped without an auxiliary electric heat kit installed. If electric heat is desired, an accessory Heater Kit must be field installed. See Specifications Sheet for available kits and their application.

- Select the correct size heat package for the installation.
- Follow installation instructions provided with each heater kit.
- Installation is most easily accomplished before making duct or electrical connections.
- Blower speed must be set to high speed for electric heat operation.

## SYSTEM OPERATION

### 1. PRE-START CHECK LIST

The following check list should be observed prior to starting the unit.

- Is the unit level? It should be level or slightly slanted toward the drain for proper condensate drainage.
- Is the unit installed with the proper clearances (See Figure 2)?
- Is the wiring correct according to the wiring diagram and electrical codes?
- Are all the wiring connections tight? Check the condenser fan to make sure it turns freely.
- Is the overcurrent protection properly sized?
- Is the thermostat wired correctly? Is it installed in a proper location?

### 2. START-UP PROCEDURE

The control circuit consists of an anti-short cycle timer that will not let compressor re-start before five (5) minutes have elapsed.

Set the thermostat system switch to OFF, and the thermostat fan switch to AUTO. Apply power at the disconnect switch and check the system operations:

- a. Air Circulation** — Leave the thermostat system switch at OFF, and set the thermostat fan switch to ON. Blower should run continuously. Check the air delivery at the supply registers and adjust register openings

for balanced air distribution. Examine ductwork for leaks or obstruction if insufficient air is detected.

Set the thermostat fan switch to AUTO; the blower should stop running.

- b. System Heating** — Set the thermostat system switch to HEAT and set the thermostat fan switch to AUTO. Position the thermostat temperature selector above the existing room temperature and check for the discharge of warm air at the supply registers.

- c. System Cooling** — Set the thermostat system switch to COOL and set the thermostat fan switch to AUTO. Position the thermostat temperature selector below the existing room temperature. Allow the cooling system to operate for several minutes and check for the discharge of cool air at the supply registers.

- d. Short cycle protection** — The control circuit is equipped with a time-delay feature for protection against short cycling. With the system operating in the cooling mode, gradually raise the thermostat temperature setting until the whole system de-energizes. Immediately lower the thermostat temperature to the original setting and verify that the indoor blower is energized. After approximately 5 minutes the compressor and the outdoor fan will energize.

- e. Emergency Heat** — (Available only when Electric heat is supplied) Set the thermostat system switch to EM HT and set the thermostat fan switch to either AUTO (intermittent air) or to ON (continuous air). Position the thermostat temperature selector above the existing room temperature and check the following:

1. The thermostat auxiliary heat light (RED) should be on.
2. The heat pump compressor and the fan should not run; low voltage circuit remains energized.
3. The blower will run according to the thermostat fan switch setting.

# 13 SEER - Refrigerant Charging Tables for Cooling Mode of Operation

2 TON	OUTDOOR TEMPERATURE (°F)															
	70		75		80		85		90		95		100		105	
Suct. Press.	Dis. Press.	Dis. Temp.	Dis. Press.	Dis. Temp.	Dis. Press.	Dis. Temp.	Dis. Press.	Dis. Temp.	Dis. Press.	Dis. Temp.	Dis. Press.	Dis. Temp.	Dis. Press.	Dis. Temp.	Dis. Press.	Dis. Temp.
72	150	121														
74	152	127	166	128												
76	154	132	168	133	182	134										
78	157	136	170	138	184	138	197	140								
80	161	139	173	141	186	143	199	144	213	145						
82			177	144	189	147	202	149	215	150	229	151				
84					192	150	205	153	217	154	231	156	245	157		
86							208	156	221	158	233	160	247	161	260	163
88							212	160	224	162	236	164	249	165	262	167
90									228	166	240	168	252	169	264	171
92											243	172	256	174	268	175
94													259	178	271	180
96															275	184
98																

2-1/2 TON	OUTDOOR TEMPERATURE (°F)															
	70		75		80		85		90		95		100		105	
Suct. Press.	Dis. Press.	Dis. Temp.	Dis. Press.	Dis. Temp.	Dis. Press.	Dis. Temp.	Dis. Press.	Dis. Temp.	Dis. Press.	Dis. Temp.	Dis. Press.	Dis. Temp.	Dis. Press.	Dis. Temp.	Dis. Press.	Dis. Temp.
75	147	122														
77	149	127	163	128												
79	152	132	165	133	179	135										
81	154	137	168	138	181	139	195	141								
83	158	139	170	142	183	144	197	145	211	147						
85			174	145	186	148	199	150	213	151	227	153				
87					190	152	202	154	215	156	229	157	243	159		
89							206	158	218	160	231	162	245	163	259	165
91							209	161	222	164	235	166	247	167	261	169
93									225	168	238	170	251	172	263	173
95											241	174	254	176	267	178
97													257	180	270	182
99															273	186
101																

### Refrigerant Charging Chart Legend for Cooling Mode of Operation

\* Note: All pressures are listed in psig. and all temperatures in °F.



- Shaded Boxes indicate flooded conditions



- Rated Design Values. Suction Pressure will be lower than design value if indoor air flow, entering dry bulb, or entering wet bulb temperatures are lower than design.

- Discharge temperatures greater than charted values indicate an undercharged system.

## 13 SEER - Refrigerant Charging Tables for Cooling Mode of Operation Continued

3 TON	70		75		80		85		90		95		100		105		
	Suct. Press.	Dis. Press.	Dis. Temp.	Dis. Press.	Dis. Temp.	Dis. Press.	Dis. Temp.	Dis. Press.	Dis. Temp.	Dis. Press.	Dis. Temp.	Dis. Press.	Dis. Temp.	Dis. Press.	Dis. Temp.	Dis. Press.	Dis. Temp.
72	156	121															
74	158	126	172	128													
76	160	131	174	133	188	134											
78	163	136	176	138	190	139	204	141									
80	167	138	179	142	192	144	206	146	220	148							
82			183	145	195	148	208	150	222	152	236	154					
84					199	151	211	154	224	157	238	159	252	161			
86							215	158	227	160	240	163	254	165	268	167	
88							218	161	231	164	243	167	256	169	270	171	
90									234	168	247	171	259	173	271	175	
92											250	175	263	177	275	180	
94													266	182	279	184	
96															282	188	
98																	

3-1/2 TON	70		75		80		85		90		95		100		105		
	Suct. Press.	Dis. Press.	Dis. Temp.	Dis. Press.	Dis. Temp.	Dis. Press.	Dis. Temp.	Dis. Press.	Dis. Temp.	Dis. Press.	Dis. Temp.	Dis. Press.	Dis. Temp.	Dis. Press.	Dis. Temp.	Dis. Press.	Dis. Temp.
69	156	127															
71	158	133	171	135													
73	160	138	173	140	187	142											
75	163	141	176	145	189	147	202	150									
77	167	144	179	148	191	152	204	154	218	157							
79			182	151	194	156	207	159	220	162	234	165					
81					198	159	210	163	222	166	236	169	249	172			
83							213	166	225	170	238	173	251	176	265	179	
85							217	170	229	174	241	177	253	180	267	183	
87									232	178	244	181	257	184	269	187	
89											248	185	260	189	272	192	
91													263	193	276	196	
93															279	200	
95																	

### Refrigerant Charging Chart Legend for Cooling Mode of Operation

\* Note: All pressures are listed in psig. and all temperatures in °F.



- Shaded Boxes indicate flooded conditions



- Rated Design Values. Suction Pressure will be lower than design value if indoor air flow, entering dry bulb, or entering wet bulb temperatures are lower than design.

- Discharge temperatures greater than charted values indicate an undercharged system.

## 13 SEER - Refrigerant Charging Tables for Cooling Mode of Operation Continued

4 TON	70		75		80		85		90		95		100		105		
	Suct. Press.	Dis. Press.	Dis. Temp.	Dis. Press.	Dis. Temp.	Dis. Press.	Dis. Temp.	Dis. Press.	Dis. Temp.	Dis. Press.	Dis. Temp.	Dis. Press.	Dis. Temp.	Dis. Press.	Dis. Temp.	Dis. Press.	Dis. Temp.
67	157	131															
69	159	136	174	139													
71	161	142	176	144	191	147											
73	162	150	178	149	193	151	209	154									
75	166	152	180	155	196	156	211	159	226	161							
77			183	158	197	161	213	163	228	166	243	169					
79					201	165	215	168	230	170	245	173	260	175			
81							219	171	233	174	247	177	262	179	277	182	
83							222	175	236	178	251	181	264	183	279	186	
85									240	182	254	185	268	188	281	190	
87											257	189	272	192	286	195	
89													275	196	289	199	
91															293	204	
93																	

### Refrigerant Charging Chart Legend for Cooling Mode of Operation

\* Note: All pressures are listed in psig. and all temperatures in °F.



- Shaded Boxes indicate flooded conditions



- Rated Design Values. Suction Pressure will be lower than design value if indoor air flow, entering dry bulb, or entering wet bulb temperatures are lower than design.

- Discharge temperatures greater than charted values indicate an undercharged system.

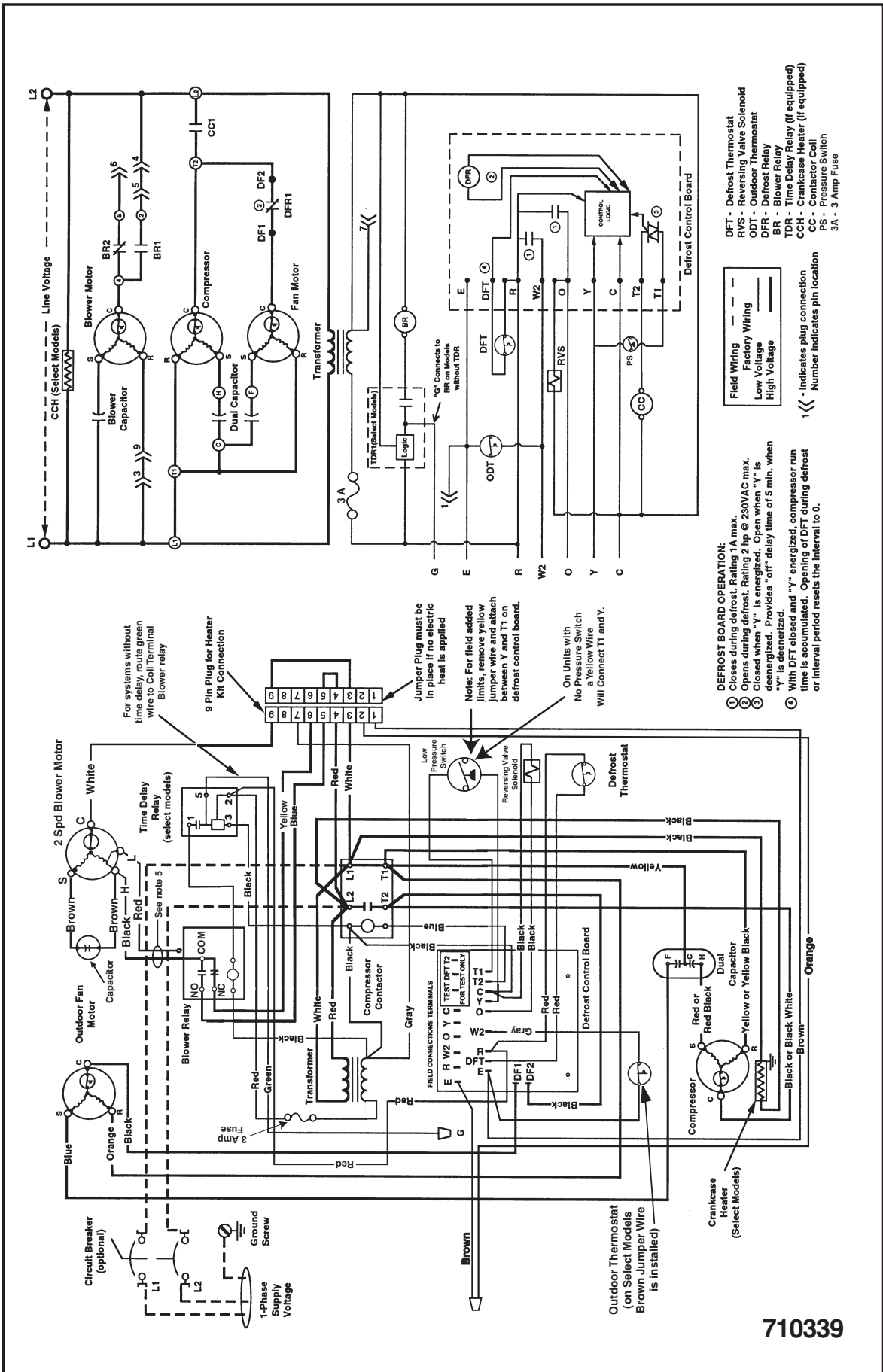

710339

## Small Packaged Heat Pump - Single Phase

- NOTES:
1. Disconnect all power before servicing.
  2. For supply connections use copper conductors only.
  3. Not suitable on systems that exceed 150 V to ground.
  4. For replacement wires use conductors suitable for 105° C.
  5. On models who pressure switch 15-YE(28) connects "Y" & "T1" on Defrost Board.

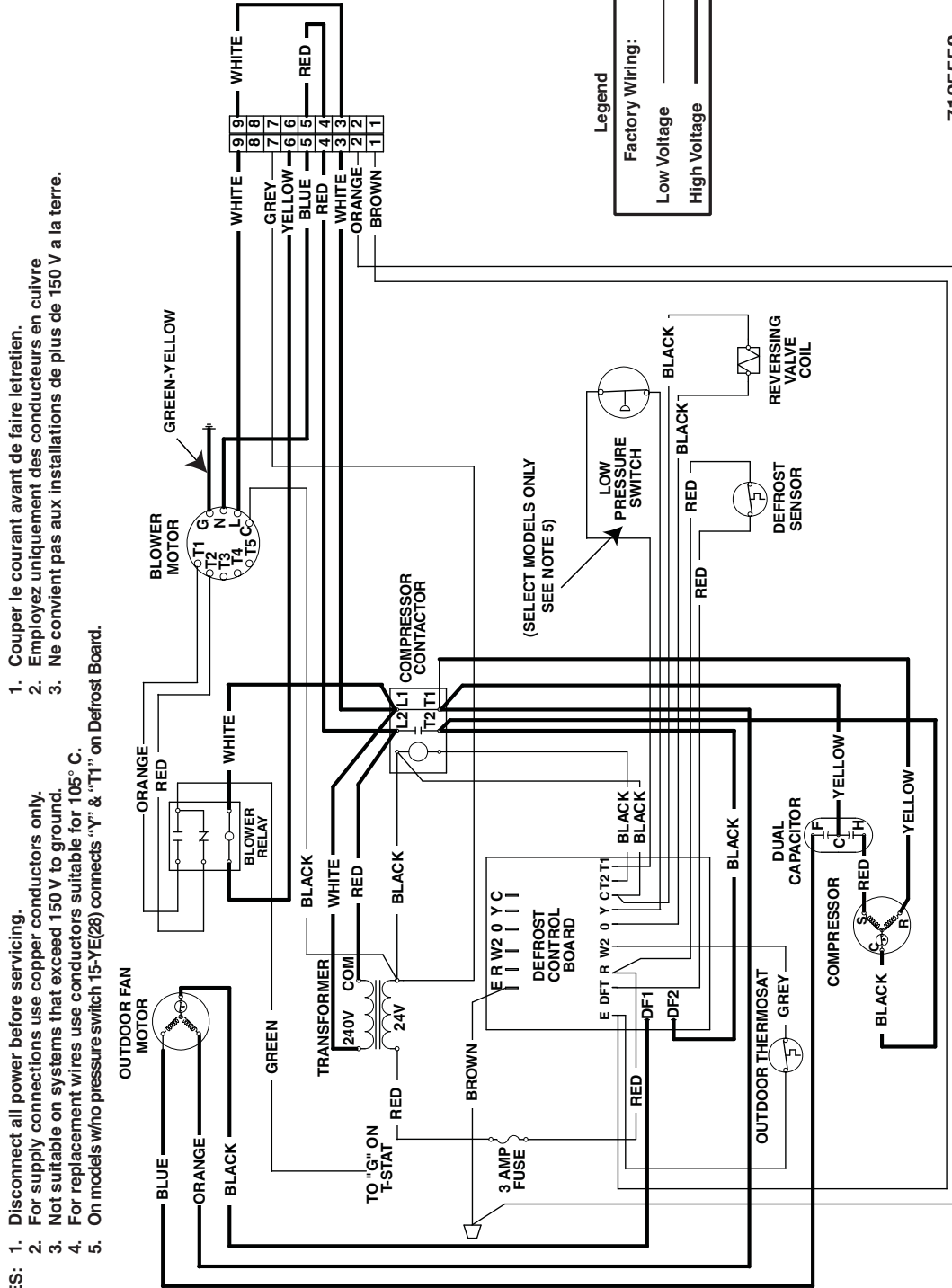

Legend

Factory Wiring:	_____
Low Voltage	_____
High Voltage	_____

7105550

## Small Packaged Heat Pump - Single Phase

- NOTES:
1. Disconnect all power before servicing.
  2. For supply connections use copper conductors only.
  3. Not suitable on systems that exceed 150 V to ground.
  4. For replacement wires use conductors suitable for 105° C.
  5. On models w/no pressure switch 15-YE(28) connects "y" & "T1" on Defrost Board.
1. Couper le courant avant de faire l'entretien.  
 2. Employez uniquement des conducteurs en cuivre  
 3. Ne convient pas aux installations de plus de 150 V a la terre.

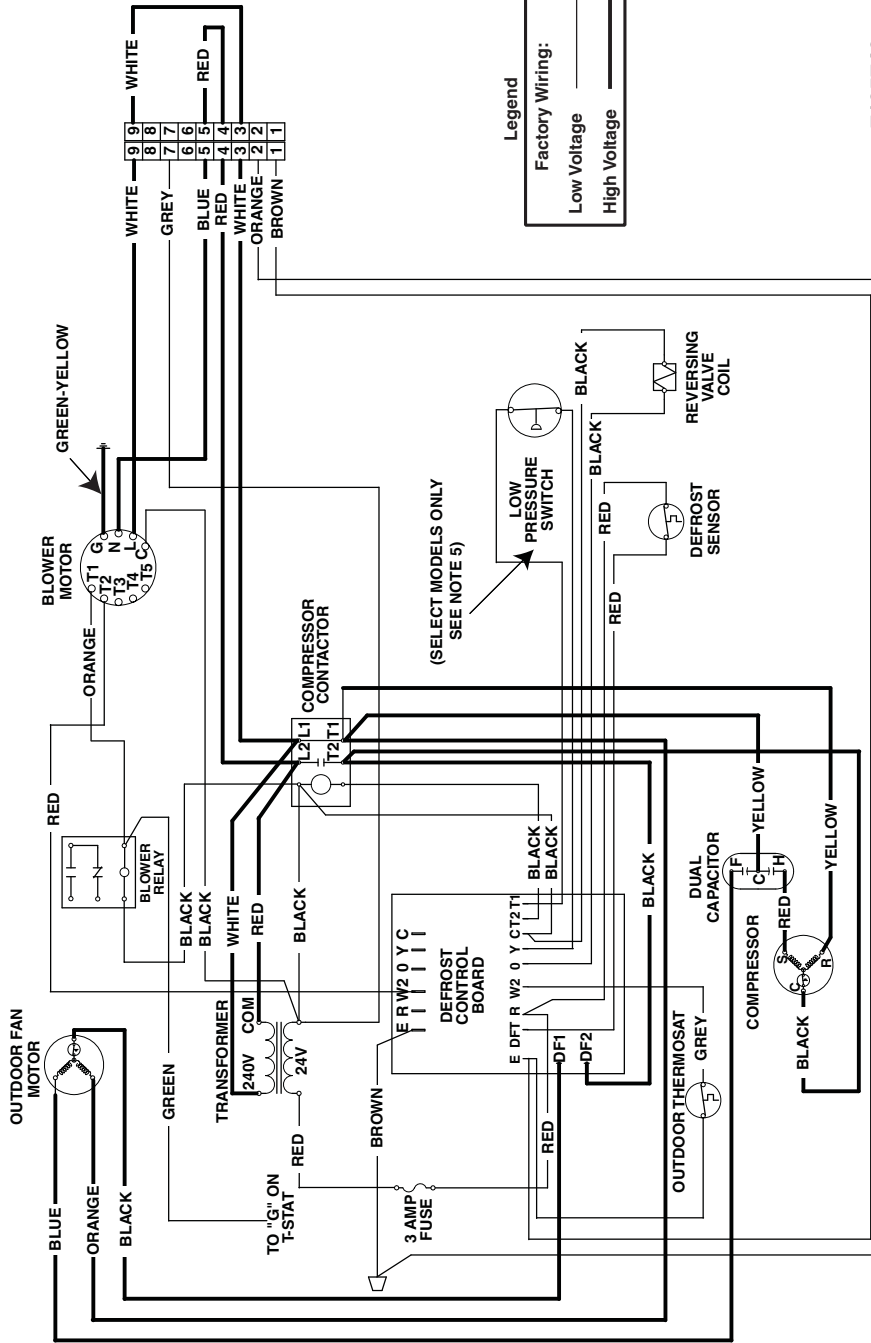

Legend  
 Factory Wiring: \_\_\_\_\_  
 Low Voltage \_\_\_\_\_  
 High Voltage \_\_\_\_\_

7105740

**INSTALLER**  
**PLEASE LEAVE THESE INSTALLATION INSTRUCTIONS WITH THE HOMEOWNER.**



7084450

7084450 (Revised 1/26/06)

Specifications and illustrations subject to change without notice and without incurring obligations. (01/06)