

Installation Instructions

B5BV Series Electric Furnaces

For HUD approved installations in manufactured homes and modular homes

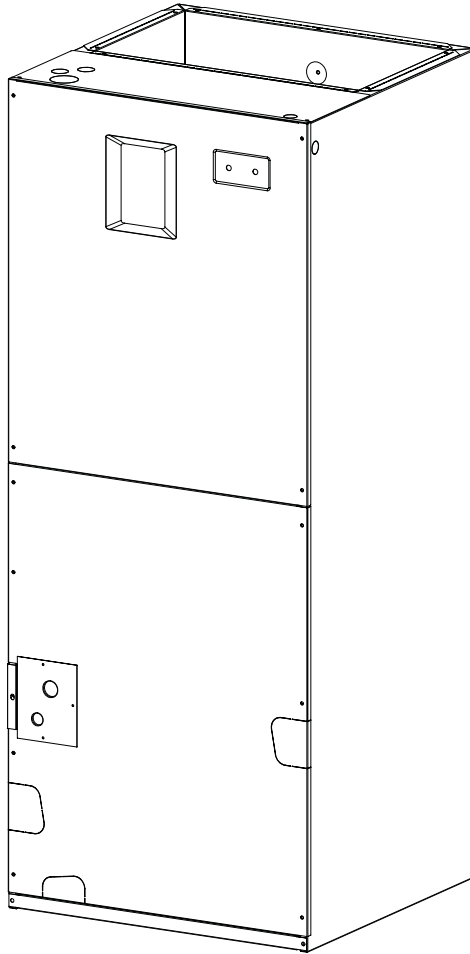

These instructions are intended to assist qualified individuals experienced in the proper installation of heating and/or air conditioning appliances. Some local codes require licensed installation/service personnel for this type equipment. All installations must be in accordance with these instructions and with all applicable national and local codes and standards. Improper installation, service, adjustment, or maintenance can cause, fire, electrical shock or other conditions which may result in personal injury or property damage. Unless otherwise noted in the instructions, only factory authorized kits or accessories may be used when modifying this product.

INTRODUCTION

The B5BV Series electric furnaces are approved for use in HUD code manufactured homes (HUD Manufactured Home Construction and Safety Standard (Title 24, Part 3280)) and other modular home applications.

The B5BV Series electric furnace may be installed in downflow or upflow applications as “freestanding” units, and in closet or alcove installations.

B5BV Series electric furnaces are supplied with factory installed electric heat. Approved NORDYNE heat-pump/air conditioning coils may be installed in the field.

GENERAL INFORMATION

Codes

All electrical power wiring for the B5 series electric furnace must be installed in accordance with:

- 1) HUD Manufactured Home Construction and Safety Standard
- 2) NFPA 70 - National Electric Code (NEC)

NOTE : Circuit breakers installed in the B5 electric furnace are for short-circuit protection of the internal wiring and to serve as a unit disconnect. Circuit breakers installed in the B5BV electric furnace **DO NOT** provide over-current protection of the supply wiring. Over-current protection of the supply wiring must be provided at the distribution panel and sized as shown in the installation instructions or on the unit data label, and per the NEC.

Location

Reference the installation instruction included with this unit for location requirements.

Clearance

All electric heater kits less than 20 kw are approved for use in air handler installations with zero-clearance to combustibles at any blower speed. For horizontal and upflow configuration, B5 electric furnace equipped with 20 kw electric heater kits are approved for installation with zero clearance to combustibles at any blower speed. When using a 20 kw electric heat kit in a downflow installation, the blower must be set for high speed for both heating and cooling.

VENTILATION

The B5BV electric furnace has a cut-out on each side for ventilation air. Use NORDYNE part number 914120 or

914427 adaptor with VentilAire III or IV to supply the proper amount of ventilation air. The VentilAire connections must be made for the system to conform to H.U.D. rules. Do not leave disconnected after servicing or adding A/C to the system.

RETURN AIR

In closet or alcove installations provide at least 235 square inches free opening for return air for B-cabinet (19 3/4" wide) models and 300 square inches for C-cabinet (22 1/2" wide) models.

The return air opening can be located in a closet door or a sidewall. If the return air opening is directly adjacent to the side (or front) of the air handler, 6" minimum clearance must be provided between the side of the furnace and the return air opening. If no part of the return air opening is directly adjacent to the unit no clearance is required.

If an upflow pedestal mounting stand is fabricated in the field it must be constructed strong enough to support the unit with all accessories installed (approximately 130 lbs. for B-cabinet models and 200 lbs. for C-cabinet models). The construction of the pedestal stand must also allow for at least 235 square inches free opening (300 square inches for C-cabinet models) in the application. Field fabricated upflow pedestal mounting stands must be constructed of noncombustible materials.

Refer to the installation instruction included with this unit for other return air details.

SUPPLY AIR DUCTS

The duct system must be designed so that the external static pressure of the system does not exceed the maximum external static pressure indicated on the unit data label.

Description	Cabinet Size	
	B	C
Downflow Plenum Connector, 6.25"	913840	914969
Downflow Plenum Connector, 8.25"	913841	914970
Downflow Plenum Connector, 10.25"	913842	914971
Upflow Pedestal Mounting Stand	913872	913873
Downflow Coil Adaptor	919321	919322 *919323

* Use when installing B width coil in C width cabinet

Table 1. Optional Accessory Kits

Downflow applications require the use of a plenum connector shown in Figure 1 or its equivalent if the supply air ducts pass through the floor of the structure. See Table 1 for plenum connectors available.

The plenum connectors are designed for use with trunk ducts having a minimum width of 12 in. If sufficient space is not available to adequately bend and secure plenum tabs it may be necessary to attach the connector to the duct using sheet-metal fasteners and seal with an approved foil tape.

Plenum connectors may be field constructed but must meet requirements as stated in the unit installation instructions.

INSTALLATION

Install the unit as directed in the Installation Instructions. NOTE: The perforated flange located at the unit's supply air outlet should be folded upward 90° on all four sides before the unit is set into position as shown in Figure 1a. NOTE: Secure the unit to the structure using metal strap and/or fasteners at the top of the unit and at the bottom of the unit.

POWER WIRING

WARNING:

To avoid risk of electric shock, personal injury, or death, disconnect electrical power to the unit before performing any maintenance or service. The unit may have more than one electric power supply.

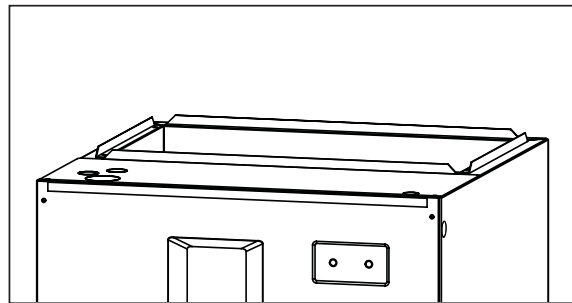

Figure 1a. Perforated Flange at Outlet

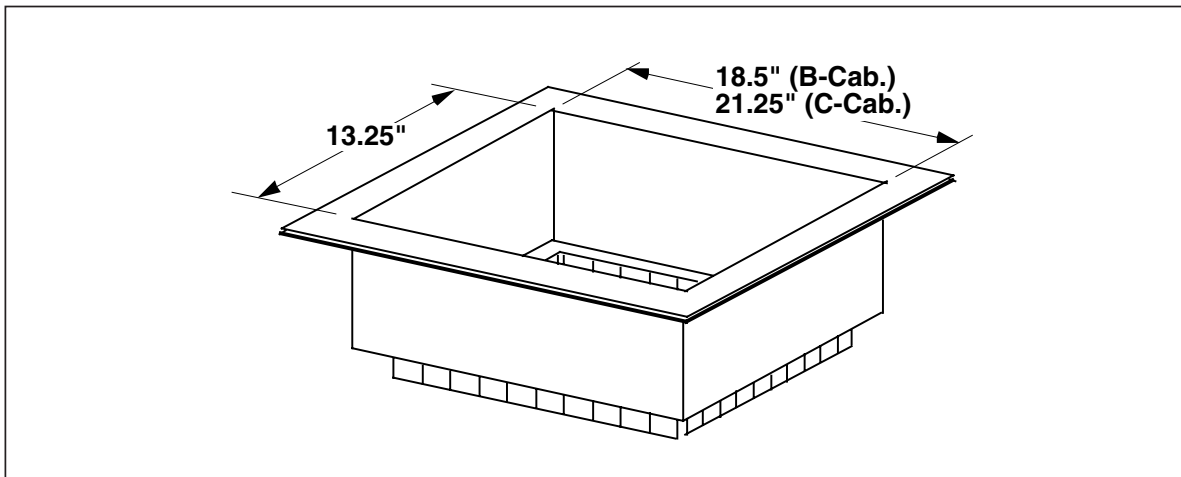

Figure 1. Plenum Adapter

			B5BV					
			Minimum Circuit Ampacity			Maximum Over-Current Protection		
Model #	Voltage	KW	Circuit A	Circuit B	Single Circuit	Circuit A	Circuit B	Single Circuit
10 KW	240	9.6	57.5	-	57.5	60.0	-	60.0
15 KW	240	14.4	53.6	25.0	78.6	60.0	30.0	90.0
20 KW	240	19.2	57.5	50.0	107.5	60.0	50.0	125.0

Table 2. Electrical Data

All wiring must comply with the current revision of the National Electric Code and must be sized for the minimum ampacities as listed on the unit data label or in Table 2.

If a single circuit adaptor kit is used, it may need to be re-configured for some applications. Remove the single circuit adaptor kit cover and verify that the lugs are configured correctly for the application. If the lugs are not configured for the application, refer to the instructions included with the kit and modify the configuration. Install the single circuit adaptor kit (if used) in the line side ("on" end) of the circuit breakers. Tighten the lugs securely (45 in-lbs recommended).

Connect the supply wiring to the circuit breakers, single circuit adaptor kit, or terminal block. Tighten the lugs securely.

When using dual supply circuits verify that the supply sized for circuit "A" is connected to the circuit breaker that is connected to the top element assembly.

Replace metal circuit breaker line cover. Refer to Figure 2 for thermostat wiring examples.

A/C or H/P COIL INSTALLATION

Approved air conditioning and heat pump system components are listed on the unit nameplate.

To install the indoor coil:

1. Remove door cover plate, door and coil close-off plate (with insulation). Discard door cover plate.
2. For upflow applications slide the coil into the track located in the bottom of the unit.
3. For downflow applications the downflow adaptor (see Table 1) must be used. Install the downflow adaptor and coil as directed in the instructions included with the kit.
4. Reinstall the door and coil close-off plate (with insulation). NOTE: In downflow applications the door is rotated 180° so that the refrigerant and condensate lines remain on the left side.
5. Install the refrigerant and condensate lines as directed in the instructions included with the outdoor unit.

MOTOR SPEED SELECTION

NOTE: The control board is programmed with a 40 second off delay in the cooling mode for optimum system performance and efficiency.

The blower speed is preset at the factory for operation at the same speed for heating and cooling, by using the blower motor jumpering terminal on the blower motor and connecting it to the desired speed with both the red and black wires connected to the jumpering terminal. For optimum system performance and comfort,

it may be necessary to change the factory set speed. To change the blower speed, disconnect all electrical power to the unit and remove the upper door. Remove the black and red wires from the blower motor jumpering terminal. Discard the blower motor jumpering terminal.

Connect the heating speed wire (red) and the cooling speed wire (black) to the desired blower speed marked on the terminal block of the blower motor. On 4-speed motors terminal 2=Hi, terminal 3=Med-HI, terminal 4=Med-Low and terminal 5=Low.

C cabinet units are equipped with 5 selectable blower speeds. Terminal 1=Low speed, terminal 2=Medium Low speed, terminal 3=Medium speed, terminal 4=Medium Hi speed, and terminal 5=Hi speed.

Replace the upper door and secure it to the unit. Restore power to the unit.

High speed operation is required with 20 kw B5 electric furnaces in downflow applications.

Selecting continuous low speed fan operation — The B5 electric furnace is equipped with the option of continuous low speed fan operation. When G is energized without Y1/2, the air handler will operate using the heating speed. With G & Y1/2 or Y1/2 energized, the B5 electric furnace will operate in the selected cooling speed (including 40 sec blower-off delay).

NOTE: To achieve continuous low speed fan operation Y must be connected at the B5 electric furnace.

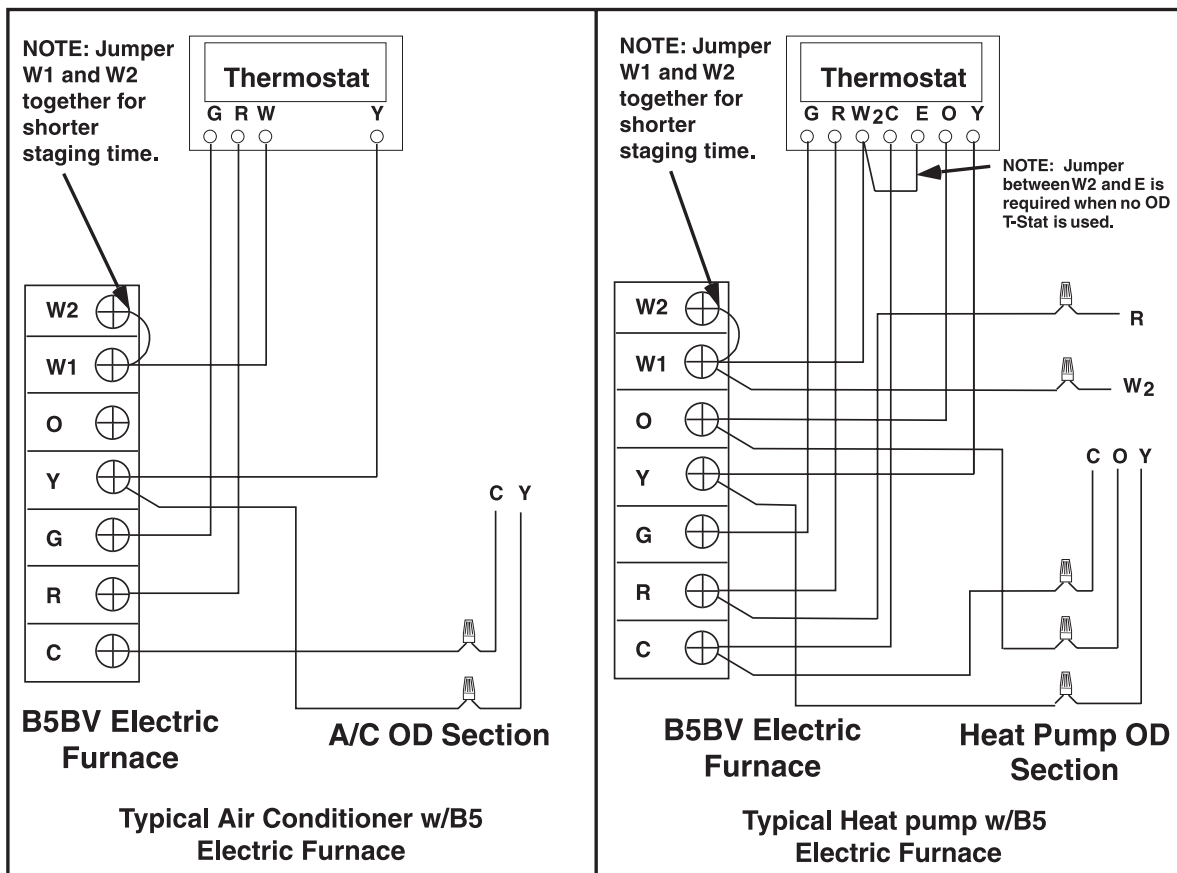
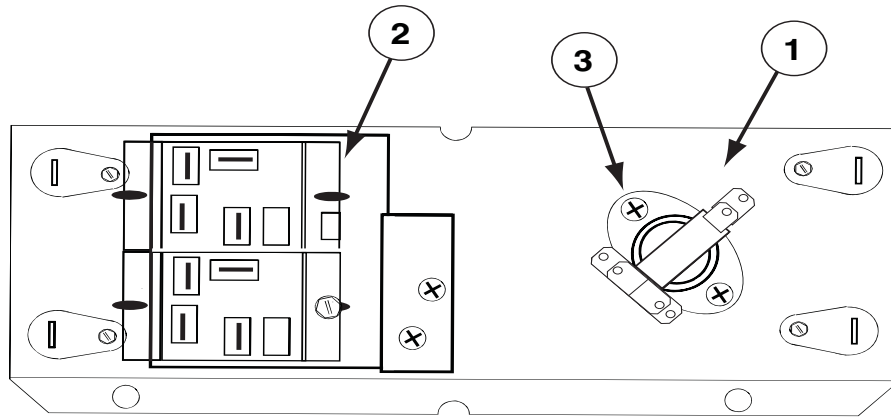

Figure 2. Typical Air Conditioning and Heat Pump System Connections on B5BV electric furnaces with Circuit Board



ITEM NO.	PART NO.	DESCRIPTION	B5BV			
			010K-B	015K-B	010K-C	020K-C
1	491214	Element Assembly - 4.8 kw		1		
	491225	Element Assembly - 9.6 kw	1	1	1	2
2	622210	Relay	2	3	2	4
3	626487	Limit, 1-pole, 190° F		1		
	626458	Limit, 2-pole, 190° F	1	1	1	2
4	632249	Circuit Breaker, 2-pole, 60 amp (not shown)	1	2	1	2

Heater Kit Replacement Parts List

**INSTALLER: PLEASE LEAVE
THESE INSTALLATION INSTRUCTIONS
WITH THE HOMEOWNER**



708494B

708494B (Replaces 708494A)