

Field Replacement Gas Gun Motor Kit, #904478

Installation Instructions

For Gas Gun Motor, M1 and CMF Series

IMPORTANT: Read these instructions and the main furnace Installation Instructions carefully before beginning the replacement.

GENERAL

These instructions are primarily intend to assist qualified individuals with service experience. This kit to be used for field replacement of combustion motor for manufactured housing furnaces. These instructions are intended to guide replacing of old motor with new motor that includes

a mounting bracket. However, these instructions do not include disassembling of existing motor from the fan assembly. Some local codes require licensed installation/ service personnel for installation of this type equipment.

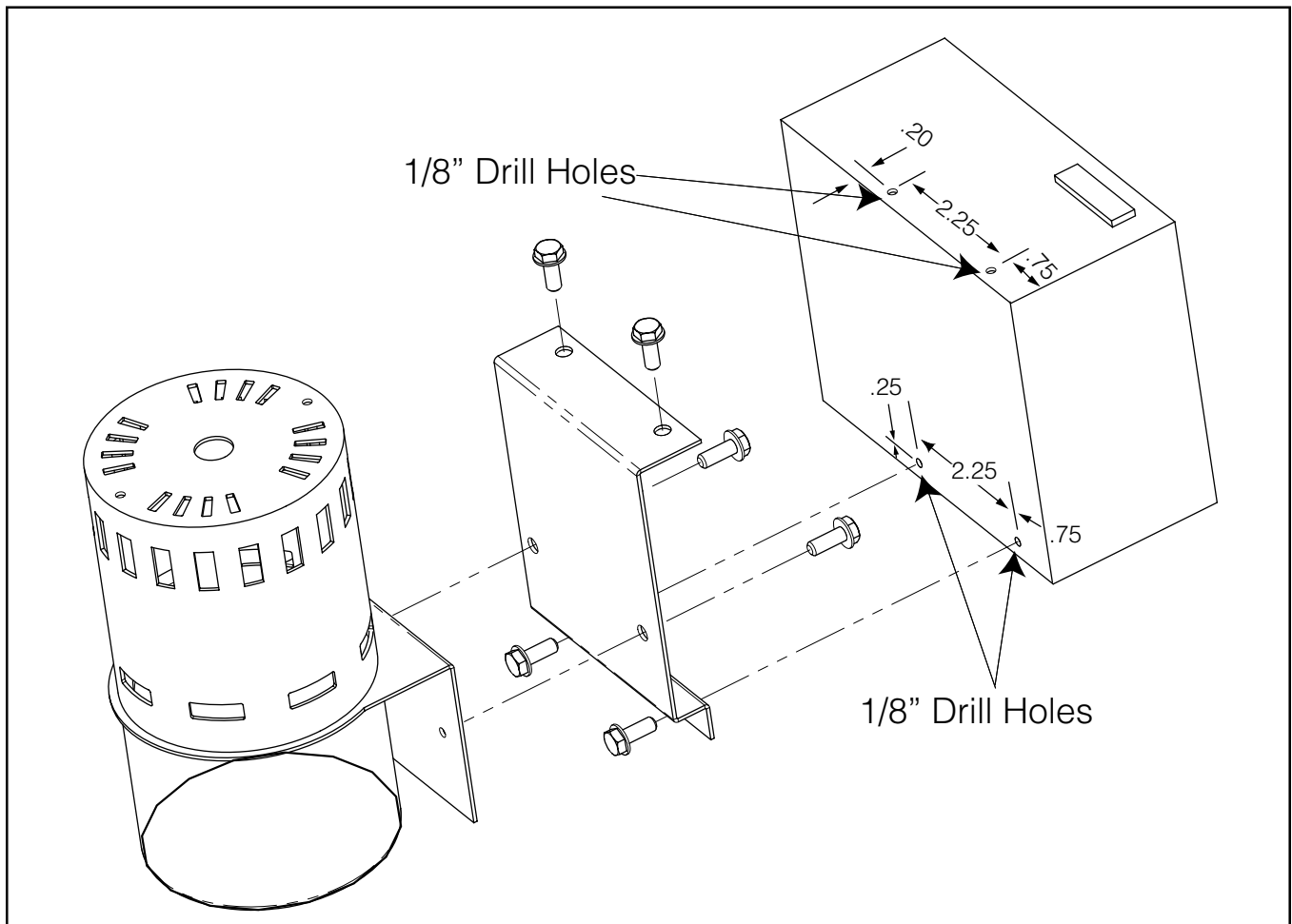

Figure: Intermediate Mounting Bracket Assembly

Contents of kits

1. Installation Instructions, #708510
2. 1- Motor, #622065
3. 1-Motor Bracket, #289141
4. 6-Screws

WARNING:

The replacement motor must be installed by a qualified service technician in accordance with these instructions and all codes having jurisdiction. Failure to follow these instructions could result in serious injury, property damage, or death. The qualified service technician performing this work assumes responsibility for this replacement.

DISASSEMBLING THE BURNER

- A. Turn off gas shut-off valve and electric power outside furnace.
- B. Turn down thermo stat below room temperature.
- C. Unplug burner cord from furnace
- D. Disconnect thermo stat wires if applicable
- E. Disconnect gas line.
- F. Remove three burner mounting nuts.
- G. Carefully remove burner from furnace.

INSTALLING THE KIT

- A. Remove old motor from the fan motor assembly
- B. Remove motor from junction box by removing mounting strap.
- C. Install new motor to the fan assembly
- D. Assemble supplied bracket on the motor bracket with two screws.

- E. Remove the strap from the junction box bottom by using tin snips. Make sure any remaining strap lies flat on junction box.
- F. Mark hole locations to dimensions shown in Figure.
- G. Drill the holes by using 1/8" bit.
- H. Assemble junction box with the bracket that installed on the motor bracket with four screws. (See Figure). Note: Ensure if wires inside boxes are not damage while drilling and screwing.
- I. Reassemble all the items that were removed with reverse action

CHECKING BURNER

- A. Check gas line using an approved leak test method. Note: Do not use flame
- B. Run furnace per the main installation instructions at least three times for 5 minutes before leaving the home.

