

## DT3BC Series Extra High Efficiency Heat Pumps 12 SEER Residential System 1-1/2 – 5 Ton Capacity

The DT3BC Series of heat pumps offers exceptional performance from a small, compact package. The heat pump, when combined with our engineered coils or air handlers, offers a full line of quality, split system heating and cooling equipment. Units are ideally sized for slab or rooftop mounting in single, multifamily, and light commercial applications.

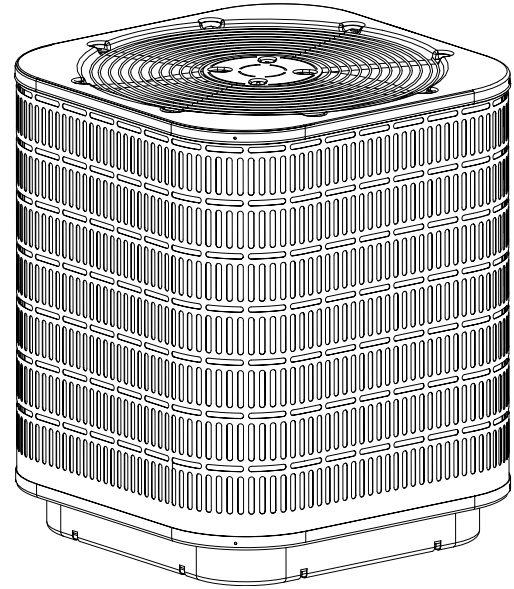

### FEATURES and BENEFITS

- **Designed using galvanized steel** – with a polyester urethane coat finish. The 950 hour salt spray finish resists corrosion 50% better than comparable units.
- **Copper Tube / Aluminum Fin Coils** – Both indoor and outdoor coils are designed to optimize heat transfer, minimize size and cost, and increase durability and reliability.
- **Permanently Lubricated Motor** – A heavy duty PSC motor for long lasting reliability and quiet operation. Requires no maintenance and is completely protected from rain and snow.
- **Full Service Valves** – These brass valves are easily accessible and simplify servicing of the refrigeration system.
- **Steel Guard™** – Protects the unit coil from being damaged by balls, lawnmowers, hail, etc.
- **Time/Temperature Defrost** – A reliable, industry standard control offers various time settings to meet any type climate.
- **Removable Top Grille Assembly** – Allows ease of service from the top without disconnecting fan motor leads.
- **Hail Guard** – Plastic mesh protects coil from hail damage.
- **One Piece Top/Orifice** – Designed for maximum airflow and quiet operation.
- **Common Suction Service Port** – This port allows the contractor to read the suction pressure in all modes of operation without removing any panels, saving time and increasing serviceability.
- **2-1/2" Pedestal Base** – The sturdy base keeps the bottom of the coil out of harms way. Secondly, the base has weep holes along the edge to allow the water from the defrosting coil and rain to flow away from the unit.
- **Five Minute Restart Time Delay** – When the unit shuts down, a five minute delay keeps the unit from restarting, eliminating the highest cause for compressor failure.
- **Suction Accumulator** – Protection from liquid flood back and future compressor failures. All 12 seer H.P. have scroll compressors.
- **Hot Gas Muffler** – Reduces compressor noise and vibration.
- **Easy Compressor and Control Access** – Designed to make servicing easier for the contractor, access panels are provided to all controls and the compressor from the side of the unit.
- **Warranty** – The best in the industry.
  - 5 year limited parts
  - 2 year mileage
  - 2 year labor

## MODEL IDENTIFICATION CODES

EX: DT3BC-036K A

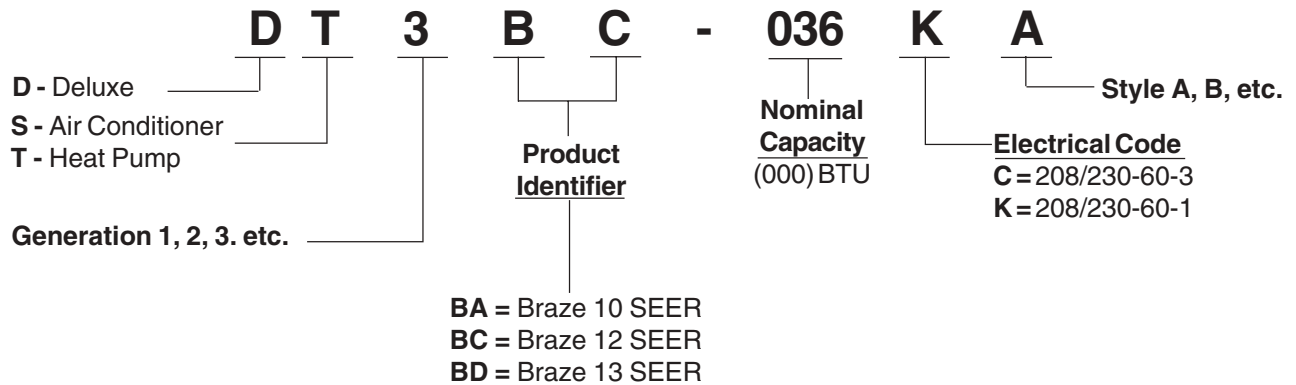

## DIMENSIONS HEAT PUMP OUTDOOR SECTION

DT3BC-	018KA	024K	030K	036K	042K	048K	060K
H	26 1/2	30 1/2	34 1/2	38 1/2	42 1/2	38 1/2	42 1/2
W	22 1/2	30 1/2	30 1/2	30 1/2	30 1/2	30 1/2	30 1/2
D	22 1/2	30 1/2	30 1/2	30 1/2	30 1/2	30 1/2	30 1/2

Air Discharge  
Allow Adequate Clearance for Airflow

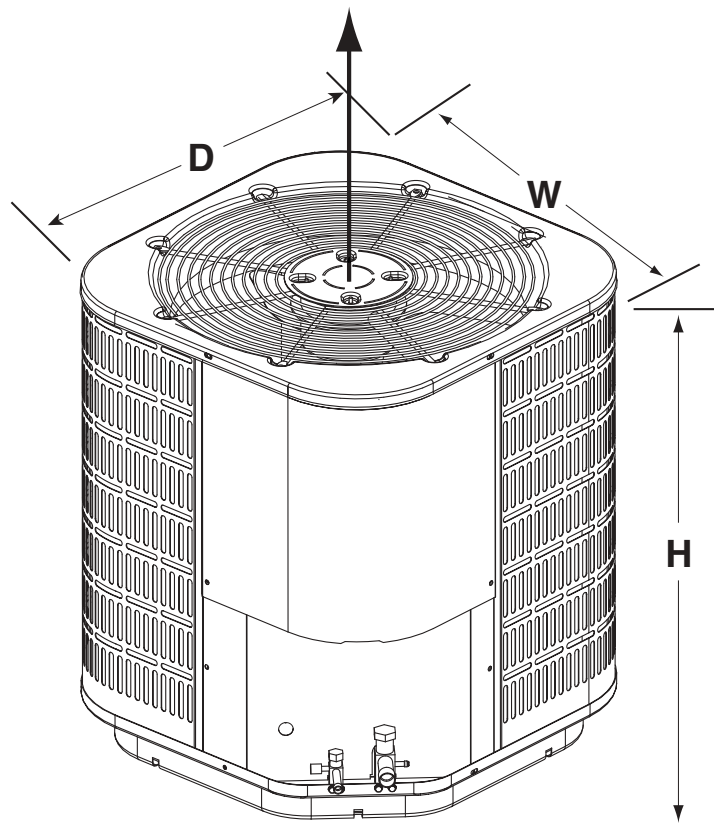

# PHYSICAL AND ELECTRICAL SPECIFICATIONS / OUTDOOR UNITS

## 12 SEER — High Efficiency — Single Phase

Model No. DT3BC-		18KA	24K	30K	36K	42K	48K	60K	
<b>Electrical</b>	Volts-Cycles-Phase (1)	208/230-60-1	208/230-60-1	208/230-60-1	208/230-60-1	208/230-60-1	208/230-60-1	208/230-60-1	
<b>Data</b>	Total Amps	10.3	11.6	13.6	17.4	19.4	20.7	30.3	
	Delay Fuse Max. (2)	20	20	25	35	40	40	60	
	Min. Circuit Ampacity	12.6	14.2	16.6	21.4	23.9	25.5	37.5	
<b>Component Data</b>	Coil	Area	9.87	17.9	20.4	23.0	25.5	23.0	25.5
		Rows-FPI	1-18	1-18	1-18	1-20	1-20	2-16	2-16
		Tube Dia.	3/8 O.D.	3/8 O.D.	3/8 O.D.	3/8 O.D.	3/8 O.D.	3/8 O.D.	3/8 O.D.
	Fan Motor	Type	PSC	PSC	PSC	PSC	PSC	PSC	PSC
		Amps	0.34	1.4	1.4	1.4	1.5	1.5	1.5
		Watts-HP	37 1/20	245	245	245	300	300	300
	Fan Blade	Dia.-#Blades	18 in. - 3	24 in. - 3	24 in. - 3	24 in. - 3	24 in. - 3	24 in. - 3	24 in. - 3
		SCFM	2000	3300	3300	3300	4000	4000	4000
	Compressor Data*	RLA	10.0	10.2	12.2	16.0	17.9	19.2	28.8
		LRA	42	56	67	88	104	137	169
<b>Refrigerant Suction Line- Length/O.D. (Liq. Line)</b>	15 - 24 ft.	5/8" (3)	5/8" (3)	3/4"	3/4"	3/4"	7/8"	7/8"	
	25 - 39 ft.	3/4"	3/4"	3/4"	3/4"	7/8" (4)	7/8"	1 1/8" (5)	
	<b>All Lengths - 3/8" O.D.)</b>	40 - 75 ft.	3/4"	3/4"	3/4"	7/8" (4)	7/8" (4)	7/8"	1 1/8" (5)
<b>Refrigerant Charge R-22 Ounces</b>	(Outdoor unit, Indoor Unit, 15' Line Set)	72	112	133	146	162	240	264	
<b>Weight Approximate (lbs.)</b>	Net	162	170	178	188	204	253	282	
	Ship	174	182	190	200	216	265	294	

\* Values shown are most severe and may vary slightly depending on the make of compressor supplied.

(1) Operating Voltage Range: 198v min. - 253v max.

(2) HACR type circuit breakers may be used.

(3) Requires 3/4" to 5/8" reducer from unit to line.

(4) Requires 7/8" to 3/4" reducer from unit to line.

(5) Requires 7/8" to 1 1/8" reducer from unit to line.

## ACCESSORIES - Condensing Unit

### Start Assist Kit - 912933

Provides additional starting torque for the compressor motor when operating with low line voltage or high operating temperatures.

### Snow Stand

Plastic-coated, molded wire stand which elevates units 7-1/4" above ground level.

913145 - (018 through 060) Shipped six (6) per box.

### Outdoor Thermostat - 913235

Two-stage logic provides ability to lock out electric strips down to balance point and bring on in stages.

### Fan Delay Kit (TDR)

911758 - 80-second fan delay

### Liquid Line Solenoid Kit (LLS)

912650 - Required on some models

COPPER WIRE SIZE — AWG (1% Voltage Drop)				
Supply Wire Length-Feet				Supply Circuit
200	150	100	50	Ampacity
6	8	10	14	15
4	6	8	12	20
4	6	8	10	25
4	4	6	10	30
3	4	6	8	35
3	4	6	8	40
2	3	4	6	45
2	3	4	6	50

Wire Size based on N.E.C. for 60° type copper conductors.

# SYSTEM HEATING & COOLING CAPACITIES

## 12 SEER — Extra High Efficiency — Single Phase

Outdoor Unit	Indoor Unit							
Model Number DT3BC-	Model Number C3BA-	Cooling Btuh	SEER	Heating Btuh@47°	Heating Btuh@17°	HSPF	Nominal SCFM	Required Indoor Orifice <sup>(1)</sup>
018KA	030C/U-A (2)	18,000	12.0	17,600	10,800	7.9	675	.053
024K	036C/U-A (2)	24,000	12.0	22,400	12,800	7.2	700	.065
024K	030C/U-B	24,000	12.0	22,400	12,800	7.2	700	.065
030K	036C/U-A+TDR (2)	28,600	12.0	28,400	16,200	7.6	900	.067
030K	036C/U-B+TDR (2)	28,600	12.0	28,400	16,200	7.6	900	.067
036K	042C/U-B (2)	34,600	12.0	34,600	19,700	7.6	1100	.077
042K	048C/U-B+TDR (2)	40,500	12.0	40,500	23,100	7.6	1300	.085
042K	048C/U-C+TDR	40,500	12.0	40,500	23,100	7.6	1300	.085
048K	060C/U-C (2)	48,000	12.0	48,000	27,400	7.6	1600	.093
060K	060C-C+TDR (2)	57,000	12.0	57,000	32,800	7.6	1700	.099

Outdoor Unit	Indoor Unit							
Model Number DT3BC-	Model Number B3B(M,V)-	Cooling Btuh	SEER	Heating Btuh@47°	Heating Btuh@17°	HSPF	Nominal SCFM	Required Indoor Orifice <sup>(1)</sup>
018KA	030K-A	17,600	12.0	17,200	10,200	8.1	675	.053
024K	030K-A	24,000	12.0	22,400	12,800	7.2	700	.065
024K	030K-B	24,000	12.0	22,400	12,800	7.2	700	.065
030K	030K-A+TDR	28,600	12.0	28,400	16,200	7.6	900	.067
030K	036K-B+TDR	28,600	12.0	28,400	16,200	7.6	900	.067
036K	042K-B	34,600	12.0	34,600	19,700	7.6	1100	.077
042K	048K-B+TDR	40,500	12.0	40,500	23,100	7.6	1300	.085
048K	060K-C	48,000	12.0	48,000	27,400	7.6	1600	.093
060K	060K-C+TDR	57,500	12.0	58,000	32,800	7.6	1700	.099

### 13 SEER — (Rating for DT3BC with VSB or LLS)

Model Number DT3BC-	Model Number C3BA-	Cooling Capacity (Btu/h)	SEER Rating	Heating Capacity (Btu/h) @ 47°	HSPF	Heating Capacity (Btu/h) @ 17°	Nominal Airflow (SCFM)	Indoor Orifice Size (in) <sup>(1)</sup>
018KA	030(C,U)-A/B+VSB	18,200	13.0	17,800	8.1	11,000	700	0.053
024K	036(C,U)-B+TDR+LLS	24,200	13.0	22,600	7.3	13,000	700	0.065
024K	030(C,U)-B+VSB	24,200	13.0	22,000	7.8	12,500	720	0.065
030K	042(C,U)-B+TDR+LLS	28,800	13.0	28,600	7.7	16,300	900	0.067
030K	036(C,U)-B+VSB	28,800	13.0	28,000	8.0	15,900	990	0.067
036K	042(C,U)-B+LLS+VSB	35,000	13.0	34,400	8.0	20,000	1,100	0.077
042K	048(C,U)-(B,C)+LLS+VSB	41,500	13.0	41,000	8.0	23,400	1,305	0.085
048K	060(C,U)-C+VSB	48,000	13.0	47,500	8.0	27,000	1,530	0.093

Model Number DT3BC-	Model Number PAH1VM	Cooling Capacity (Btu/h)	SEER Rating	Heating Capacity (Btu/h) @ 47°	HSPF	Heating Capacity (Btu/h) @ 17°	Nominal Airflow (SCFM)	Indoor Orifice Size (in) <sup>(1)</sup>
018KA	030(C,U)-A/B	17,800	13.0	17,400	8.1	10,400	720	0.053
024K	036K-B	24,600	13.0	22,200	7.7	12,500	720	0.065
030K	036K-B	29,000	13.0	28,000	7.7	14,600	885	0.067
036K	048K-B+LLS	35,000	13.0	34,400	8.0	20,000	1,100	0.077
042K	048K-B	41,000	13.0	39,500	7.9	19,700	1,315	0.085
048K	060K-C	48,000	13.0	48,000	7.6	27,400	1,600	0.093
060K	066K-C	57,000	13.0	57,000	7.8	36,400	1,700	0.099

See the current ARI Directory for certified combinations and ratings.

(1) Orifice supplied with outdoor unit.

(2) Available as C3BH multi-position coil.

LLS = Liquid Line Solenoid

TDR = Time Delay Relay

VSB = Variable Speed Blower



CERTIFICATION APPLIES ONLY  
WHEN THE COMPLETE  
SYSTEM IS LISTED  
WITH ARI

We Encourage  
Professionalism



Through Technician  
Certification by NATE