

FG6RA Series

High Efficiency Upflow/Horizontal Gas Furnace

Induced Draft - 80+ AFUE
Input 45,000 - 144,000 Btuh

The high efficiency upflow/horizontal gas furnace may be installed free standing in a utility room, basement, or enclosed in an alcove or closet. The extended flush jacket provides a pleasing "appliance appearance." Design certified by the American Gas Association (AGA) Laboratories and the Canadian Gas Association (CGA) Laboratories. The product is truly designed with the contractor and the consumer in mind.

FEATURES and BENEFITS

- **100% fired and tested** — All units and each component (both mechanical and electrical) are tested on the manufacturing line.
- **Best packaging in the industry** — Unique design assures product will arrive to the homeowner dent free.
- **Clean and quiet operation** — Due to the unique design of in-shot burners, location of inducer, return air vents, and use of insulation.
- **Fixed 30 second blower delay** at burner start-up assures a warm duct temperature at furnace start-up. Adjustable blower off settings (60, 90, 120 and 180 seconds).
- **Fixed 30 second post purge** increases life of heat exchanger.
- **Dependable, hot surface ignitor** — Innovative application of an appliance type ignitor with a 20 year history of reliability.
- **Color coded wire harness** — Designed to fit the components, all with quick-connect fittings for ease of service and replacement.
- **Approved for categories I and III venting systems** — May be common, dedicated, or horizontal vented for maximum flexibility in installation.
- **Tubular primary heat exchanger** — Heavy gauge aluminized steel heat exchanger assures a long life.
- **90 second fixed cooling cycle blower-off delay (TDR)** increases cooling performance when matched with a NORDYNE coil.
- **Variable speed blower kit** is available to maximize air conditioner and heat pump efficiencies. On selected units, SEER ratings up to 14 and HSPF ratings up to 8.5 are ARI listed.
- **Multi-speed direct drive blower** — Designed to give a wide range of cooling capacities. 40VA transformer included.
- **LP convertible** — Simple burner orifice and regulator spring change for ease of convertibility.
- **Diagnostic lights flash to identify limit failure, pressure switch failure, improper ground and polarization, and low flame signal** — for easy troubleshooting.
- **Incorporates integrated control board** with connections for electronic air cleaner, humidifier and twinning.
- **Two piece door design** enhances furnace appearance and uses screw fasteners for easier accessibility.
- **3 amp fuse** protection against low voltage shorts; protects transformer and control board.
- **Low voltage terminal board** for easy field wiring.
- **Components and Controls** — Designing quality into our products means selecting manufacturers that have a reputation for delivering high quality, dependable products.
- **Warranty** — The best in the industry.
 - 5 year limited parts
 - 2 year mileage
 - 2 year labor
 - 20 year limited warranty on heat exchanger

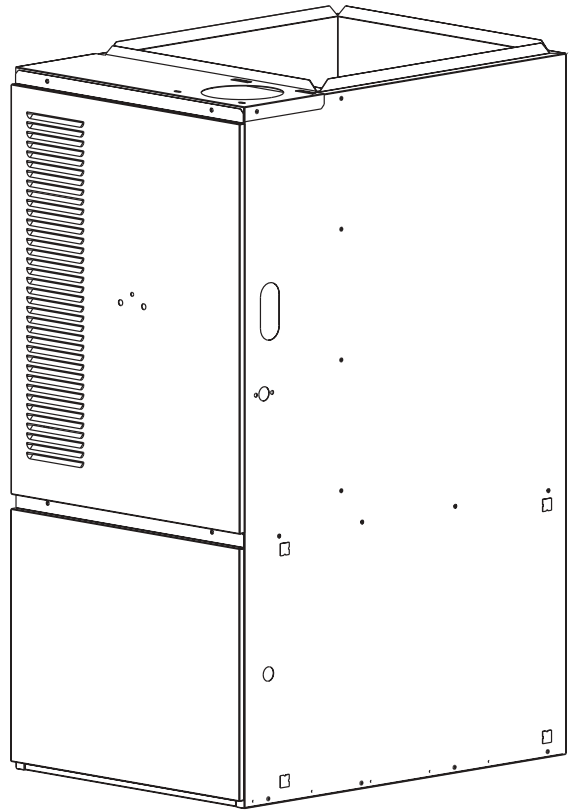

FEATURES

High Efficiency Upflow/Horizontal 80+ Gas Furnace

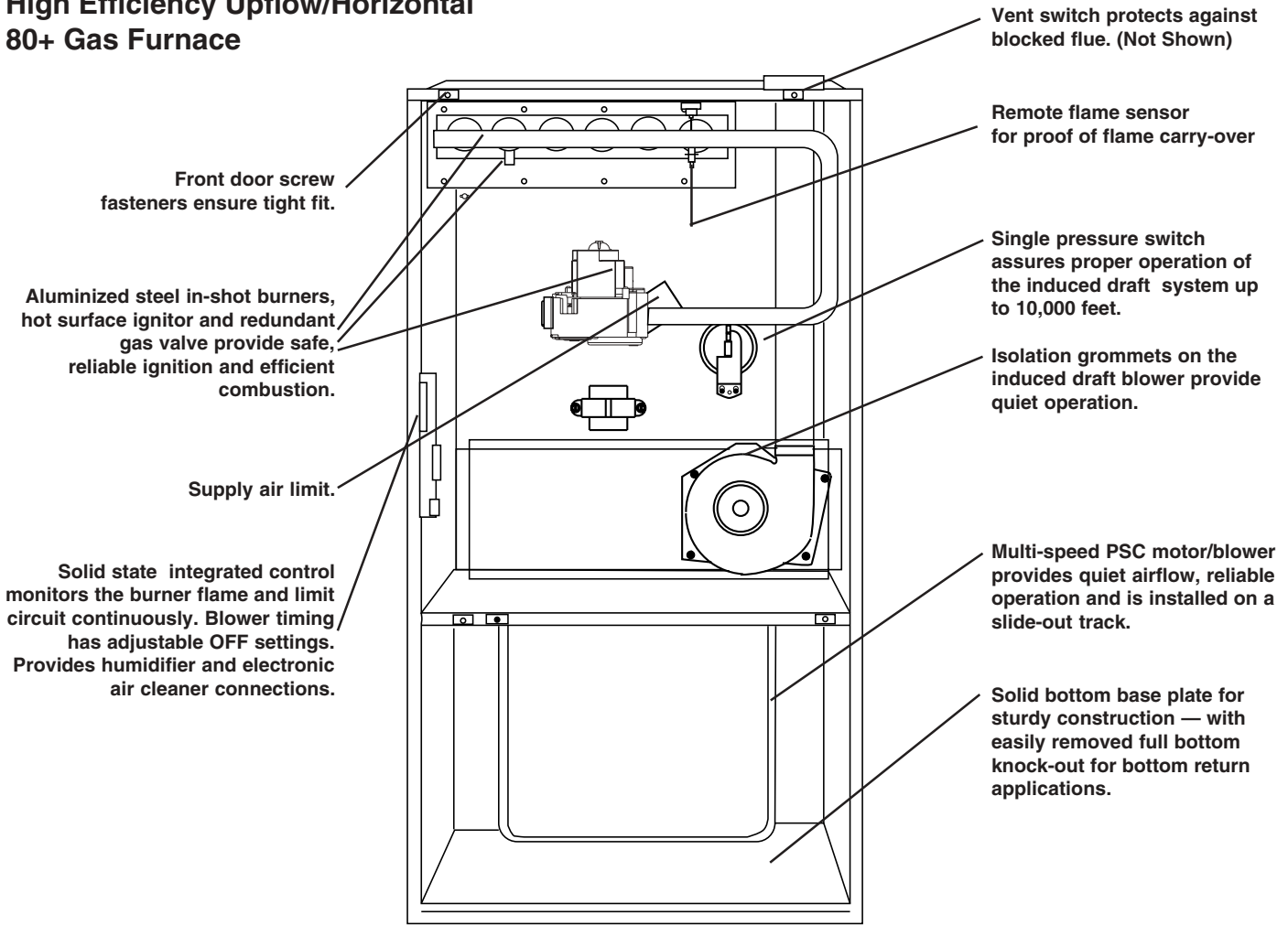

STANDARD EQUIPMENT

Draft inducer; pressure switch; redundant main gas control; hot-surface ignition; timed ON/OFF blower controls (TDR) ; 40VA transformer for air conditioner application; limit controls; solid base plate with knock-out for easy removal; direct drive motor; all models can be converted to use L.P. (propane) gas. Factory approved kits *only* must be used and are available as an optional accessory from your distributor.

SPECIFICATIONS

FG6RA MODEL NUMBERS	-045()08A	-060()12A	-072()12A	-072()16B	-072()17A	-096()12B	-096()16B	-096()20C	-120()16B	-120()20C	-144()20C
Input-Btuh (a)	45,000	60,000	72,000	72,000	72,000	96,000	96,000	96,000	120,000	120,000	144,000
Heating Capacity - Btuh	36,000	48,000	58,000	58,000	58,000	77,000	77,000	77,000	96,000	96,000	115,000
AFUE	80+	80+	80+	80+	80+	80+	80+	80+	80+	80+	80+
Max. Htg. Ext. St. Press. In W.C.	.5	.5	.5	.5	.5	.5	.5	.5	.5	.5	.5
Blower Wheel D x W	10 x 6	10 x 6	10 x 6	10 x 10	10 x 6	10 x 9	10 x 10	11 x 10	10 x 10	11 x 10	11 x 10
Motor H.P. -Speed -Type	1/5-3-PSC	1/3-3-PSC	1/3-3-PSC	1/2-4-PSC	3/4-4-PSC	1/3-3-PSC	1/2-4-PSC	3/4-4-PSC	1/2-4-PSC	3/4-4-PSC	3/4-4-PSC
Motor FLA	2.8	6.0	6.0	7.9	14.0	6.0	7.9	11.1	7.9	11.1	11.1
Temperature Rise Range - °F	45 - 75	45 - 75	45 - 75	40 - 70	45 - 75	50 - 80	50 - 80	40 - 70	50 - 80	45 - 75	45 - 75
Approximate Shipping Wt. - lbs.	123	134	135	152	135	163	163	174	174	182	194

All models are 115 V, 60 HZ. Gas connections are 1/2" N.P.T.

AFUE= Annual Fuel Utilization Efficiency

(a) Ratings to 2000 ft. Over 2000 ft. reduce 4% for each 1000 ft. above sea level

DIMENSIONS

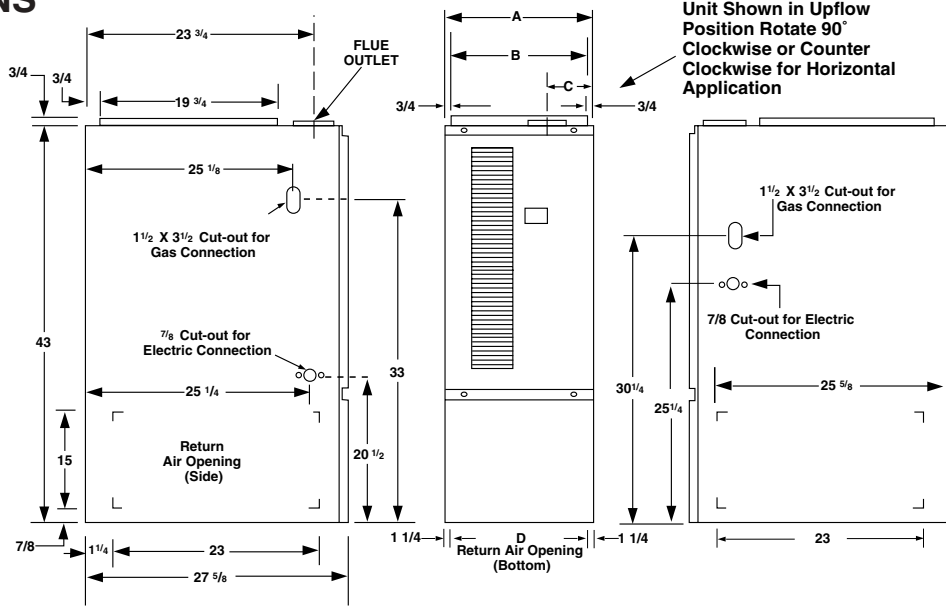

MODEL NUMBER FG6RA-	A (in.)	B (in.)	C (in.)	D (in.)	MODEL NUMBER FG6RA-	A (in.)	B (in.)	C (in.)	D (in.)
045()-08A	14 1/4	12 3/4	3 1/4	11 3/4	096()-16B	19 3/4	18 1/4	3 3/4	17 1/4
060()-12A	14 1/4	12 3/4	3 3/4	11 3/4	096()-20C	22 1/2	21	3 3/4	20
072()-12A	14 1/4	12 3/4	3 3/4	11 3/4	120()-16B	19 3/4	18 1/4	3 3/4	17 1/4
072()-16B	19 3/4	18 1/4	3 3/4	17 1/4	120()-20C	22 1/2	21	3 3/4	20
072()-17A	14 1/4	12 3/4	3 3/4	11 3/4	144()-20C	22 1/2	21	4 1/4	20
096()-12B	19 3/4	18 1/4	3 3/4	17 1/4					

BLOWER PERFORMANCE

Model Number FG6RA-	Heating Input (Btuh)	Motor Speed	Motor HP	External Static Pressure (Inches Water Column)															
				0.1		0.2		0.3		0.4		0.5		0.6		0.7		0.8	
				CFM	Rise	CFM	Rise	CFM	Rise	CFM	Rise	CFM	Rise	CFM	Rise	CFM	Rise	CFM	Rise
045(†)-08A	45,000	High *	1/5	1000	-	970	-	950	-	920	-	870	-	820	-	770	-	700	49
		Medium		760	45	740	46	730	47	720	47	690	49	670	51	640	53	620	55
		Low **		630	54	620	55	610	56	600	57	570	60	540	63	510	67	470	72
060(†)-12A	60,000	High *	1/3	1380	-	1350	-	1310	-	1260	-	1210	-	1150	-	1080	-	1000	45
		Medium		1220	-	1190	-	1160	-	1120	-	1070	-	1020	-	950	48	880	51
		Low **		820	55	800	57	780	58	760	60	730	62	700	65	670	68	640	71
072(†)-12A	72,000	High *	1/3	1380	-	1350	-	1310	-	1260	-	1210	45	1150	47	1080	50	1000	54
		Medium		1220	45	1190	46	1160	47	1120	49	1070	51	1020	53	950	57	880	62
		Low **		820	66	800	68	780	70	760	71	730	74	700	-	670	-	640	-
072(†)-16B	72,000	High *	1/2	1980	-	1910	-	1830	-	1760	-	1660	-	1570	-	1460	-	1350	40
		Med-High		1710	-	1660	-	1610	-	1540	-	1470	-	1390	-	1300	42	1200	45
		Med-Low		1490	-	1470	-	1420	-	1380	-	1320	41	1250	43	1170	46	1090	50
Low **	1270	43	1250	43	1230	44	1190	46	1140	48	1080	50	1010	54	920	59			
072(†)-17A	72,000	High ***	3/4	1950	-	1900	-	1810	-	1810	-	1770	-	1730	-	1700	-	1670	-
		Med-High		1500	-	1450	-	1420	-	1380	-	1340	-	1310	-	1280	-	1250	-
		Med-Low		1160	47	1130	48	1090	50	1060	51	1030	53	980	55	940	58	900	60
Low ****	910	60	870	62	840	64	810	67	770	70	740	73	710	-	680	-			
096(†)-12B	96,000	High *	1/3	1530	-	1450	50	1390	52	1300	56	1220	59	1130	64	1040	70	940	77
		Medium **		1380	52	1320	55	1250	58	1190	61	1100	66	1020	71	920	79	820	-
		Low		930	78	900	80	870	-	820	-	750	-	670	-	580	-	470	-
096(†)-16B	96,000	High *	1/2	1980	-	1910	-	1840	-	1760	-	1680	-	1590	-	1500	-	1410	51
		Med-High		1720	-	1670	-	1610	-	1560	-	1480	-	1410	51	1320	55	1230	59
		Med-Low **		1470	-	1440	50	1410	51	1370	53	1320	55	1270	57	1200	60	1130	64
Low	1270	57	1240	58	1220	59	1190	61	1140	64	1090	66	1040	70	970	75			
096(†)-20C	96,000	High *	3/4	2340	-	2290	-	2280	-	2180	-	2150	-	2080	-	2000	-	1920	-
		Med-High		1910	-	1880	-	1860	-	1830	40	1810	40	1790	40	1770	41	1750	41
		Med-Low		1520	48	1510	48	1490	49	1480	49	1460	50	1440	50	1420	51	1400	52
Low **	1370	53	1350	54	1340	54	1320	55	1300	56	1280	57	1260	57	1230	59			
120(†)-16B	120,000	High *	1/2	1900	-	1830	-	1750	52	1630	56	1580	57	1490	61	1400	65	1320	69
		Med-High**		1720	53	1670	54	1610	56	1560	58	1480	61	1410	64	1320	69	1230	74
		Med-Low		1450	62	1420	64	1380	66	1340	68	1280	71	1220	74	1150	79	1070	-
Low	1260	72	1230	74	1200	75	1170	77	1120	-	1070	-	1020	-	960	-			
120(†)-20C	120,000	High *	3/4	2300	-	2250	-	2190	-	2130	-	2090	-	2040	-	2000	45	1950	46
		Med-High		1910	47	1880	48	1860	49	1830	49	1800	50	1770	51	1740	52	1700	53
		Med-Low **		1540	59	1530	59	1520	60	1500	60	1480	61	1450	62	1420	64	1390	65
Low	1320	69	1310	69	1300	70	1280	71	1260	72	1230	74	1200	75	1170	-			
144(†)-20C	144,000	High *	3/4	2240	49	2190	50	2130	51	2070	52	2020	54	1960	55	1910	57	1850	59
		Med-High**		1900	57	1860	58	1820	60	1780	61	1740	62	1700	64	1660	65	1620	67
		Med-Low		1520	71	1510	72	1490	73	1480	73	1450	75	1420	-	1390	-	1360	-
Low	1330	-	1310	-	1290	-	1280	-	1250	-	1230	-	1210	-	1180	-			

† Can be C or N

Notes: 1. Airflow rates of 1800 CFM or more require two return air connections. Data is for operation with filter(s).

* Factory Set Cooling Speed

2. Temperature rises in the table are approximate. Actual temperature rises may vary.

** Factory Set Heating Speed

3. Temperature rises and airflows for external static pressures greater than 0.5 are for reference only. These conditions are not recommended.

- Not Recommended

MODEL IDENTIFICATION CODE

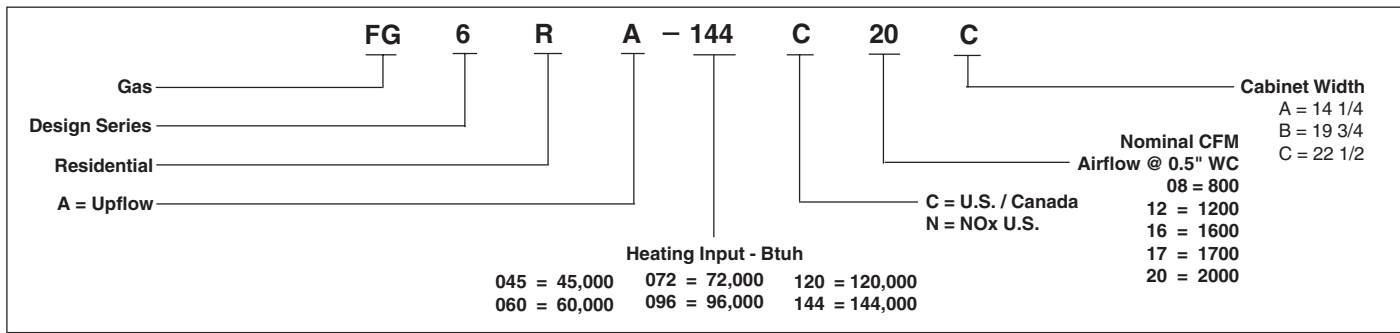

Through-the-Wall VENTING Venting Requirements

These furnaces are approved to use with 3" single wall AL29-4C stainless steel vent pipe in horizontal vent applications, and with the required horizontal vent kit listed below. The pipe is available from the following manufacturers:

- Z-Flex Inc.** - vent brand name (**Z-VENT**)
- Heat-fab Inc.** - vent brand name (**Saf-T Vent**)
- Flex-L International** - vent brand name (**STAR-34 Vent**)

When venting horizontal, this is a Category III furnace, the vent pressure is positive, and the venting system must be sealed in both horizontal and vertical runs.

Model Number FG6RA-	Min. Pipe Size	Reducer Needed	Flue Outlet (in.)	Max. # Elbows	Max. Ft. Vent Pipe
045(-)08A	3"	None	3	4	35
060(-)12A	3"	4" to 3"	4	4	35
072(-)12A	3"	4" to 3"	4	4	35
072(-)16B	3"	4" to 3"	4	4	35
072(-)17A	3"	4" to 3"	4	4	35
096(-)12B	3"	4" to 3"	4	4	35
096(-)16B	3"	4" to 3"	4	4	35
096(-)20C	3"	4" to 3"	4	4	35
120(-)16B	3"	4" to 3"	4	4	35
120(-)20C	3"	4" to 3"	4	4	35
144(-)20C*	3"	4" to 3"	5	3	30

* NOTE: Field supplied special 5" to 4" Reducer Kit required for model FG6RA144C-120.

ACCESSORIES

Kit	Order Number
U.S. LP Conversion Kit (0 to 10,000 ft.)	903616
Canadian LP Gas Conversion Kit (0 to 4,500 ft.)	903617
Fossil Fuel Kit	914762
Side Return Filter Kit	541036
Bottom Return Filter (20/Box)	A Cabinet: 903088 B Cabinet: 903089 C Cabinet: 903090
Horizontal Vent Kit	903196
Internal Side Return Filter Wire	903152
Variable Speed Blower Kit for "B" & "C" Cabinets	903756

VENTING

All models, with the exception of the reduced NOx models, are approved for vertical and horizontal venting applications (see table above). All models may be common vented with a gas water heater. Type B gas vent materials may be used when connected to a vertical vent system. The installation must be in accordance with the venting instructions supplied with the furnace.



We Encourage Professionalism



Through Technician Certification by NATE