

FG6RK Series High Efficiency Downflow Gas Furnace

**Induced Draft - 80+ AFUE
Input 60,000 - 120,000 Btuh**

The high efficiency downflow gas furnace may be installed free standing in a utility room, basement, or enclosed in an alcove or closet. The extended flush jacket provides a pleasing "appliance appearance." Design certified by the American Gas Association (AGA) Laboratories and the Canadian Gas Association (CGA) Laboratories. The product is truly designed with the contractor and the consumer in mind.

Features and Benefits

- **100% fired and tested** - All units and each component (both mechanical and electrical) are tested on the manufacturing line.
- **Best packaging in the industry** - Unique design assures product will arrive to the homeowner dent free.
- **Clean and quiet operation** - Due to the unique design of in-shot burners, location of inducer, return air vents, and use of insulation.
- **Fixed 30 second blower delay** at burner start-up assures a warm duct temperature at furnace start-up. Adjustable blower off settings (60, 120, 160 and 180 seconds).
- **Fixed 30 second post purge** increases life of heat exchanger.
- **Dependable, shock-mounted hot surface ignitor** - Innovative application of an appliance type ignitor with a 20 year history of reliability, assures no callbacks because of handling.
- **Color coded wire harness** - Designed to fit the components, all with quick-connect fittings for ease of service and replacement.
- **Approved for categories I and III venting systems** - May be common, dedicated, or horizontally vented for maximum flexibility in installation.
- **Tubular primary heat exchanger** - Heavy gauge aluminized steel heat exchanger assures a long life.
- **90 second fixed cooling cycle blower-off delay (TDR)** increases cooling performance when matched with a NORDYNE coil.
- **Multi-speed direct drive blower** - Designed to give a wide range of cooling capacities. 40VA transformer included.
- **LP convertible** - Simple burner orifice and regulator spring change for ease of convertibility.
- **Diagnostic lights flash to identify limit failure, pressure switch failure, low flame signal and improper ground and polarization** - for easy troubleshooting.
- **Incorporates new integrated control board** with connections for electronic air cleaner, humidifier and twinning.
- **New door design** enhances furnace appearance and uses screw fasteners for easier accessibility.
- **3 amp fuse** protection against low voltage shorts; protects transformer and control board.
- **Low voltage terminal board** for easy field wiring.
- **Components and Controls** - Designing quality into our products means selecting manufacturers that have a reputation for delivering high quality, dependable products.
- **Warranty** - The best in the industry.
 - 5 year limited parts
 - 2 year mileage
 - 2 year labor
 - 20 year limited warranty on heat exchanger

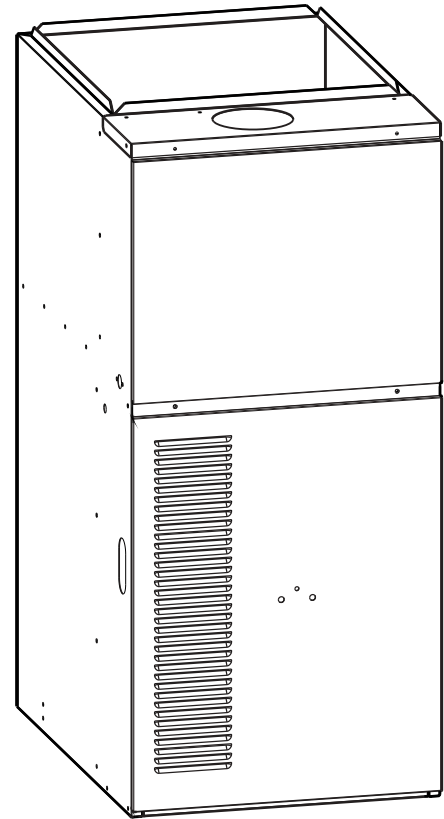

FEATURES

High Efficiency Downflow 80+ Gas Furnace

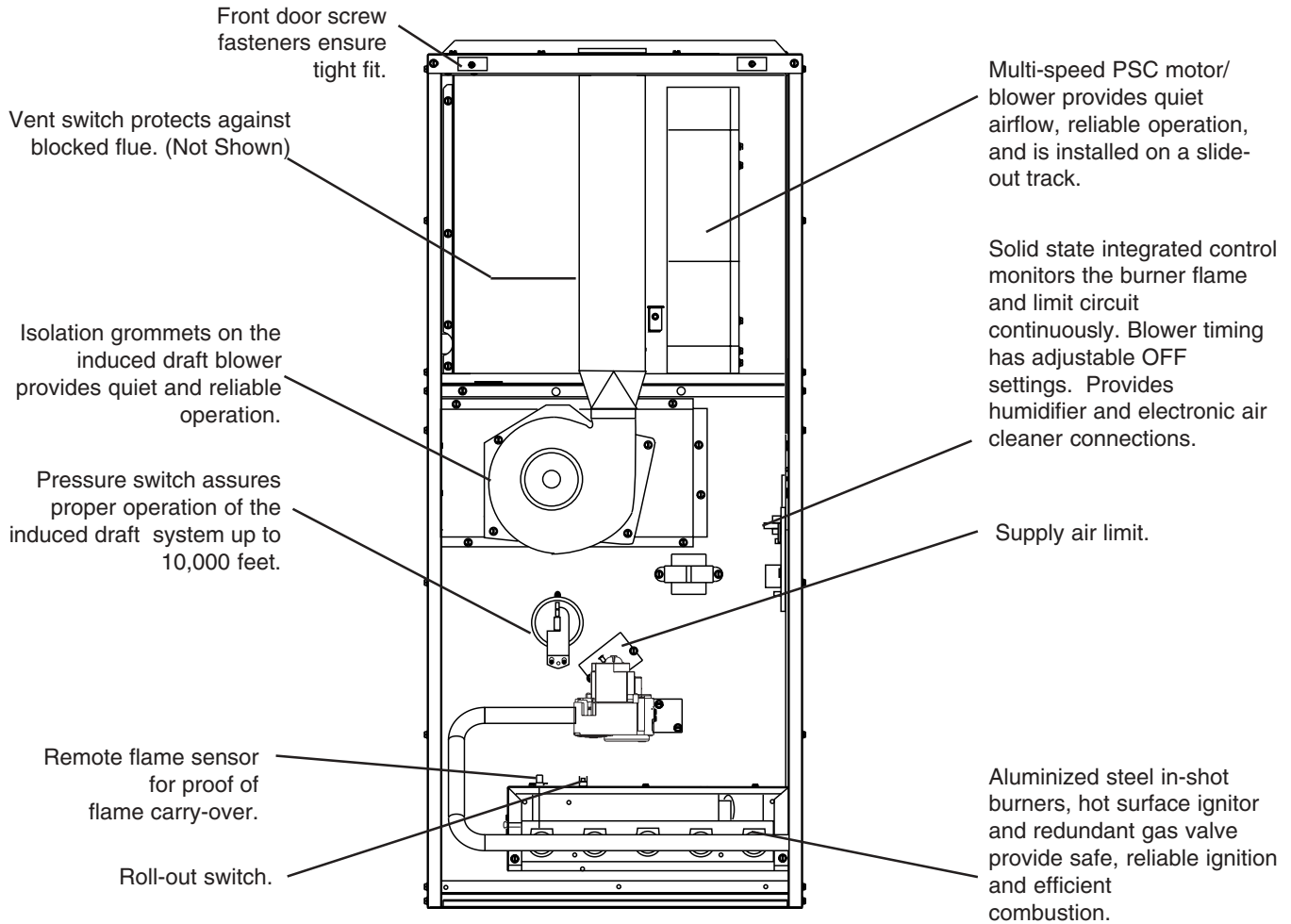

STANDARD EQUIPMENT

Draft inducer; pressure switch; redundant main gas control; hot-surface ignition; timed ON/OFF blower controls (TDR); 40 VA transformer for air conditioner application; limit controls; direct drive motor; all models can be converted to use L.P. (propane) gas. Factory approved kits *only* must be used and are available as an optional accessory from your distributor.

SPECIFICATIONS

FG6RK MODEL NUMBERS	-060C-12A	-072C-12A	-072C-16B	-096C-12B	-096C-16B	-120C-20B
Input-Btuh (a)	60,000	72,000	72,000	96,000	96,000	120,000
Heating Capacity - Btuh	48,000	58,000	58,000	77,000	77,000	96,000
AFUE	80+	80+	80+	80+	80+	80+
Blower D x W	10 x 6	10 x 6	10 x 10	10 x 8	10 x 10	11 x 10
Motor H.P. -Speed -Type	1/3 - 3 - PSC	1/3 - 3 - PSC	1/2 - 4 -PSC	1/3 - 3 -PSC	1/2 - 4 -PSC	3/4 - 4 -PSC
Motor FLA	6.0	6.0	7.9	6.0	7.9	11.1
Maximum Ext. SP - In. W.C.	0.5	0.5	0.5	0.5	0.5	0.5
Temperature Rise Range - °F	35 - 65	45 - 75	35 - 65	45 - 75	40 - 70	40 - 70

Note: All models are 115V, 60 Hz. Gas Connections are 1/2" N.P.T. AFUE = Annual Fuel Utilization Efficiency.

(a) Ratings to 2,000 feet. Over 2,000 feet, reduce 4% for each 1,000 ft. above sea level.

DIMENSIONS

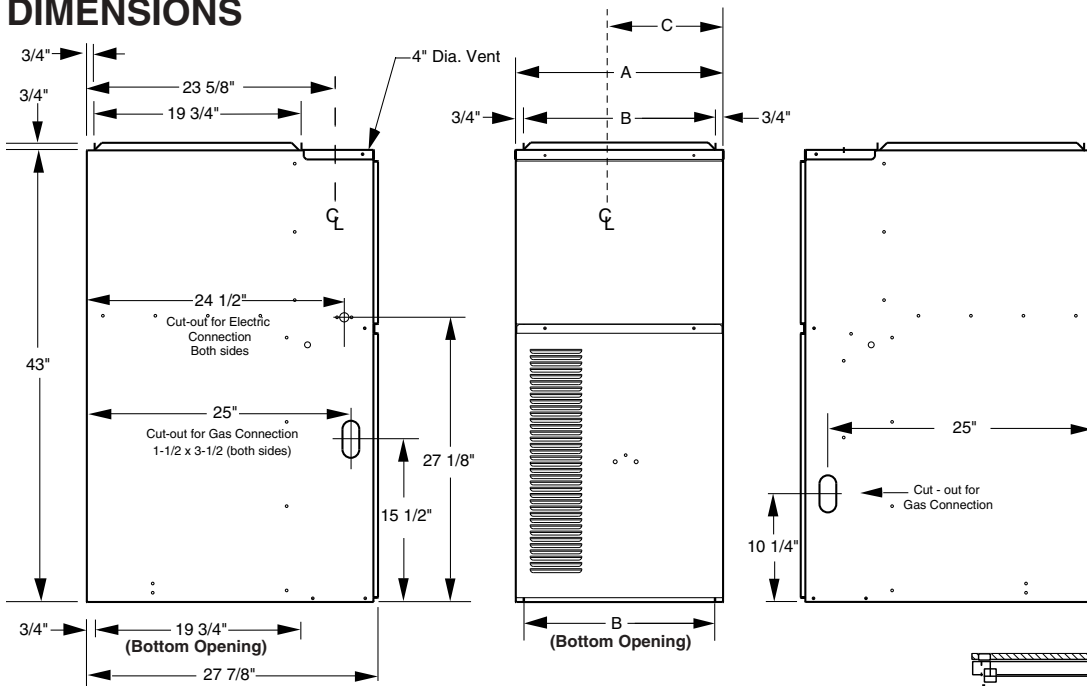

Model Number FG6RK-	Dimensions			Shipping Weights (lbs)
	A inches	B inches	C inches	
060C-12A	14 1/4	12 3/4	5 1/2	134
072C-12A	14 1/4	12 3/4	5 1/2	135
072C-16B	19 3/4	18 1/4	11	147
096C-12B	19 3/4	18 1/4	11	154
096C-16B	19 3/4	18 1/4	11	156
120C-20B	19 3/4	18 1/4	11	182

Downflow Sub-Base

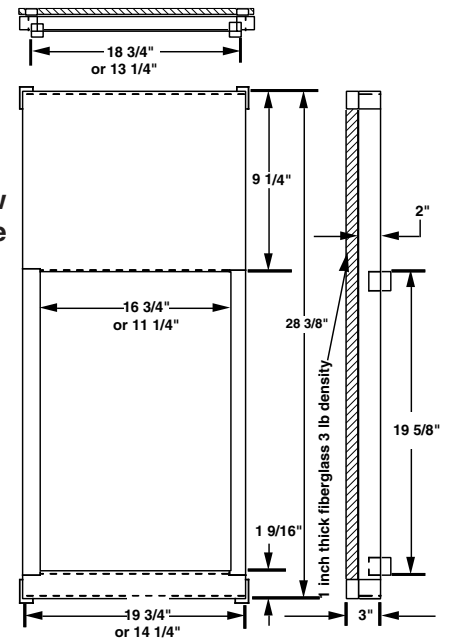

BLOWER PERFORMANCE

Model Number FG6RK-	Heating Input (Btuh)	Motor Speed	Motor HP	External Static Pressure (Inches Water Column)															
				0.1		0.2		0.3		0.4		0.5		0.6		0.7		0.8	
				CFM	Rise	CFM	Rise	CFM	Rise	CFM	Rise	CFM	Rise	CFM	Rise	CFM	Rise	CFM	Rise
060C-12A	60,000	High *	1/3	1380	-	1345	-	1330	-	1260	36	1230	37	1190	38	1160	39	1120	40
		Medium		1180	38	1145	40	1130	40	1110	41	1080	42	1060	43	1040	44	1010	45
		Low **		830	55	810	56	805	56	795	57	780	58	770	59	760	60	750	60
072C-12A	72,000	High *	1/3	1380	-	1345	-	1330	-	1260	-	1230	-	1190	46	1160	47	1120	49
		Medium		1180	46	1145	47	1130	48	1110	49	1080	50	1060	51	1040	52	1010	54
		Low **		830	65	810	67	805	67	795	68	780	70	770	71	760	71	750	72
072C-16B	72,000	High *	1/2	1850	-	1790	-	1775	-	1755	-	1735	-	1700	-	1680	-	1650	-
		Med-High		1460	37	1435	38	1420	38	1400	39	1380	39	1360	40	1340	41	1320	41
		Med-Low		1210	45	1195	45	1180	46	1160	47	1140	48	1120	49	1110	49	1090	50
096C-12B	96,000	High *	1/3	1475	49	1460	50	1445	50	1430	51	1410	51	1400	52	1380	52	1360	53
		Medium **		1200	60	1195	61	1180	61	1165	62	1145	63	1140	64	1120	65	1110	65
		Low		795	-	785	-	770	-	755	-	735	-	720	-	710	-	690	-
096C-16B	96,000	High *	1/2	1950	-	1890	-	1865	-	1835	-	1805	40	1770	41	1730	42	1700	43
		Med-High		1600	45	1580	46	1555	47	1525	48	1495	48	1470	49	1450	50	1420	51
		Med-Low **		1375	53	1360	53	1335	54	1305	56	1275	57	1250	58	1230	59	1200	60
120C-20B	120,000	High *	3/4	2440	-	2395	-	2385	-	2375	-	2360	-	2340	-	2320	-	2300	-
		Med-High		1920	47	1910	47	1900	48	1890	48	1875	48	1870	48	1860	49	1840	49
		Med-Low **		1630	56	1620	56	1610	56	1600	57	1585	57	1580	57	1570	58	1550	58
120C-20B	120,000	Low	3/4	1430	63	1425	64	1415	64	1405	64	1390	65	1380	66	1370	66	1360	67

* Factory Set Cooling Speed
 ** Factory Set Heating Speed
 - Not Recommended

Notes: 1. Airflow rates of 1800 CFM or more require two return air connections. Data is for operation with filter(s).
 2. Temperature rises in the table are approximate. Actual temperature rises may vary.
 3. Temperature rises and airflows for external static pressures greater than 0.5 are for reference only. These conditions are not recommended.

MODEL IDENTIFICATION CODE

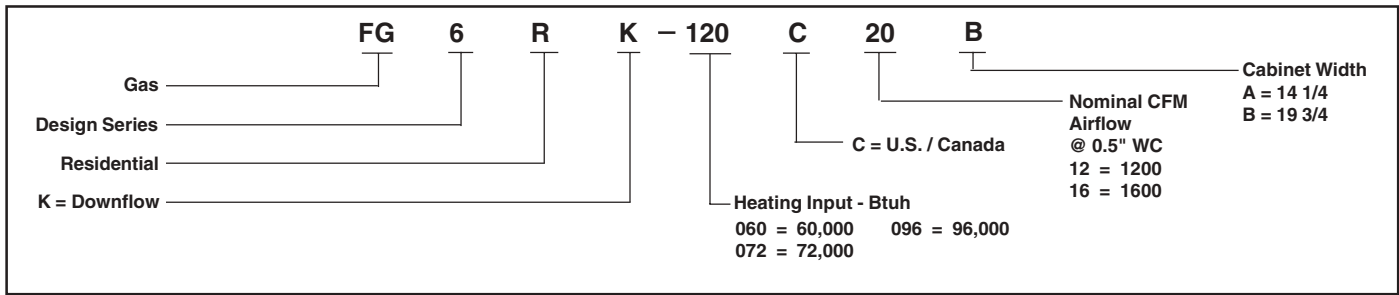

HORIZONTAL VENTING

These furnaces are approved to use with 3" single wall Z-AL29-4C stainless steel vent pipe in horizontal vent applications. The pipe is available from the following manufacturers:

Z-Flex Inc. - vent brand name (**Z-VENT**)

Heat-fab Inc. - vent brand name (**Saf-T Vent**)

Flex-L International - vent brand name (**STAR-34 Vent**)

Model Number FG6RK-	Min. Pipe Size	Reducer Needed	Flue Outlet (in.)	Max. # Elbows	Max. Ft. Vent Pipe
060()-12A	3"	4" to 3"	4	4	35
072()-12A	3"	4" to 3"	4	4	35
072()-16B	3"	4" to 3"	4	4	35
096()-12B	3"	4" to 3"	4	4	35
096()-16B	3"	4" to 3"	4	4	35
120()-20B	3"	4" to 3"	4	4	35

ACCESSORIES

Kit	Order Number
U.S. LP Conversion Kit (0 to 10,000 ft.)	903616
Canadian LP Gas Conversion Kit (0 to 4,500 ft.)	903617
Fossil Fuel Kit	914762
Horizontal Vent Kit	903196
Variable Speed Blower Kit for "B" & "C" Cabinets	903756

VENTING

All models are approved for vertical or horizontal venting applications (See table above). All models may be common vented with a gas water heater. Type B gas vent materials may be used when connected to a gravity (vertical) vent system. The installation must be in accordance with the venting instructions supplied with the furnace.



We Encourage
Professionalism



Through Technician
Certification by NATE