

TECHNICAL SPECIFICATIONS

B3BV Series Air Handler

10 and 12 SEER Manufactured Housing System
24,000 - 66,000 Btuh (Heat Pump & Air Conditioner)

The B3BV Series air handler, when combined with our heat pump or air conditioner, offers a full line of quality, split system heating and cooling equipment.

FEATURES and BENEFITS

- **Multi-speed**– Gives flexibility of installation.
- **Ease-of-Service** – Plug-in wire connections and built-in filter rack makes the air handler easy to service.
- **Insulation** – provides quiet operation.
- **Breaker Accessibility** – Breaker accessible from front of unit when heater is applied.
- **No Fasteners on sides or back** – Smooth surfaces for installations.

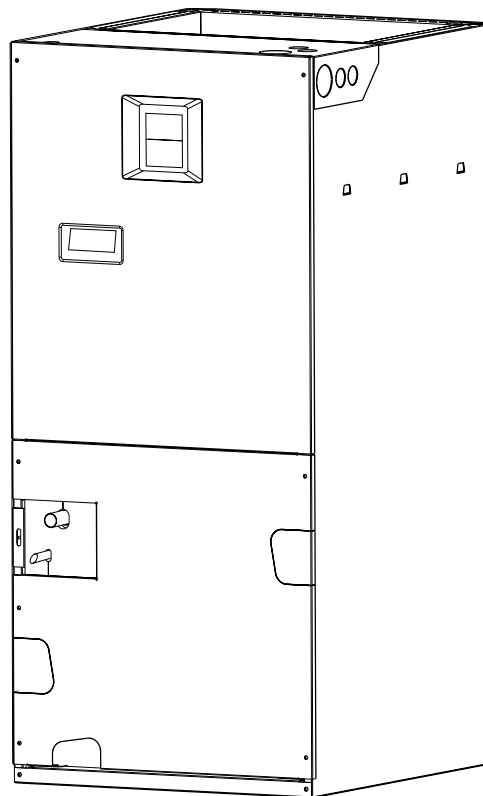

MODEL IDENTIFICATION CODE

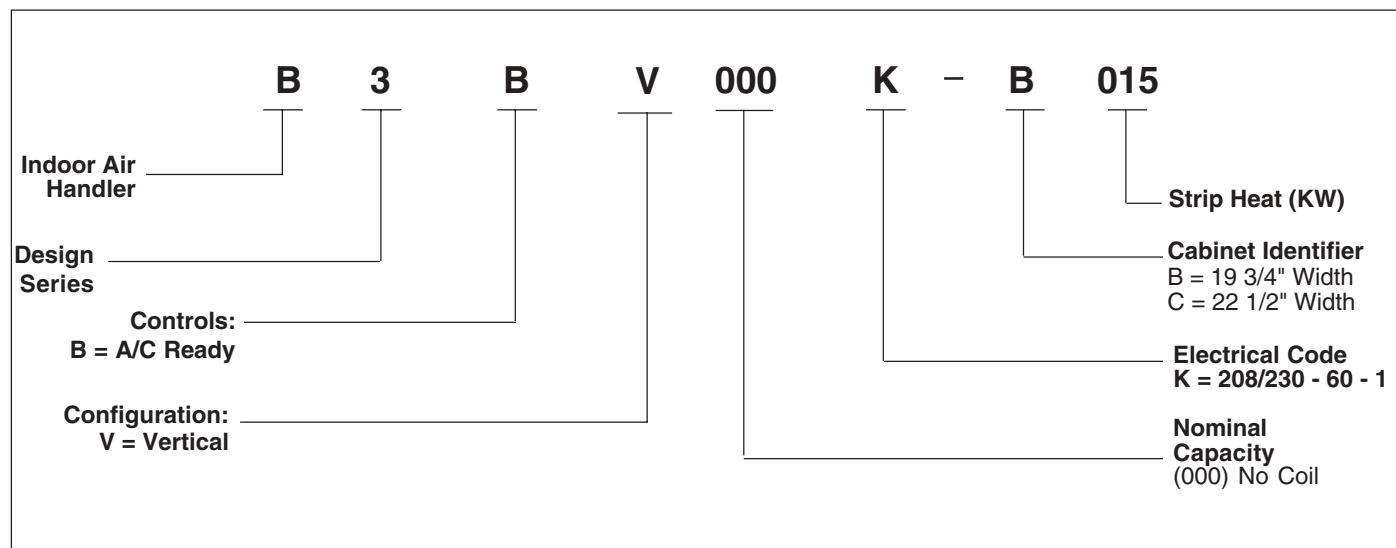

SPECIFICATIONS

Model B3BV	B-10	B-15	C-20
Nominal Blower Size (DxW)	10 x 8	10 x 8	10 x 10
(H.P. - Speed - Type)	1/3 - 4 - PSC	1/3 - 3 - PSC	3/4 - 3 - PSC
Filter Size	18 x 20 x 1	18 x 20 x 1	20 x 20 x 1

ACCESSORIES

Description	Order Number
Downflow Adapter Kit, B cab	917343
Downflow Adapter Kit, C cab	917344
Single Circuit Adapter Kit	913874

