



# INSTALLATION INSTRUCTIONS

---

## DESIGNER 36 FIREPLACES

---

36" Wood Burning Fireplaces  
P/N 800,018M REV. D 04/2002

### *MODELS*

*DM36HCI*

This installation manual will enable you to obtain a safe, efficient and dependable installation of your fireplace system. Please read and understand these instructions before beginning your installation.

Do not alter or modify the fireplace or its components under any circumstances. Any modification or alteration of the fireplace system, including but not limited to the fireplace, chimney components and accessories, may void the warranty, listings and approvals of this system and could result in an unsafe and potentially dangerous installation.

**IMPORTANT! TO ASSURE PROPER ALIGNMENT OF GLASS DOORS:  
INSTALL THIS FIREPLACE IN A SQUARE AND PLUMB CONDITION,  
USING SHIMS AS NECESSARY AT SIDES AND/OR BOTTOM.**

**PLEASE RETAIN THIS MANUAL FOR FUTURE REFERENCE.**

**RETAIN THESE INSTRUCTIONS  
FOR FUTURE REFERENCE**



WH Report No. 764-12354

## TABLE OF CONTENTS

Safety Rules .....	page 2
Tools and Building Supplies .....	page 2
Precautions .....	page 3
Introduction .....	page 3
Clearances/Height Requirements .....	page 3
Chimney System .....	page 3
Assembly Outline .....	page 4
Location of Fireplace .....	page 4
Assembly Steps .....	page 4
Preinstallation Notes .....	page 5
Clearances .....	page 5
Installing the Fireplace .....	page 5
Fireplace Specifications .....	page 6
Framing Specifications .....	page 7
Installing the Chimney System .....	page 8
Ten Foot Rule Summary .....	page 10
Chimney Component Calculations ...	page 11
Special Offset Instructions .....	page 11
30° Offset through Floor/Ceiling .....	page 11
Offset Calculations .....	page 11
Vertical Elevation Chart .....	page 12
Offset Elevation Chart .....	page 13
Installing Offsets .....	page 14
Optional Equipment Considerations .	page 14
Blower Kit .....	page 14
Combustion Air Kits .....	page 15
Gas Line Connection .....	page 15
Glass Doors .....	page 16
Cold Climate Insulation .....	page 16
Fireplace Finishes .....	page 16
Mantels and Trim .....	page 16
Hearth Extensions/Wall Shields .....	page 16
Finish Requirements .....	page 18
Installation Components .....	page 18

### IMPORTANT: PLEASE READ AND UNDERSTAND THESE RULES TO FOLLOW FOR SAFETY.

1. Before starting your fireplace installation, read these installation instructions carefully to be sure you understand them completely and in entirety. Failure to follow them could cause a fireplace malfunction resulting in serious injury and/or property damage.

2. Always check your local building codes. The installation must comply with all local, regional, state and national codes and regulations.

3. This fireplace must be installed with FireCraft's FTF8 (8" inside diameter) Chimney System only. These systems are intended for use in any application where a traditional masonry type fireplace would apply. The chimney system must always vent to the outside of the building.

4. To ensure a safe fireplace system and to prevent the build-up of soot and creosote, inspect and clean the fireplace and chimney prior to use and periodically during the heating season.

5. Use solid fuel only. DO NOT use artificial wax based logs, chemical chimney cleaners or flame colorants in your fireplace.

**Never burn treated construction lumber or scraps. These woods burn excessively hot and may contain chemicals used to treat insects and fungus. When burned, these chemicals can pose a significant hazard.**

6. DO NOT use charcoal or coal under any circumstances.

7. NEVER use gasoline, gasoline-type lantern fuel, kerosene, charcoal lighter fluid, or similar liquids to start or "freshen up" a fire in this fireplace. Keep any flammable liquids a safe distance from the fireplace.

8. NEVER leave children unattended when there is a fire burning in the fireplace.

9. Always keep flue damper open when heat is present in the fireplace.

10. Before servicing, allow the fireplace to cool. Always shut off any electricity or gas to the fireplace while working on it. This will prevent any possible electrical shock or burns.

11. This fireplace is not intended to heat an entire home or be used as a primary heat source. It is designed to ensure homeowner comfort by providing supplemental heat to the room.

12. Always ensure an that adequate supply of replacement combustion air from the outside of the house is accessible to the fire to support normal combustion. Fireplaces consume large volumes of air during the normal combustion process. In the event the home is tightly sealed with modern energy efficient features, the optional combustion air kit may not provide all the air required to support combustion.

The manufacturer is not responsible for any smoking or related problems that may result from the lack of adequate combustion air. It is the responsibility of the builder/contractor to ensure that adequate combustion air has been provided for the fireplace.

13. DO NOT use a fireplace insert or any other products not specified herein by the manufacturer for use with this fireplace. All gas log sets must be operated with the damper clamped open. "Vent-Free" logsets may not be used in manufactured home installations.

14. "Smoke free" operation is not warranted nor are we responsible for inadequate system draft caused by mechanical systems, general construction conditions, inadequate chimney heights, adverse wind conditions and/or unusual environmental factors or conditions beyond our control.

15. Never, under any circumstances, install a fireplace, chimney component or any accessories, that has visible or suspected physical damage as a result of handling or transportation. These items should be inspected by your distributor or qualified factory representative to ensure safe condition. When in doubt, consult your distributor.

16. For additional safety considerations and complete operating instructions, refer to the Care and Operation Manual provided with the fireplace.

### TOOLS AND BUILDING SUPPLIES NORMALLY REQUIRED

Tools should include:

- Phillips screwdriver
- Hammer
- Saw and/or sabersaw
- Level
- Measuring tape
- Plumb line
- Electric drill and bits
- Pliers
- Square

Building supplies:

- Framing materials
- Wall finishing materials
- Caulking materials (noncombustible)
- Fireplace surround and hearth extension materials (noncombustible)

## PRECAUTIONS

**Note:** These fireplace systems are not difficult to install. However, in the interest of safety, it is recommended that the installer be a qualified or certified "tradesman" familiar with commonly accepted fireplace installation and safety techniques as well as prevailing local codes.

The most important areas of concern dealing with the installation of factory-built fireplaces are clearances to combustible materials, proper assembly of component parts, height of the chimney system, the proper use of accessories supplied by the manufacturer and the techniques employed in using finishing materials applied to the wall surrounding the fireplace, hearth extensions and wall shields. Each of these topics will be covered in thorough detail throughout this manual. Please give each your special attention as you progress with your installation.

## INTRODUCTION

### General Information

These fireplaces are conventional radiant heat fireplaces with standard bar grates, an outside combustion air kit and optional decorative glass doors.

## TYPICAL INSTALLATION

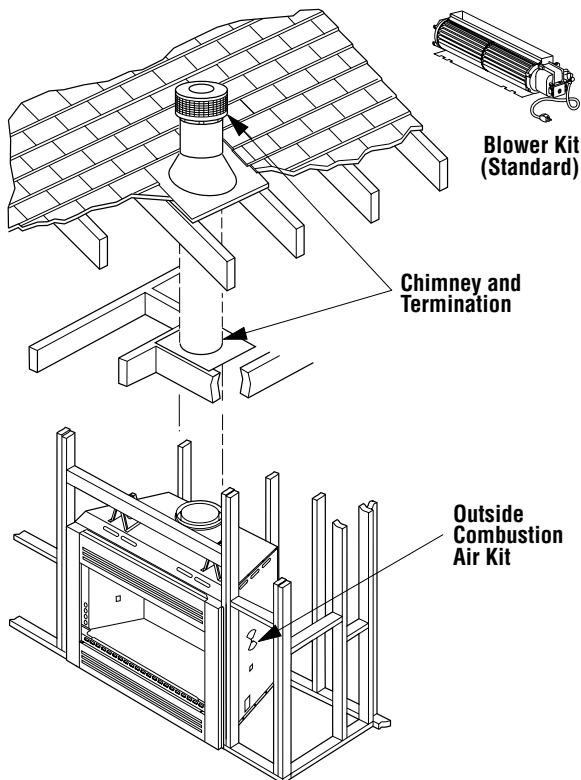


Figure 1

These models are designed as heat circulating fireplaces and may be fitted with accessory fans.

**Note:** Illustrations shown reflect "typical" installations with nominal dimensions and are for design and framing reference only. Actual installations may vary due to individual design preferences. However, always maintain minimum clearances to combustible materials and do not violate any specific installation requirements.

These fireplaces have been tested and listed by Warnock Hersey (Report No. 764-12354) to U.L. standard 127. These units are intended for installation in residential homes and other buildings of conventional construction including commercial, not in mobile homes.

These fireplace systems are designed for installation in accordance with the National Fire Protection Standard for chimneys, fireplaces and solid fuel burning appliances; NFPA 211 and in accordance with codes such as the BOCA Basic/National Codes, the Standard Mechanical Code and the Uniform Building Codes.

NOTE: DIAGRAMS & ILLUSTRATIONS NOT TO SCALE.

**WARNING: FAILURE TO USE MANUFACTURE PROVIDED PARTS, VARIATIONS IN TECHNIQUES AND CONSTRUCTION MATERIALS OR PRACTICES OTHER THAN THOSE DESCRIBED IN THIS MANUAL MAY CREATE A FIRE HAZARD AND VOID THE LIMITED WARRANTY.**

When complete these fireplace systems consists of four basic "sub-systems":

1. The Fireplace
2. The Chimney and Termination
3. The Optional Glass Doors
4. The Combustion Air Kit

## CLEARANCES AND HEIGHT REQUIREMENTS

The fireplace may be placed on or near normal construction materials\*. The combustion air kit, firestop spacer and roof flashing (not chase flashings) may be placed directly on or against normal construction materials.\* The chimney requires a minimum 2" air space to combustibles and the fireplace outer wrapper requires a minimum 1" air space to combustibles. A combustible mantle may be installed 12" above the opening of the fireplace as per NFPA 211, Section 7-2.3.3.

The minimum installed height of the completed fireplace system is 10' 6". The maximum height is 40' 0". See the Chimney Height section on page 4 for more information.

The fireplace and chimney system must be enclosed when installed in or passing through a living area where combustibles or people may come in contact with it. This is important to prevent possible personal injury or fire hazard.

For questions, please call your distributor or the manufacturer. Special restrictions apply to the front and facing of the fireplace and nearby walls (See pages 16, 17 and 18).

## CHIMNEY SYSTEM

These fireplaces are designed and code listed for use with FireCraft's FTF8 chimney System only. Always use FireCraft's FTF8 chimney components with these fireplaces. Do not modify or alter these components as this may cause a potential serious hazard and void the Warranty.

\*Construction Materials:

- framing materials
- paneling
- particle board
- flooring
- millboard
- dry wall
- plywood
- etc.

**WARNING: DO NOT OBSTRUCT THE COLLAR OPENINGS AROUND THE BASE OF THE CHIMNEY AT THE TOP OF THE FIREPLACE. NEVER USE BLOWN INSULATION TO FILL THE CHIMNEY ENCLOSURE.**

**WARNING: IF INSULATION IS USED, THE FIREPLACE MUST NOT BE PLACED DIRECTLY AGAINST IT. INSULATION OR VAPOR BARRIERS, IF USED, MUST FIRST BE COVERED WITH GYPSUM BOARD, PLYWOOD, PARTICLE BOARD OR OTHER MATERIAL TO ASSURE INSULATION AND VAPOR BARRIERS REMAIN IN PLACE.**

**WARNING: DO NOT PACK OR FILL REQUIRED AIR SPACES WITH INSULATION OR OTHER MATERIAL. NO MATERIAL IS ALLOWED IN THESE AREAS. SECURE THE AIRSPACE AROUND THE CHIMNEY WITH THE FIRESTOP/THIMBLE BEFORE COMPLETING THE INSTALLATION. MAINTAIN 1" CLEARANCE BETWEEN CHIMNEY AND THIMBLE.**

*Note: Do not insulate the chimney enclosure cavity with blown or fill type insulation materials.*

*Note: Local codes may not require firestopping at the ceiling levels for outside chase installations. However, it is recommended for safety and the reduction of heat loss.*

### Chimney Height

The total height of your completed fireplace system from the surface the fireplace rests on to the chimney top must not exceed 40' and must also meet minimum height requirements. Refer to the minimum system height chart.

#### Minimum System Height

Firecraft's FTF8 Pipe	
Vertical Installation	10' 6"
One Offset	12' 0"
Two Offsets	35' 0"

### Chimney Enclosure

Construct a box-like framed structure to surround the fireplace and chimney within the confines of the manufactured home, not necessarily above the roof line. As with all chimney installations, avoid overhead obstructions such as trees, power lines, etc. The chimney/fireplace enclosure should be constructed and insulated just like any outside wall. In a cold climate, we recommend the base of the chimney/fireplace enclosure should also be insulated between the solid continuous floor beneath the fireplace and the chase bottom. Insulation in a cold climate installation is not required for safety.

#### ASSEMBLY OUTLINE Before You Start

Check your inventory list to be sure you have all the necessary parts supplied in good usable condition. Check also for any concealed damage.

Check the operation of the damper. The damper is controlled through the use of a control lever located within the firebox opening at the top center in front of the firebox lintel (Figure 2). The control lever snaps into place at either extreme of its range of motion. When locked in position all the way Down (to the front), the damper is open. When locked in position all the way Up (to the rear), the damper is closed.

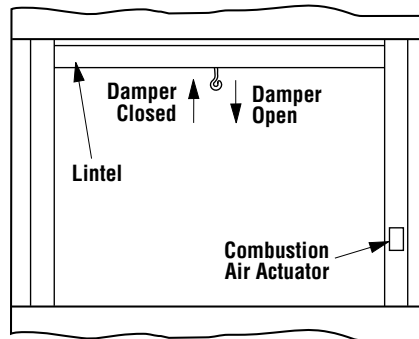


Figure 2

#### LOCATION OF FIREPLACE

Carefully select the proper location for heat circulation, aesthetics, chimney obstructions and clearance to side wall(s). With proper pre-planning, a slight adjustment of a few inches can save considerable time and expense later during construction and assembly.

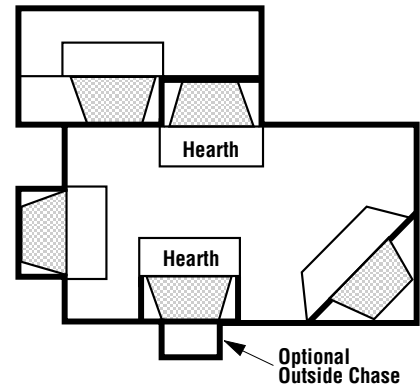


Figure 3

Carefully consider the position of the fireplace opening with respect to the location of adjacent or nearby stairwells, bath or kitchen exhaust fans and/or return air registers for forced air furnaces/air conditioners that could cause a smoking fireplace condition if the house is tightly insulated.

When locating the fireplace, consideration must be given to combustibles and final finishing. See Figure 4 and confine the final location of combustible finish materials to the "Safe Zone".

DO NOT permanently place furniture or other items such as decorative pillows within 60" of the fireplace front face.

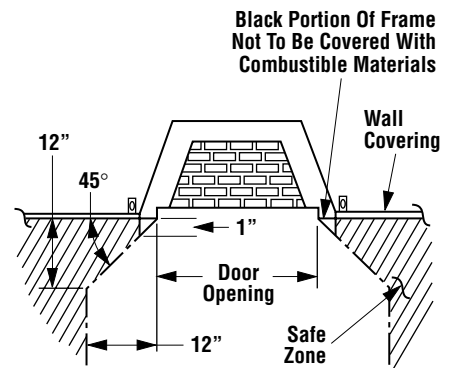


Figure 4

#### ASSEMBLY STEPS

*Note: The following steps represent the normal sequence of installation. Each installation is unique, however, and might require a different sequence.*

1. Position firebox prior to framing or into prepared framing.
2. Install the chimney system.

3. Connect house wiring to the fireplace for later attachment of optional blower.

4. Install optional outside combustion air kit.

5. Plumb gas line if a decorative gas appliance will be used. (Gas connections should only be performed by an experienced, licensed/certified tradesman.)

6. Complete the installation, finish wall material, surround and hearth extension to your individual taste.

7. Assemble and attach optional glass door assembly.

Study the three dimensional illustration (*refer to Figure 1*) to get a general idea of each element of your fireplace system.

## PRE-INSTALLATION NOTES

The fireplace may be installed directly on a combustible floor or raised on a platform of an appropriate height. Do not place fireplace on carpeting, vinyl or other soft floor coverings. It may, however, be placed on flat wood, plywood, particle board or other hard surfaces. Be sure fireplace rests on a solid continuous floor or platform with appropriate framing for support and so that no cold air can enter the room from under the fireplace.

The fireplace may be positioned and then the framing built around it, or the framing may be constructed and the fireplace positioned into the opening.

Usually, no special floor support is needed for the fireplace, however, to be certain:

1. Estimate the total weight of the fireplace system including chimney and surround materials such as brick, stone, etc., to be installed. Shipping weights for the fireplace may be found on page 18.

2. Measure the square footage of the floor space to be occupied by the system, surrounds and hearth extensions.

3. Note the floor construction, i.e. 2 x 6's, 2 x 8's or 2 x 10's, single or double joists, type and thickness of floor boards.

4. Use this information and consult your local building code to determine if you need additional support.

**CAUTION: DO NOT BLOCK THE HEAT-CIRCULATING AIR INLET AND OUTLET PORTS ON CIRCULATING MODELS. DOING SO MAY RESULT IN A POTENTIAL FIRE HAZARD.**

**CAUTION: THE STRUCTURAL INTEGRITY OF THE MANUFACTURED HOME FLOOR, WALL, CEILING AND ROOF MUST BE MAINTAINED.**

The firestop thimble supplied with the unit must be used on a manufactured home installation. The firestop thimble must extend completely through the roof cavity to the outermost plane of the roof (*See Figures 22,23 and 24*). Maintain 1" clearance between the thimble and the chimney.

If you plan to raise the fireplace and hearth extension, build the platform assembly then position fireplace and hearth extension on top. Secure the platform to the floor to prevent possible shifting.

## CLEARANCES

Minimum clearance to combustibles for the appliance is as follows: sides and back - 1" (25 mm), floor - 0" (0 mm), adjacent wall - 12" (305 mm), ceiling - 37 1/2" (953 mm).

## INSTALLING THE FIREPLACE

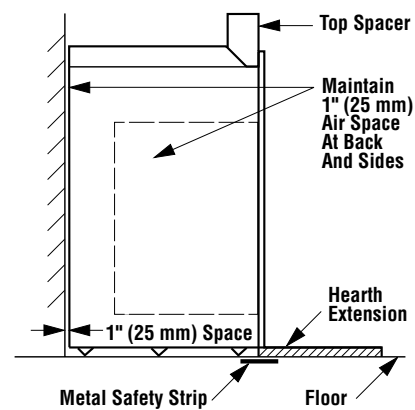
**IMPORTANT: Plated polished brass glass doors may have a plastic covering over all brass pieces for protection during shipping and handling. The plastic covering should be removed after installation of the fireplace before its use. Under the plastic covering is a protective lacquer coating which should not be removed. In some instances, if it is removed, irreversible damage to the brass finish could occur.**

**Step 1.** Slide the fireplace into prepared framing or position fireplace in its final position and frame later.

The fireplace may not be recessed into a combustible floor. Maintain the floor to hearth clearance established by the fireplace lower front face.

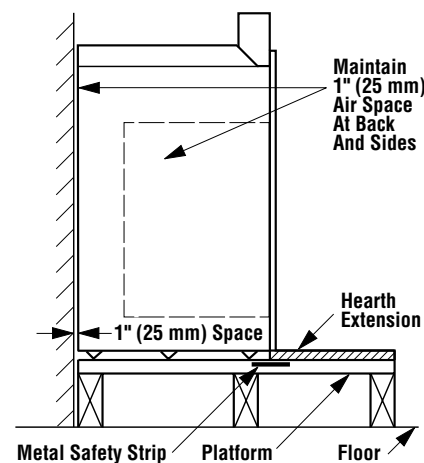
**Step 2.** Insert the provided metal safety strips, beneath the fireplace as illustrated (*Figures 5, 6 and 7*). The safety strips should overlap 1/2" for continual coverage of the floor.

**Note:** Safety strips are not required when fireplace rests on a noncombustible surface.



**Note:** Hearth extensions must not interfere with circulating grillwork

**Figure 5**



**Note:** Hearth extensions must not interfere with circulating grillwork

**Figure 6**

**Note:** Install the hearth extension only as illustrated (*see pages 16, 17 and 18*).

The safety strips should extend from front of the fireplace at least 1 1/2" and should extend to be at least flush with the sides. In the event a wooden support is used to elevate the fireplace above the floor, a "Z" type safety strip should be fabricated and used to protect the front surface of the wood support as well as the floor beneath the hearth extension (*Figures 7 and 8*). The safety strips should be tacked down to prevent possible movement.

**Note:** The "Z" type safety strip is not supplied.

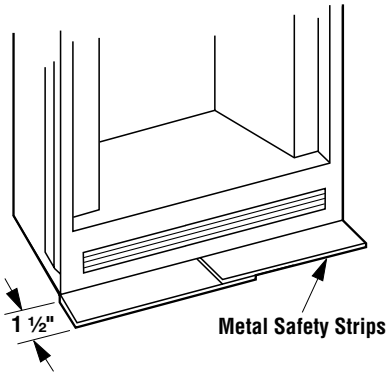


Figure 7

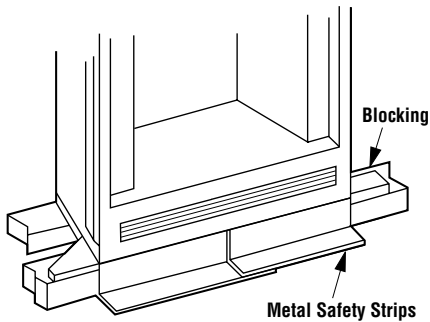


Figure 8

**Step 3.** Refer to fireplace drawings and specifications on pages 6 and 7 for framing dimensions and details. Frame appliance enclosure as illustrated in Figures 10 through 13 on page 7.

**IMPORTANT: UNDER NO CIRCUMSTANCES CAN THE FIREPLACE TOP SPACERS (FIGURE 9) BE REMOVED OR MODIFIED, NOR MAY YOU NOTCH THE HEADER TO FIT AROUND OR BE INSTALLED LOWER THAN THE SPACERS. THE HEADER MAY BE IN DIRECT CONTACT WITH THE TOP SPACERS BUT MAY NOT BE SUPPORTED BY THEM.**

**Note:** The framed depth, 21 3/4" (552 mm) from a framed wall, must always be measured from a finished surface. If a wall covering such as drywall is to be attached to the rear wall, then the 21 3/4" (552 mm) must be measured from the drywall surface. It is important that this dimension be exact.

If the appliance is to be elevated above floor level, a solid continuous platform must be constructed.

The header may rest on the top metal spacers, but must not be notched to fit around them.

Consult all local codes.

## FIREPLACE SPECIFICATIONS

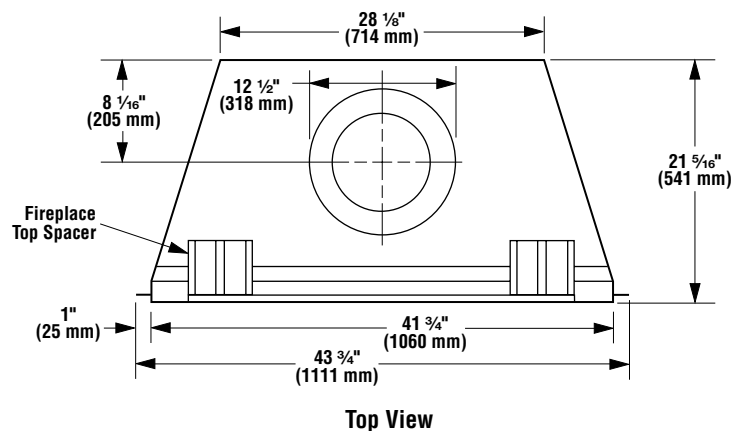
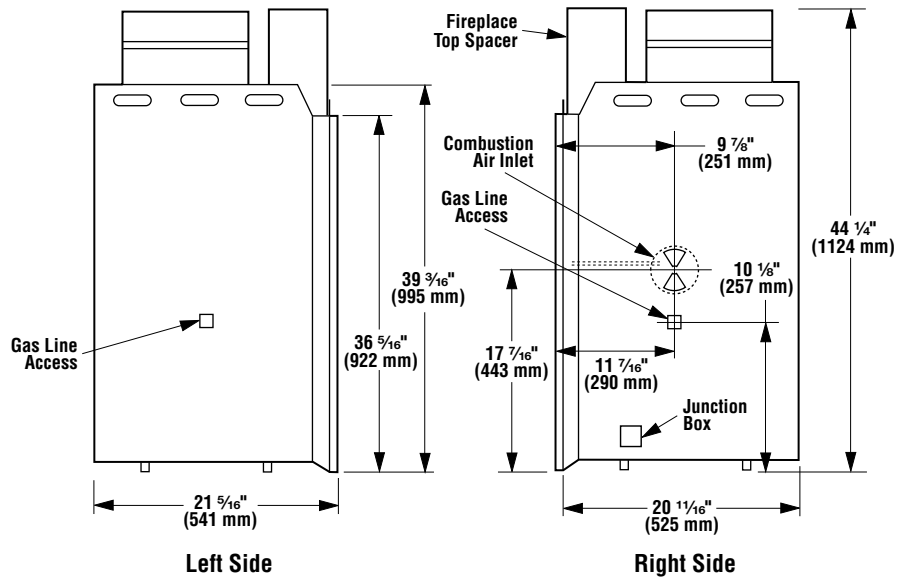
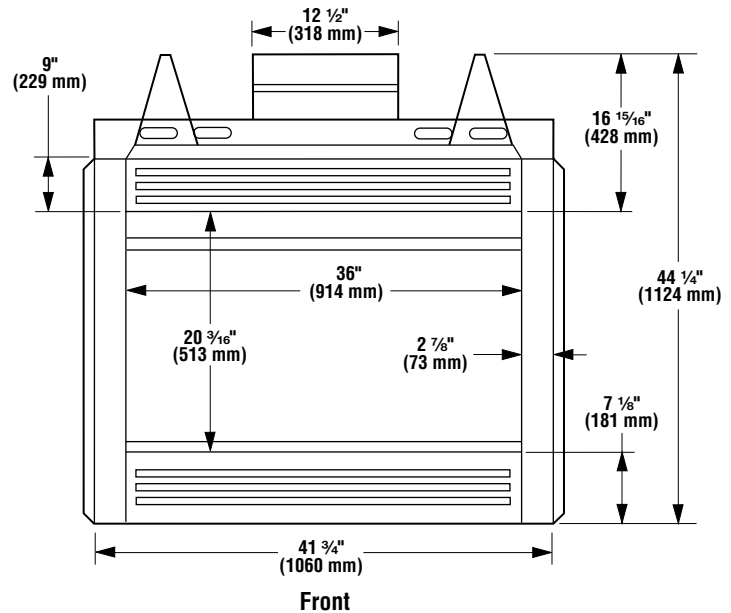


Figure 9

NOTE: DIAGRAMS & ILLUSTRATIONS NOT TO SCALE.

# FRAMING SPECIFICATIONS

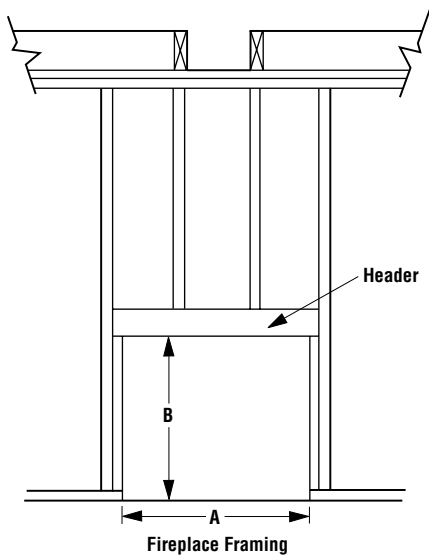


Figure 10

## Framing Dimensions

A	43"	1092 mm
B	44 1/2"	1130 mm
C	29 1/2"	749 mm
D	15 3/4"	400 mm
E	73"	1854 mm
F	36 1/2"	927 mm
G	21 3/4"	552 mm
H	20 3/4"	527 mm
J	51 5/8"	1311 mm

*Note: All framing dimensions calculated for 1/2" dry wall at the fireplace face. If sheathing the chase or finishing with other thickness materials, calculations will need to be made.*

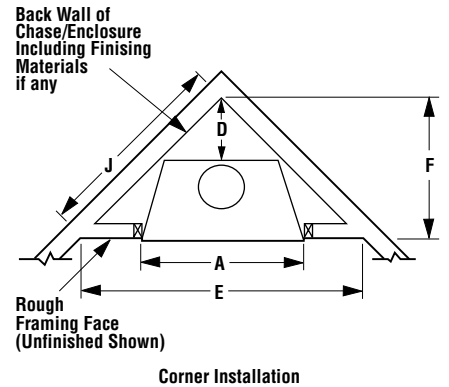


Figure 13

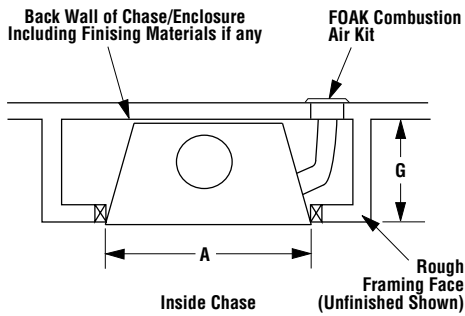


Figure 11

## Framing Dimensions for Ceiling

Flue Type	A	B
FTF8 Vertical	16 1/2" (419 mm)	16 1/2" (419 mm)
FTF8 Offset 30°	16 1/2" (419 mm)	25" (635 mm)

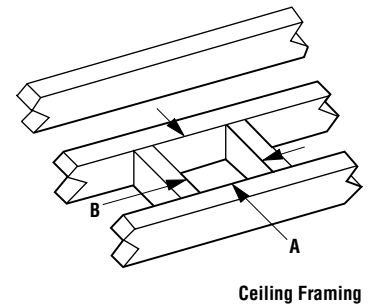


Figure 14

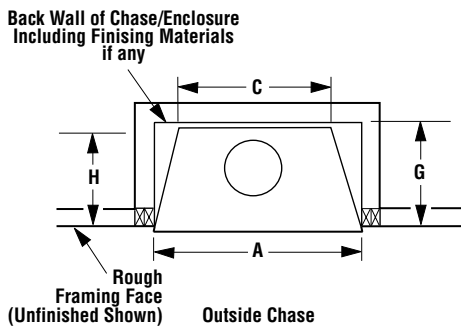


Figure 12

## Framing Dimensions for Roof

Pitch	C	D*
0/12	16 1/2" (419 mm)	16 1/2" (419 mm)
6/12	16 1/2" (419 mm)	19" (483 mm)
12/12	16 1/2" (419 mm)	23 1/2" (597 mm)

\* Perpendicular to roof ridge

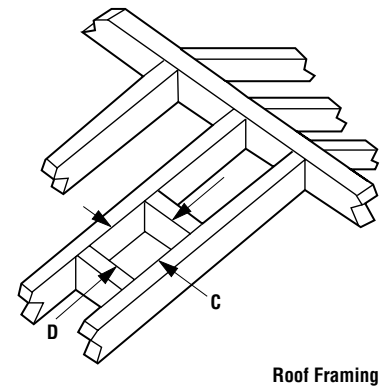
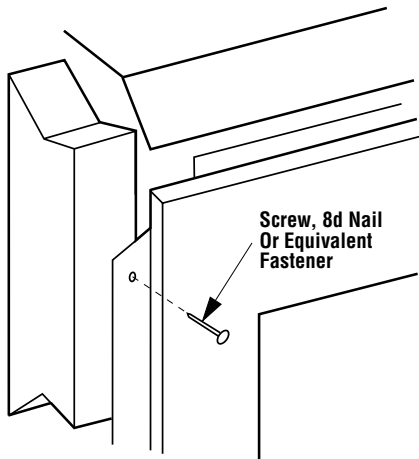


Figure 15

**Step 4.** Fireplace should be secured to side framing members using the full length nailing tabs at the top and bottom of the fireplace front face. Use screws, 8d nails or equivalent fasteners (Figure 16). This manufactured home model is also provided with floor brackets used to secure the fireplace to the floor to prevent shifting in transit.



**Figure 16**

**Note:** The nailing tabs and the area directly behind the nailing tabs are exempt from the clearances described on page 5. Maintain at least 1/2" clearance from the firebox wrapper to the framing at the closest point of contact, directly adjacent to the flange.

### INSTALLING THE CHIMNEY SYSTEM

**Step 1.** Before continuing, check the operation of the damper, as described on page 4, (refer to Figure 2).

**Step 2.** Using standard construction framing techniques, construct opening for chimney route up through the ceiling(s) and roof or through an outside chase.

Framing must maintain adequate minimum air space clearance at all times.

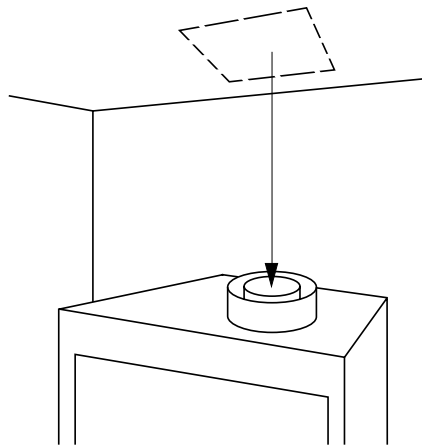
**CAUTION: ALLOW MINIMUM 2" CHIMNEY AIR SPACE TO COMBUSTIBLE FRAMING MEMBERS THROUGHOUT VERTICAL OR OFF-SET CHIMNEY INSTALLATION.**

**A minimum 2" air space must be reserved for all combustible materials extending for any continuous length surrounding the chimney.**

Reference Figures 14 and 15 and charts Framing Dimensions for Ceiling and Roof, which specify minimum ceiling and roof dimensions.

In new construction, to determine chimney center line, use plumb line from roof or ceiling above fireplace to center of flue collar on fireplace.

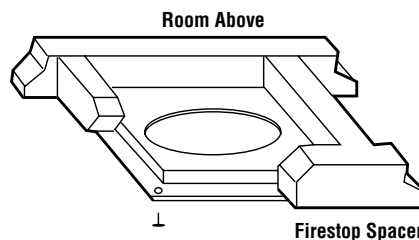
For remodeling, plumb to center of flue collar from ceiling above, drive nail through ceiling from below to mark position, then mark and cut to passage from above ceiling (around nail) (Figure 17). Then plumb from ceiling or roof level directly above hole which has just been completed.



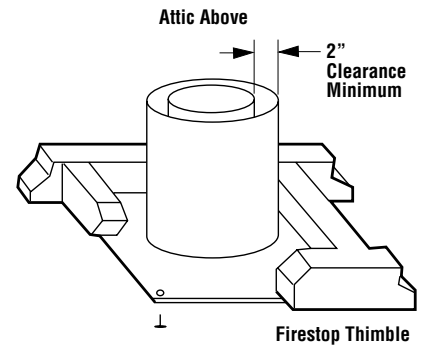
**Figure 17**

**Step 3.** Position appropriate thimble/firestop spacer combination at ceiling and nail temporarily with two (2) 8d nails or equivalent fasteners (see Figures 19, 20 and 21). Use one fastener on opposite sides to hold thimble/firestop spacer combination in position. Nail permanently, using at least two (2) more fasteners, after chimney sections have been assembled through the thimble/firestop spacer combination and after any necessary adjustments have been made. Firestop spacer must be secured by at least four (4) fasteners when completely installed.

**Note:** If there is a room above ceiling level, firestop spacer must be installed on the bottom side of the ceiling. If an attic is above ceiling level, firestop thimble must be installed on the bottom side of ceiling joist (Figures 18 and 19).

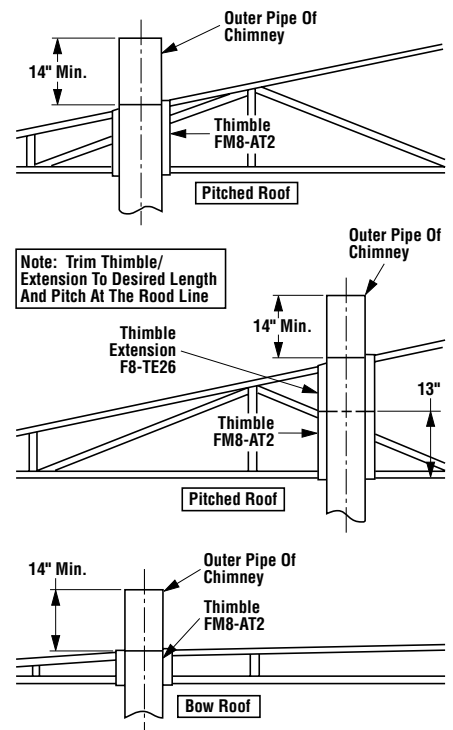


**Figure 18**



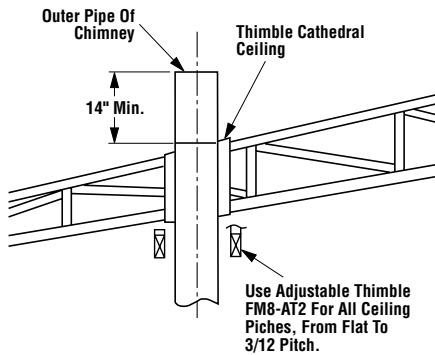
**Figure 19**

Ensure the thimble penetrates the roof opening. The thimble must extend completely through the ceiling or roof cavity to the outermost plane of the roof. Note: Thimble extensions (F8-TE26) are available from your distributor for constructions in which the distance between the outside of the roof and the inside of the ceiling exceeds 13". The thimbles and their extensions provide for zero clearances to combustibles and must be used at the ceiling/roof in manufactured homes (Figures 20 and 21).



**Figure 20**

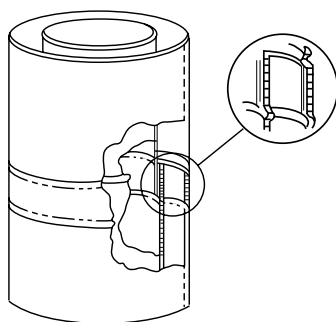
**WARNING: DO NOT ALLOW INSULATING MATERIALS TO BE BLOWN INTO THE SPACE INSIDE THE THIMBLE AND THE CHIMNEY. TO DO SO COULD RESULT IN A FIRE HAZARD.**



**Figure 21**

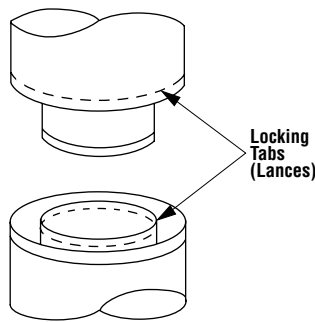
**Step 4. Note:** Chimney sections are constructed with a unique locking tab design, which ensures an immediate, tight assembly between sections. Plan your chimney requirements carefully before assembly as chimney is difficult to disassemble after installation. If disassembled, the tabs might become damaged. Be certain tabs are properly formed to ensure locking tabs engage properly.

The FTF8 chimney system is a two piece chimney, which snap together from the fireplace up. Start with the inner flue section with the lanced end up, snap lock it in to the matching collar on top of the fireplace. At all subsequent joints, the upper flue section fits into the preceding flue section. Each piece snaps together by means of locking tabs (9 locking tabs per joint). Check each piece by pulling up slightly from the top to ensure proper engagement before installing the next section. If the flue has been installed correctly, it will not separate when you test it. Also, the inner flue joint where each section is joined should be tight and flat without gaps (Figure 22).



**Figure 22**

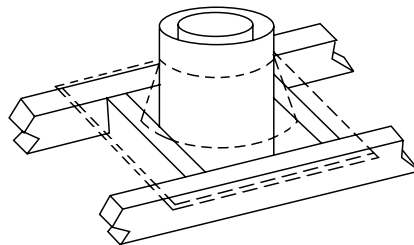
Outer pipe section installs in just the opposite way; the lanced end goes down and each new section goes OVER the outside of the previous section installed (Figure 23).



**Figure 23**

**Note:** Assemble one component of chimney at a time (inner section first, then outer section last) before proceeding with the next complete section.

Continue to assemble the chimney up through framed opening. Assemble just enough to penetrate the roof flashing openings (Figure 24). Maintain 1" minimum air space to insulation and building materials and always check each chimney joint (inner and outer) to ensure proper engagement. Check vertical alignment of chimney so that it projects from the roof in true vertical position.



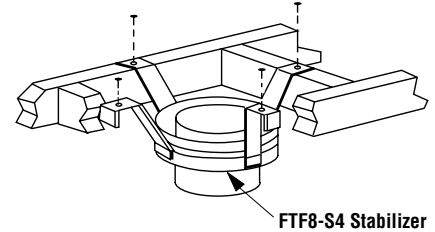
**Figure 24**

FireCraft chimney sections do not need to be screwed together. Additional reinforcement is not necessary except in certain offset conditions (refer to page 13, Figure 35).

**Step 5.** The height of vertical chimney pipe supported only by the fireplace must not exceed 30'. Chimney heights above 30' must be supported by a Model FTF8-S4 stabilizer installed at 30' intervals.

**Note:** The Model FTF8-S4 adds 3" net effective height to the total chimney system.

Install the Model FTF8-S4 stabilizer by fitting inner section down into respective section of proceeding flue pipe and locking outer stabilizer section into place over the outer chimney pipe. Position for proper clearance through framed opening and nail straps securely (under tension in "shear") into place on framing. Use 8d nails. Attach successive lengths of chimney pipe directly to stabilizer using same techniques as described in Step 4 (Figure 25).



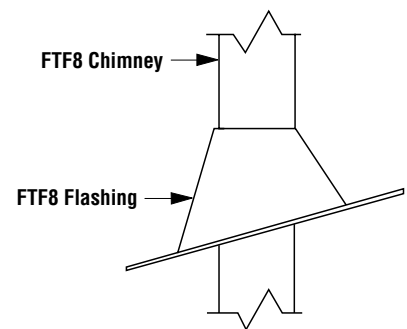
**Figure 25**

**Note:** Do not apply excessive pressure to any subsequent chimney sections following the stabilizer when installing. Ensure each subsequent chimney section is securely attached by testing as noted in Step 4.

**Step 6.** Select the proper FireCraft roof flashing based on pitch of roof. Use chart below for selection:

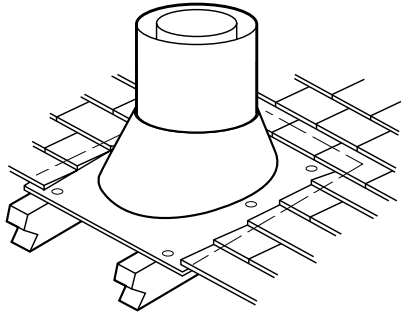
Roof Pitch	Model
Flat to 6/12	F8F6
6/12 to 12/12	F8F12

Next, slide roof flashing over extended chimney section that previously has been installed above the roof opening in Step 4. Slide flashing all the way down until the flashing base rests flat on the roof (Figure 26). Again, check the vertical position of the chimney and the 2" minimum air space to combustibles.



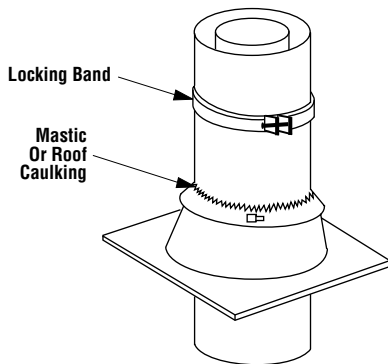
**Figure 26**

**Step 7.** Secure flashing by nailing along the perimeter into roof using 8d nails or equivalent fasteners. If shingled roof, slide upper end and sides of roof flashing under shingles (trim if necessary), seal the top and both sides of the flashing to the roof with roof caulking. Cover fastener heads with roof caulking (Figure 27).



**Figure 27**

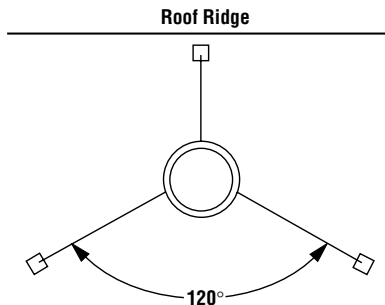
**Step 8.** The standard FireCraft Technologies' FTF8 roof flashing assemblies include a storm collar. Slide the storm collar over outer chimney, rest on flashing spacers and align with top surface of flashing. Insert tab in slot, pull tight and bend tab back over slot. Seal storm collar to outer chimney with roof caulking or mastic around entire circumference of pipe. Also add extra roof caulking to the tab/slot area to seal completely against water penetration (Figure 28). Check all joints very carefully to ensure no water intrusion can take place.



**Figure 28**

**Step 9.** FTF locking bands, Model FLB, may be required if the chimney extends too high above the roof flashing. As a general rule, if the chimney extends more than 6' above the roof flashing, the use of locking bands is advisable to strengthen the chimney assembly. Align the locking band at the chimney joint. Locking bands wrap around pipe joints equally covering the joints of both pipe sections. Use the nut provided and TIGHTEN snugly. Do not over-tighten as this might damage the chimney section (refer to Figure 23).

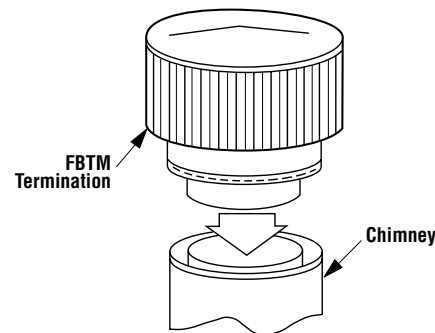
**Note:** If chimney extends more than 8' above roof surface, guy wires are also recommended. Use three (3) guy wires, attach to locking band assembly, extend and secure to roof in a triangular pattern (Figure 29). Guy wires are not supplied by the manufacturer.



**Figure 29**

**Step 10. Using a FBTM Termination:**

1. Hold the FBTM over top of last chimney section (Figure 30).
2. Center inner slip section in inner flue pipe-slip down.



**Figure 30**

**3.** Center outer locking section over outer flue pipe. Push down until locking tabs are firmly engaged.

**4.** Pull up slightly on FBTM to ensure locking joint has firmly engaged.

**Note:** It is recommended that all exterior exposed metal fireplace components; such as terminations, flashings, storm collars and/or flue be painted with a premium quality, high temperature, rust preventative paint designed for metal. This is especially important when installations are made in abnormally adverse or corrosive environments; such as near lakes, oceans or in areas with consistently high humidity conditions. Consult the paint manufacturers instructions for proper preparation and application.

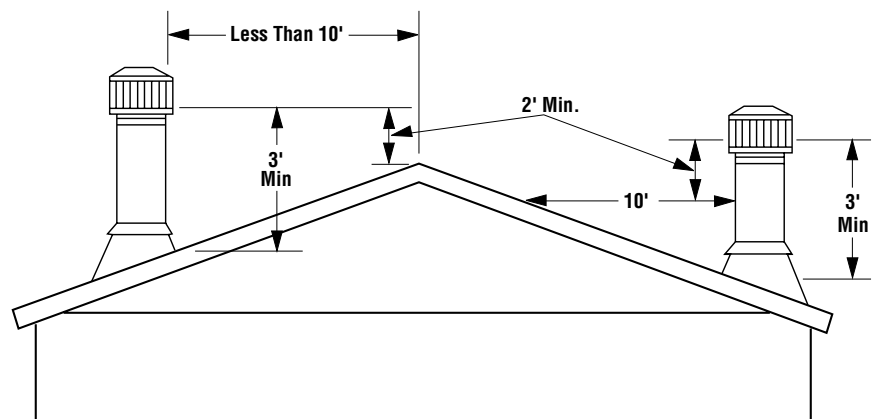
**TEN FOOT RULE SUMMARY**

The minimum chimney height above the roof and/or to adjacent walls and buildings is specified by all major building codes.

If the horizontal distance from the peak of the roof is less than 10', the top of the chimney must be at least 2' above the peak of the roof.

If the horizontal distance from the chimney edge to the peak of the roof is more than 10' a chimney height reference point is established on the roof surface 10' horizontally from the chimney edge. The top of the chimney must be at least 2' above this reference point. In all cases, the chimney cannot be less than 3' above the roof at the edge of the chimney.

The 2' in 10' rule is necessary in the interest of safety but does not ensure smoke-free operation. Trees, buildings, adjoining roof lines, adverse wind conditions, etc., may require a taller chimney should the fireplace not draft properly (Figure 31).



**Figure 31**

## FTF8 CHIMNEY COMPONENT CALCULATIONS

The minimum installed height of the completed fireplace system is 10' 6". The maximum height is 40' 0" when the chimney is exposed.

To determine the number of chimney sections and chimney components required, follow these steps:

1. Determine total vertical height of the fireplace installation. This dimension is the distance from the surface the fireplace sets on to the point where smoke exits from the termination.
2. Determine the number of chimney components required, except chimney sections. This would include thimbles, extensions, roof flashing, etc.
3. The effective heights of the components are:

The Fireplace	=	36 ¼"
FTF8-12	=	10 ¼"
FTF8-18	=	16 ¼"
FTF8-36	=	34 ¼"
FTF8-48	=	46 ¼"
FTF8-BTM Termination	=	6"

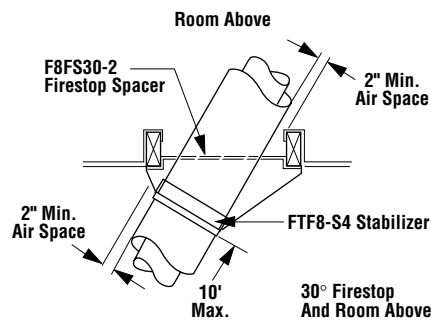
4. Determine amount of chimney height required by subtracting total combined height of all pre-selected components (fireplace and chimney components from total desired height.)

Reference Vertical Elevation Chart and determine the number of chimney sections (quantity and length) required.

## SPECIAL OFFSET INSTRUCTIONS

### Chimney 30° Offset through Floor or Ceiling

It may be necessary to assemble the chimney at 30° when passing through the floor or ceiling area. Use the F8FS30-2 firestop spacer as shown in *Figure 32*. Support the chimney at floor or ceiling penetration with a FTF8 stabilizer if distance of chimney below ceiling is 10' or more. Maintain 2" minimum air space to combustibles from chimney sections.



**Figure 32**

To clear any overhead obstructions, you may offset your chimney system using FireCraft 30° offset and return elbows. Use two elbows, an offset elbow to initiate the offset and a return elbow to terminate it. A 30° offset elbow, angling in any direction, may be the first component used off the top of the fireplace flue collar.

The offset and return elbows may be attached together, or a section or sections of chimney may be used between, but do not exceed 20' in total length between elbows. If sections of pipe exceed 10' between elbows, a chimney stabilizer must be used at the midpoint (see *Figure 33*). The stabilizer support straps must be attached under tension (in shear) to structural framing members above. When two sets of elbows are used, the maximum combined length of chimney used between elbows cannot exceed 20' (see *Figure 34*). **Example:** If  $C_1 = 10'$  then  $C_2$  cannot exceed 10'.

If an offset exceeds 6' in length, each chimney joint beyond the first 6' of offset to the return elbow, must be secured by a No. 8 x ½" sheet metal screw located at the underside of the joint (see *Figure 36*).

A ⅛" diameter hole must be drilled in the chimney joint using a ⅛" diameter drill. Hole should be drilled in center of joint overlap (see *Figure 36*). Be sure to drill only through the outer chimney casting. Do not puncture the inner flue.

Maximum offset of chimney system is 30°. Two offsets must not be assembled to form a 60° offset. However, two sets of offset and return elbows may be used on a single flue system, provided the total height of the system exceeds 25'.

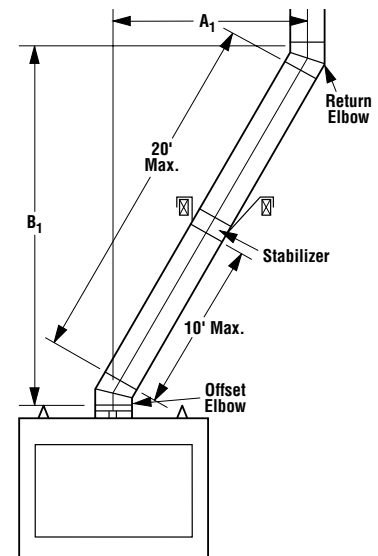
Return elbow support straps must be securely attached under tension (in shear) to structural framing members above. Do not substitute a FTF8-30 offset elbow in place of a FTF8-E30 return elbow.

## OFFSET CALCULATIONS

**Step 1.** Use Offset Chart to determine amount of horizontal offset (A) and height (B) for various chimney section assemblies.

**Step 2.** Use "Height of Chimney Only" column in The Vertical Elevation Chart to determine combinations of chimney used above return elbow to achieve desired heights. Reference Components Effective Height Chart in vertical elevation chart section.

**Step 3.** Use Elevation Chart as job estimator only. Add necessary firestop spacers and stabilizers as required. Firestop spacers must be used as shown in *Figure 19* and stabilizers as shown in *Figure 26*.

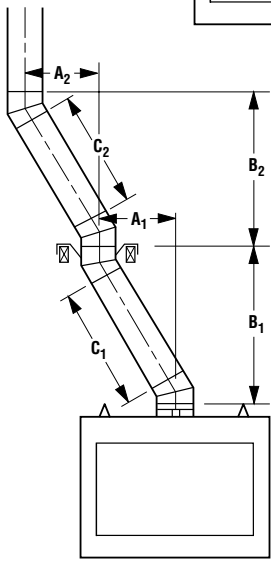
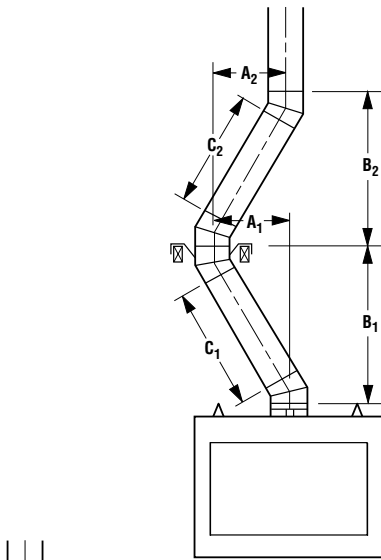


**Figure 33**

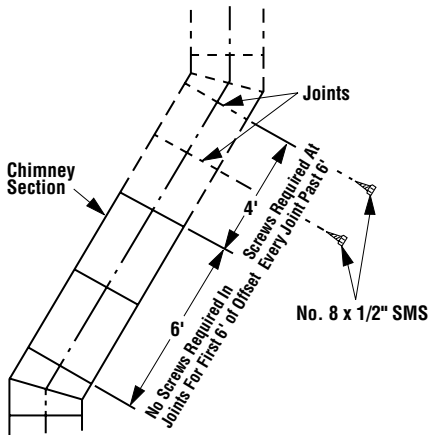
## FTF8 VERTICAL ELEVATION CHART

Height Of Chimney Only		Number Of FTF8 Chimney Lengths				Height Of Chimney Only		Height Of Chimney Only		Number Of FTF8 Chimney Lengths				Height Of Chimney Only	
Inches	Feet/Inches	12"	18"	36"	48"	MM	M	Inches	Feet/Inches	12"	18"	36"	48"	MM	M
11	0 11	1	0	0	0	279	0.28	252	21 0	2	0	0	5	6401	6.40
17	1 5	0	1	0	0	432	0.43	258	21 6	1	1	0	5	6553	6.55
21 ¼	1 9 ¼	2	0	0	0	540	0.54	266	22 2	0	0	1	5	6756	6.76
27 ¼	2 3 ¼	1	1	0	0	692	0.69	276	23 0	1	0	1	5	7010	7.01
35	2 11	0	0	1	0	889	0.89	278	23 2	0	0	0	6	7061	7.06
47	3 11	0	0	0	1	1194	1.19	282	23 6	0	1	1	5	7163	7.16
51 ¼	4 3 ¼	0	1	1	0	1302	1.30	288	24 0	1	0	0	6	7315	7.32
57 ¼	4 9 ¼	1	0	0	1	1454	1.45	294 ¾	24 6 ¾	0	1	0	6	7487	7.49
63 ¼	5 3 ¼	0	1	0	1	1607	1.61	298 ¼	24 10 ¼	2	0	0	6	7576	7.58
67 ¼	5 7 ¼	2	0	0	1	1708	1.71	304 ¼	25 4 ¼	1	1	0	6	7728	7.73
73 ¼	6 1 ¼	1	1	0	1	1861	1.86	312	26 0	0	0	1	6	7925	7.93
81 ¼	6 9 ¼	0	0	1	1	2064	2.06	322 ¼	26 10 ¼	1	0	1	6	8185	8.19
93 ¼	7 9 ¼	0	0	0	2	2369	2.37	324	27 0	0	0	0	7	8230	8.23
97 ¼	8 1 ¼	0	1	1	1	2470	2.47	328 ¼	27 4 ¼	0	1	1	6	8338	8.34
102 ½	8 6 ½	1	0	0	2	2604	2.60	334 ¼	27 10 ¼	1	0	1	7	8490	8.49
109 ¼	9 1 ¼	0	1	0	2	2775	2.78	340 ¼	28 4 ¼	0	1	0	7	8642	8.64
113 ½	9 5 ½	2	0	0	2	2883	2.88	344 ½	28 8 ½	2	0	0	7	8750	8.75
119 ½	9 11 ½	1	1	0	2	3035	3.04	350 ½	29 2 ½	1	1	0	7	8903	8.90
127 ¼	10 7 ¼	0	0	1	2	3232	3.23	358 ¼	29 10 ¼	0	0	1	7	9100	9.10
137 ½	11 5 ½	1	0	1	2	3493	3.49	368 ½	30 8 ½	1	0	1	7	9360	9.36
139 ¼	11 7 ¼	0	0	0	3	3537	3.54	370 ¼	30 10 ¼	0	0	0	8	9404	9.40
143 ½	11 11 ½	0	1	1	2	3645	3.65	374 ½	31 2 ½	0	1	1	7	9512	9.51
149 ½	12 5 ½	1	0	0	3	3797	3.80	380 ½	31 8 ½	1	0	0	8	9665	9.67
155 ½	12 11 ½	0	1	0	3	3950	3.95	386 ½	32 2 ½	0	1	0	8	9817	9.82
159 ¾	13 3 ¾	2	0	0	3	4058	4.06	390 ¾	32 6 ¾	2	0	0	8	9925	9.93
165 ¾	13 9 ¾	1	1	0	3	4210	4.21	396 ¾	33 0 ¾	1	1	0	8	10077	10.08
173 ½	14 5 ½	0	0	1	3	4407	4.41	404 ½	33 8 ½	0	0	1	8	10274	10.27
183 ¾	15 3 ¾	1	0	1	3	4667	4.67	414 ¾	34 6 ¾	1	0	1	8	10535	10.53
185 ½	15 5 ½	0	0	0	4	4712	4.71	416 ½	34 8 ½	0	0	0	9	10579	10.58
189 ¾	15 9 ¾	0	1	1	3	4820	4.82	420 ¾	35 0 ¾	0	1	1	8	10687	10.69
195 ¾	16 3 ¾	1	0	0	4	4972	4.97	426 ¾	35 6 ¾	1	0	0	9	10839	10.84
201 ¾	16 9 ¾	0	1	0	4	5124	5.12	432 ¾	36 0 ¾	0	1	0	9	10992	10.99
206	17 2	2	0	0	4	5232	5.23	437	36 5	2	0	0	9	11100	11.10
212	17 8	1	1	0	4	5385	5.39	443	36 11	1	1	0	9	11252	11.25
219 ¾	18 3 ¾	0	0	1	4	5582	5.58	450 ¾	37 6 ¾	0	0	1	9	11449	11.45
230	19 2	1	0	1	4	5842	5.84	461	38 5	1	0	1	9	11709	11.71
231 ¾	19 3 ¾	0	0	0	5	5886	5.89	462 ¾	38 6 ¾	0	0	0	10	11754	11.75
236	19 8	0	1	1	4	5994	5.99	466 ¾	38 10 ¾	0	1	1	9	11855	11.86
242	20 2	1	0	0	5	6147	6.15	472 ¾	39 4 ¾	1	0	0	10	12008	12.01
248	20 8	0	1	0	5	6299	6.30	478 ¾	39 10 ¾	0	1	0	10	12160	12.16

## FTF8 OFFSET ELEVATION CHART



**Figure 34**



**Figure 35**

A Offset (Inches)	B Height (Inches)	FTF8-ES30 Offset/Return Elbow Set	FTF8-S4 Stabilizer	Number of FTF8 Chimney Sections				A Offset (mm)	B Height (mm)
				12"	18"	36"	48"		
4	15 3/4	1	0	0	0	0	0	102	400
9	24 1/2	1	0	1	0	0	0	229	622
12	29 3/4	1	0	0	1	0	0	305	756
14 1/4	33 1/2	1	0	2	0	0	0	362	851
17 1/4	38 1/2	1	0	1	1	0	0	438	978
20 1/4	43 3/4	1	0	0	2	0	0	514	1111
21	45 1/4	1	0	0	0	1	0	533	1149
22 1/4	47 1/2	1	0	2	1	0	0	565	1207
25 1/4	52 1/2	1	0	1	2	0	0	641	1334
26 1/4	54 1/4	1	0	1	0	1	0	667	1378
27	55 3/4	1	0	0	0	0	1	686	1416
28 1/4	57 3/4	1	0	0	3	0	0	718	1467
29 1/4	59 1/4	1	0	0	1	1	0	743	1505
31 1/4	63	1	0	2	0	1	0	794	1600
32 1/4	64 1/2	1	0	1	0	0	1	819	1638
34 1/4	68 1/4	1	0	1	1	1	0	870	1734
35 1/4	69 3/4	1	0	0	1	0	1	895	1772
37 1/4	73 1/4	1	0	0	2	1	0	946	1861
38 1/4	75	1	0	0	0	2	0	972	1905
39 1/4	77	1	0	2	1	1	0	997	1956
41 1/2	80 1/2	1	0	1	4	0	0	1054	2045
43 1/4	83 3/4	1	0	1	0	2	0	1099	2127
44 1/4	85 1/4	1	0	0	0	1	1	1124	2165
45 1/4	87 1/2	1	0	0	3	1	0	1149	2223
46 1/4	89	1	0	0	1	2	0	1175	2261
48 1/4	91 1/2	1	0	2	0	2	0	1226	2324
49 1/4	94 1/4	1	0	1	0	1	1	1251	2394
50 1/4	95 3/4	1	0	0	0	0	2	1276	2432
51 1/4	97 3/4	1	0	1	1	2	0	1302	2483
54 1/4	103	1	0	0	2	2	0	1378	2616
55 1/4	104 1/2	1	0	1	0	0	2	1403	2654
56 1/2	106 1/2	1	0	2	1	2	0	1435	2705
58 1/4	109 3/4	1	0	0	1	0	2	1480	2788
62 1/2	116 3/4	1	1	1	0	3	0	1588	2965
65 1/2	122	1	1	0	1	3	0	1664	3099
67 3/4	125 1/2	1	1	2	0	3	0	1721	3188
69 1/2	128 3/4	1	1	0	0	1	2	1765	3270
70 3/4	130 3/4	1	1	1	1	3	0	1797	3321
73 3/4	136	1	1	0	2	3	0	1873	3454
75 1/2	139	1	1	0	0	0	3	1918	3531
79 3/4	146 1/4	1	1	1	0	4	0	2026	3715
80 3/4	148	1	1	1	0	0	3	2051	3759
82 3/4	151 1/2	1	1	0	1	4	0	2102	3848
83 1/2	153	1	1	0	1	0	3	2121	3886

NOTE: DIAGRAMS & ILLUSTRATIONS NOT TO SCALE.

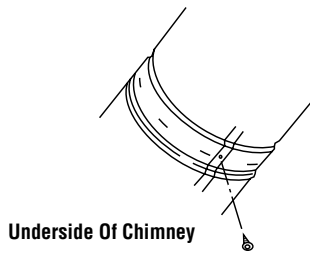
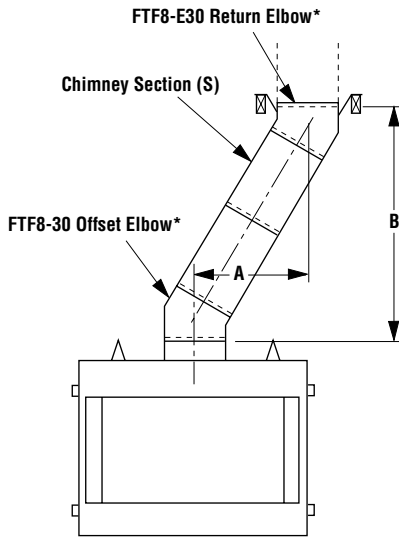


Figure 36



\*Part of Offset/Return Package Model FTF8-ES30

Figure 37

## INSTALLING OFFSETS

First, review the Offset Elevation Chart and Figure 37 for reference.

**Step 1.** Determine the offset distance where chimney is to pass through the first ceiling-dimension "A." To find this point on your ceiling, first determine the center point for a vertical chimney following the instructions for vertical installation.

Measure height to the ceiling from the top of fireplace-dimension "B." Use the appropriate Offset Elevation Chart to find dimension "A." Mark point where you will drive your nail to show the center point for your offset ceiling cut.

**Step 2.** Proceed by using the Straight Up Installation Instructions for cutting and framing installation ceiling and roof openings.

**Note:** See Framing and Dimension Chart for the sizes of the ceiling and roof openings. The size of the roof opening varies with the degree of pitch of the roof.

## Offset Elbow Assembly

Offset elbows install the same as chimney sections. First, snap the inner section INTO the preceding inner section of flue. Check connection by pulling up slightly to ensure a tight fit. Next, the outer sections snap lock OVER the preceding outer section of chimney. Again, check outer section by pulling up slightly to ensure proper connection is made.

## Return Elbow Assembly

Return elbows install the same way as round terminations and stabilizers:

**Step 1.** Hold return elbow over top of last chimney section.

**Step 2.** Center inner slip section into inner flue pipe-slip down.

**Step 3.** Center outer-locking section over outer chimney pipe. Push down until locking joint has firmly engaged.

**Step 4.** Pull up slightly on return elbow to ensure locking joint has firmly engaged.

**Step 5.** Secure support straps to framing members by nailing under tension in sheer (Figure 38).

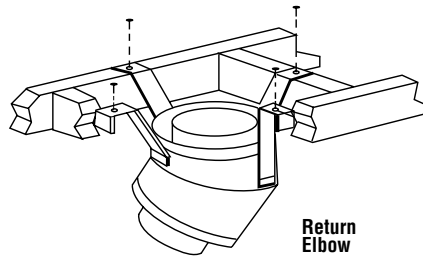


Figure 38

**Note:** The return elbow assembly performs the same function as a stabilizer. Consider this when determining the need for a stabilizer.

**Note:** Do not apply excessive pressure to any subsequent chimney section following return elbow assembly when installing. Ensure that each subsequent chimney section is securely attached by testing as noted above.

## OPTIONAL EQUIPMENT CONSIDERATIONS

### Blower Kit

A Blower Kit model FBK-200 is available for use with these models. The Blower Kit is installed standard on the fireplace.

**Note:** These fireplace models require a wall switch for fan operation. Refer to the installation instructions included with the Blower Kit for installation details.

**THE FIREPLACE MUST BE WIRED TO THE HOUSE ELECTRICAL SYSTEM AT THE TIME OF INSTALLATION IN ORDER FOR THE FANS TO OPERATE, (SEE FIGURES 39 AND 40).**

POWER TO THE FIREPLACE  
The Optional Blower Kit  
Operates on 115 volt 60 Hz  
150 watts AC

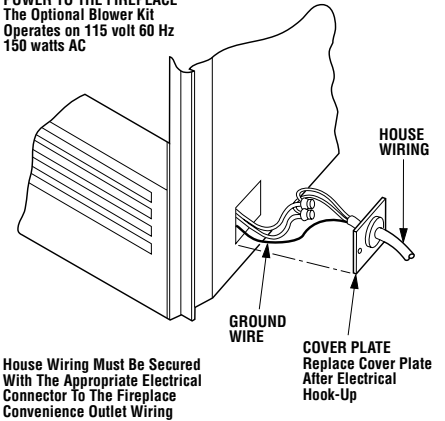


Figure 39

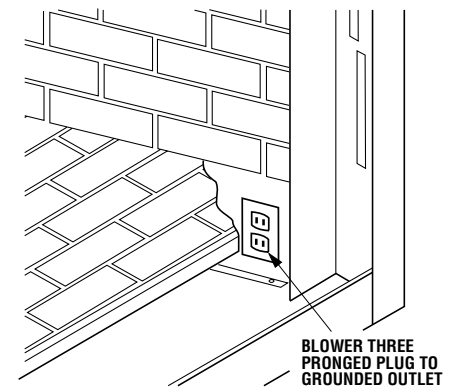


Figure 40

**Note:** The utilization of fans will increase the air flow around the firebox. However, only a minimal increase in heat output should be anticipated.

**THIS FIREPLACE IS NOT INTENDED TO BE USED AS A SUBSTITUTE FOR A FURNACE TO HEAT AN ENTIRE HOME. USE FOR SUPPLEMENTARY HEATING ONLY.**

The FBK-200 Blower Kit is design certified by Warnock Hersey for use with these appliances.

Always check local building codes. Installation of the FBK-200 Blower Kit must comply with local regulations as well as the National Electric Code.

### Combustion Air Kits

These appliances are equipped with an outside (make-up) air door and integral actuator arm. The appliance must be installed with an outside air vent system (Figure 41). These kits come complete with detailed installation instructions and all components necessary in completing a combustion air vent system.

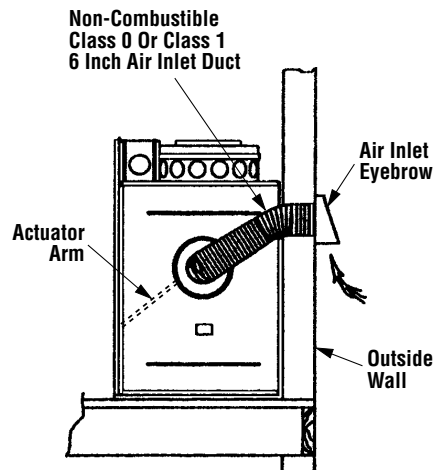


Figure 41

After completing the installation of the combustion air vent system the actuator arm must be put in service and tested to ensure proper operation before completing any enclosure around the firebox. Failure to do so may result in extensive and costly rework.

Locate the actuator arm along the right side of the appliance firebox opening and refer to Figure 42.

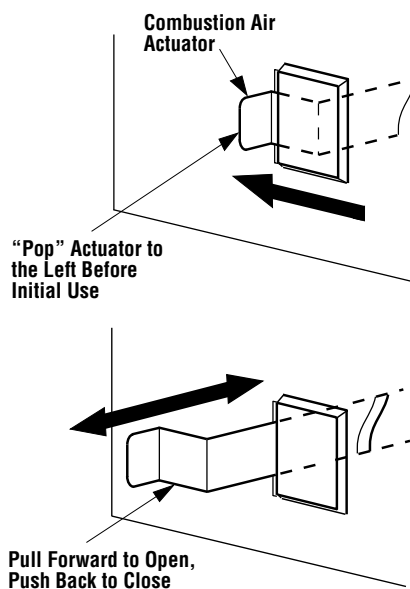


Figure 42

To operate, push the end of the actuator to the left as shown in Figure 42, until it "pops" free of its "locked" position. Pull the actuator forward to open the combustion air door, and push it back to close. To "lock" the combustion air door closed, ensure the actuator is pushed all the way back then push the end of the actuator to the right until the step in the actuator moves behind the appliance front face within the slotted opening.

Operate the actuator through several cycles including the "lock" position. Ensuring proper operation and freedom of movement. Return the actuator arm to the locked position.

### Gas Line Connection

Install only a 1/2" black iron pipe through fireplace wall for connection to a decorative gas appliance inside the firebox. Outside, the iron pipe connects to a gas shut-off valve recessed flush into the wall or floor. The valve should be controlled by a removable valve key for safety.

Always plumb gas line installation per local codes. Check all connections with soap suds; leaks will bubble. Never test any gas line connection with a match or open flame.

This provision is intended for connection to a decorative gas appliance incorporating an automatic shut-off device and complying with the Standard for Decorative Gas Appliances for installation in vented fireplaces, ANSI Z21.60 (1991) or American Gas Association draft requirements for Gas-Fired Log Lighters for Wood Burning Fireplaces, Draft No. 4 dated August, 1993. Install in accordance with the National Fuel Gas Code, ANSI Z223.1. This complies with the revised U.L. 127 standard.

**WARNING: THIS FIREPLACE HAS NOT BEEN TESTED WITH AN UNVENTED GAS LOG SET. TO REDUCE RISK OF FIRE OR INJURY, DO NOT INSTALL AN UNVENTED GAS LOG SET INTO THIS FIREPLACE.**

**CAUTION: WHEN USING THE DECORATIVE GAS APPLIANCE, THE FIREPLACE DAMPER MUST BE SET IN THE FULLY OPEN POSITION.**

**CAUTION: PLUMBING CONNECTIONS SHOULD ONLY BE PERFORMED BY A QUALIFIED, LICENSED PLUMBER. MAIN GAS SUPPLY MUST BE OFF WHEN PLUMBING GAS LINE TO FIREPLACE OR PERFORMING SERVICE.**

If you're installing a gas line, connect it before the fireplace is framed and enclosed in the finished wall. The gas knockout is determined by the indentation located at the bottom and slightly off center in the side refractories. **THE KNOCKOUT IS ALWAYS REMOVED FROM INSIDE THE FIREPLACE. DO NOT REMOVE THE KNOCKOUT UNLESS YOU ARE INSTALLING A GAS LINE.** If removal is attempted from the outer wrapper, side refractory damage may occur. With a medium-sized hammer, lightly tap the surface of the indentation. The refractory material is very thin in this area and is easily removed. Once a small hole has been made, continue tapping until you have reached sufficient diameter for the gas line to fit through. The entire knockout does not have to be removed. Remove insulation in the gas line channel.

**IMPORTANT: REPACK INSULATION MATERIAL IN SQUARE HOLE AROUND GAS LINE, INTERIOR AND EXTERIOR OF FIREPLACE, TO SEAL.**

## Glass Doors

Glass doors have been installed on these fireplaces as standard equipment. Shipping and transit may have moved them out of alignment.

The doors are properly adjusted when the top door trim is in a straight, level line and the gap between the doors is even at the top and bottom. If adjustments are required, grasp the door handle and loosen the lower door pivot pin using a  $\frac{3}{8}$ " open end wrench\*. Slide the door panel on the hinge pin until the gap between the upper door trim and upper frame is even. Retighten the lower door pivot pin\*. Repeat this procedure for the opposite door if needed (Figure 43).

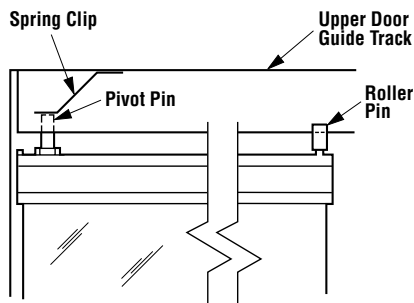


Figure 43

\*Note: Upper door pivot pins can also be loosened for adjustment purposes; however, it is easier to loosen lower pins.

## COLD CLIMATE INSULATION

If you live in a cold climate, it is especially important to seal all cracks around the fireplace opening with noncombustible material and wherever cold air could enter the room. Surrounding materials must be caulked where it meets the black metal facing of the fireplace to avoid cold air intrusion. Use noncombustible caulking material only on fireplace facing to seal. Also, the outside air inlet duct should be wrapped with noncombustible insulation to minimize the formation of condensation. Do not place insulation materials on top of fireplace or against chimney sections.

Note: A 2" air space must be preserved for all combustible materials extending for any continuous length adjacent to the chimney.

It is especially important to insulate between the studs of an outside chase cavity and under the floor if the floor is above ground level. Do not place insulation directly against the fireplace or chimney system.

## FIREPLACE FINISHES

### Mantels and Trim

It is sometimes best to frame your fireplace after it is positioned and the chimney is installed. Frame enclosure for chimney and fireplace with 2 x 4's (or heavier) lumber.

Note: The header may rest on the two (2) metal top spacers on top of the unit but the header must not be notched to fit around the spacers.

These fireplaces may sit directly on a combustible surface. A 2" air space is required between combustible framing and the chimney. A 1" air space is required between combustible framing and fireplace outer wrapper. Combustible mantels and trim may be installed 12" above the fireplace opening as per NFPA 211, Section 7-2.3.3. and Figure 44. If a mantel is of a noncombustible material, it is exempt from these requirements as long as it does not interfere with the installation or operation of glass doors.

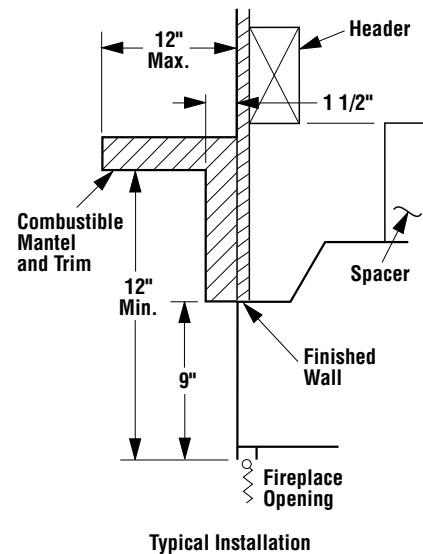


Figure 44

### Hearth Extensions and Wall Shields

A hearth extension must be installed with all fireplaces. It is to protect the combustible floor in front of the fireplace from both radiant heat and sparks.

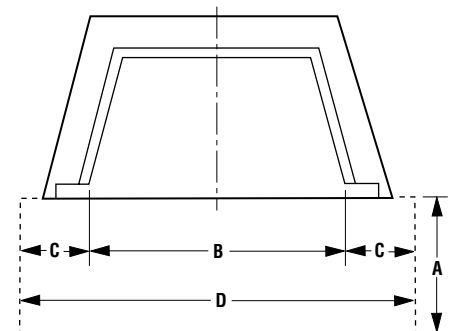
The hearth extension must extend 8" beyond both sides of the fireplace opening and 16" beyond the front (Figure 45). Use a hearth extension constructed of a durable noncombustible material having an equal or greater insulating value of  $k = .84\text{BTU/In Hr Ft}^2\text{ }^\circ\text{F}$  or a thermal resistance that equals or exceeds  $r = 1.19\text{ In Ft}^2\text{ Hr }^\circ\text{F/ BTU}$ . With these values, determine the minimum thickness/material required using the formula and the Table on page 17.

Note: Any noncombustible material whose  $k$  value is less than .84 or whose  $r$  value is more than 1.19 is acceptable.

If the fireplace is installed on a combustible floor, use the metal safety strips (provided) on the floor extending half under the fireplace and half under the hearth extension (refer to Figures 6 and 7).

A wall shield is required where a continuous perpendicular side wall is within 12" of the fireplace opening, (see Figure 46). Use a 24" W x 30" H wall shield constructed of millboard or a durable, noncombustible material having an equal or greater insulating value than  $K = .54\text{BTU/IN FT}^2\text{ HR }^\circ\text{F}$ . At no time may a perpendicular side wall be closer than 7".

If fireplace is installed diagonally across a 90° corner; no wall shields are required.



Hearth Extension Dimensions

A	16"
B	33"
C	8"
D	49"

Figure 45

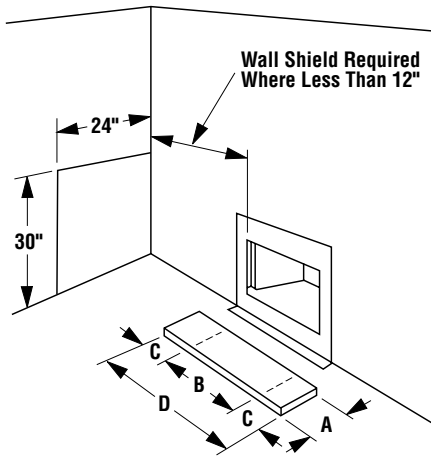


Figure 46

### Methods of Determining Hearth Extension and Wall Shield Equivalents

To determine the thickness required for any material when either the k or r values are known:

- $T_M$  = Thickness of material in inches
- $k_M$  = K value of desired material
- $r_M$  = R value of desired material
- $T_L$  = Minimum listed thickness

**Example:** Micore CV230 is to be used for the hearth extension fireplace. How thick must this material be?

Using the k formula:

$$\text{Desired Required Thickness} = \frac{k \text{ value of desired material (per inch)}}{k \text{ value of listed material (per inch)}} \times \text{Min. thickness of Listed Material}$$

$$T_M (\text{inches}) = \frac{k_M}{0.84} \times T_L$$

$$T_M (\text{inches}) = \frac{0.43^*}{0.84} \times \frac{5}{8}''$$

Answer using  $k = 0.51 \times \frac{5}{8}'' = 0.32 = \frac{3}{8}''$   
 $\frac{3}{8}''$  thickness Micore will be required.

Using the r formula:

$$\text{Desired Required Thickness} = \frac{r \text{ value of listed material (per inch)}}{r \text{ value of desired material (per inch)}} \times \text{Min. thickness of Listed Material}$$

$$T_M (\text{inches}) = \frac{1.19}{r_M} \times T_L$$

$$T_M (\text{inches}) = \frac{1.19}{2.33^*} \times \frac{5}{8}''$$

Answer using  $r = 0.51 \times \frac{5}{8}'' = 0.32 = \frac{3}{8}''$   
 $\frac{3}{8}''$  thickness Micore will be required.

At times it is important to know what combination of materials are acceptable for use as hearth extensions. The "R values" are used to determine acceptable combinations of materials because "R values" are additive where r and k values are not.

$$"R \text{ value}" = \frac{1}{k} = r \times \text{thickness of material used}$$

### Alternative Hearth Extension and Wall Shield Materials

Listed Material	Values		Min. Thick
	k	r	$T_L$
Millboard	.84	1.19	$\frac{5}{8}''$
Alternative Materials	Values		Min. Thick
	k	r	$T_M$
Wonderboard	1.92	0.52	1 $\frac{1}{2}''$
Common brick	5.00	0.20	3 $\frac{3}{4}''$
Cement mortar	5.00	0.20	3 $\frac{3}{4}''$
Ceramic tile	12.5	0.08	9 $\frac{1}{4}''$
Marble	11.0	0.09	8 $\frac{1}{4}''$
Micore CV230 (U.S. Gypsum)	0.43	2.33	$\frac{3}{8}''$
Ceraform 126 (Johns-Manville)	0.27	3.70	$\frac{1}{4}''$

**Example:** Given that the required "R value" for a suitable hearth extension used must be equal to or greater than:

$$"R" = r \times T_L = 1.19 \times \frac{5}{8}'' = 0.74.$$

If it is desired to elevate a marble hearth extension to a level of 5" or more above the floor surface. What combination of noncombustible materials can be used to accomplish this?

If common brick is used so that the 3  $\frac{1}{2}''$  dimension is the height, "R" for the common brick becomes:

$$"R" = r \times T_M = 0.20 \times 3 \frac{1}{2}'' = 0.70$$

Using  $\frac{1}{2}''$  of mortar to set the brick, "R" for the mortar is calculated as follows:

$$"R" = r \times T_M = 0.20 \times \frac{1}{2}'' = 0.10$$

\*value taken from chart

A  $\frac{3}{4}''$  marble slab set in  $\frac{1}{2}''$  mortar covers the brick, "R" for the marble and mortar becomes:

$$"R" = r \times T_M = 0.09 \times \frac{3}{4}'' = .068$$

$$"R" = r \times T_M = 0.20 \times \frac{1}{2}'' = .10$$

The sum of all "R values" is:

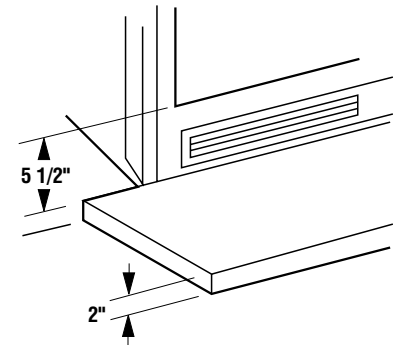
$$.70 + .10 + .068 + .10 = .968$$

This would be an acceptable combination of material for the hearth extension since the total calculated "R value" of the materials used exceeds the required "R value" of 0.74.

**WARNING: THE CRACK BETWEEN THE FIREPLACE AND THE HEARTH EXTENSION MUST BE SEALED WITH A NON-COMBUSTIBLE MATERIAL.**

**WARNING: WHEN INSTALLING THE HEARTH EXTENSION BE CAREFUL NOT TO BLOCK THE HEAT-CIRCULATING AIR INLET GRILL ON CIRCULATING MODELS.**

**WARNING: WHEN INSTALLING HEARTH EXTENSION IN FRONT OF A CIRCULATING FIREPLACE MODEL, THE FIREPLACE MUST BE RAISED IF HEIGHT OF HEARTH EXTENSION EXCEEDS 2" ABOVE BOTTOM OF FIREPLACE (FIGURE 47).**



Max. Thickness Of Hearth Extension When Circulating Models Are On The Floor

Figure 47

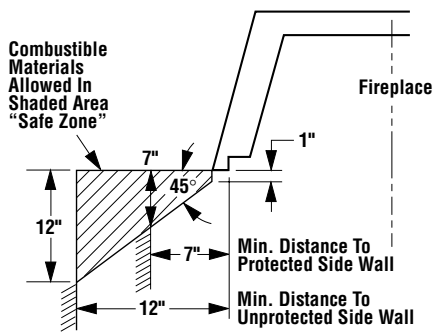
Secure the hearth extension to the floor to prevent possible shifting.

## FINISH TO YOUR TASTE

There are a wide variety of “finished looks” for these fireplaces, from formal wall decor with elaborate mantels to rustic wood paneling or warm brick facings.

Only noncombustible materials like stone, tile, brick, etc., may overlap the black front facing. Do not extend these materials beyond the black facing and into the firebox area. Be sure not to interfere with the installation and operation of glass doors or block the upper or lower grilles. Seal all joints between the black facing and wall surrounds to prevent air intrusion. Use non-combustible caulking material only to seal the black metal facing to the surround material on the finished wall.

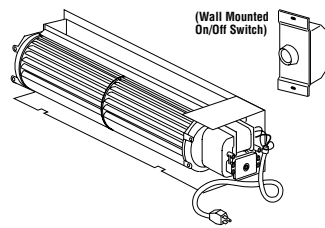
Combustible materials may project beyond the sides of the fireplace opening as long as they are kept within the shaded areas illustrated in *Figure 48*.



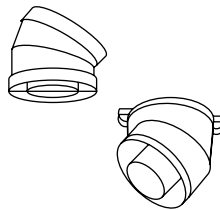
*Figure 48*

## INSTALLATION COMPONENTS

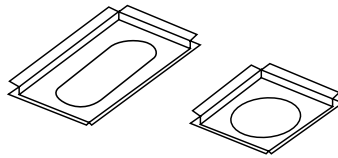
The following items are available for use in the installation of this appliance.



**Forced Air Blower Kit -Variable Speed**      **80L85**      **FBK-200**



**Offset/ Return Package (30°)**      **63L22**      **FTF8-ES30**



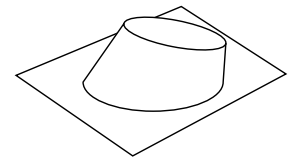
**Firestop Spacer (30°)**      **63L32**      **F8FS30-2**  
**Firestop Spacer (Flat)**      **63L31**      **F8FS-2**

**Shipping Weight**      **175 lbs.**



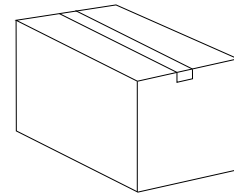
<b>63L10</b>	<b>FTF8-12</b>
<b>63L13</b>	<b>FTF8-18</b>
<b>63L14</b>	<b>FTF8-36</b>
<b>63L15</b>	<b>FTF8-48</b>

**Chimney Section**



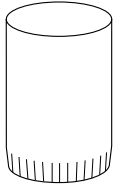
<b>63L38</b>	<b>F8F6</b>
<b>63L39</b>	<b>F8F12</b>

**Flashing**

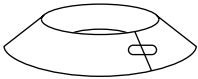


**Adjustable Chimney Pipe Kits**      **H0324**      **FM8-PK2**

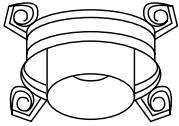
# INSTALLATION COMPONENTS



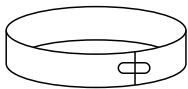
**Thimble Extension 2"**      **19M52**      **F8-TE26-2**



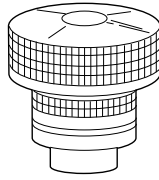
**Storm Collar**      **63L59**      **FSC**



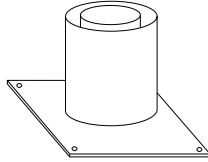
**Stabilizer**      **63L25**      **FTF8-S4**



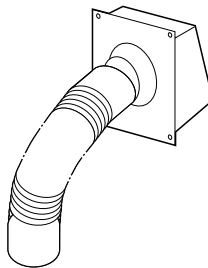
**Locking Band**      **63L60**      **FLB**



**Round Termination**      **63L42**      **FTF8-CTD**



**Adjustable Firestop/Thimble**      **H0326**      **FM8-AT2**



**Cold Climate Kit**      **63L62**      **FTF8-CCK2-LD**

NOTE: DIAGRAMS & ILLUSTRATIONS NOT TO SCALE.

---

The manufacturer reserves the right to make changes at any time, without notice, in design, materials, specifications, prices and also to discontinue colors, styles and products. Consult your local distributor for fireplace code information.

Printed in U.S.A. © 2001 by LHP  
**P/N 800,018M REV. D 04/2002**

**LHP**  
**1110 West Taft Avenue**  
**Orange, CA 92865**