



INSTALLATION INSTRUCTIONS DESIGNER DIRECT VENT MULTI-OPEN

RETAIN THESE INSTRUCTIONS
FOR FUTURE REFERENCE

VENTED GAS FIREPLACE HEATERS - DIRECT VENT MODELS
P/N 800,021M REV. A 01/2002

This appliance may be installed as an OEM installation in a manufactured home (USA only) or mobile home and must be installed in accordance with the manufacturer's instructions and the manufactured home construction and safety standard, *Title 24 CPF, Part 3280* or Standard for Installation in Mobile Homes, *CAN/CSA Z240 MH*. This appliance is only for use with the type(s) of gas indicated on the rating plate. A conversion kit is supplied with the appliance.

MODELS

*Millivolt
Models*
DMSTNM-2
DMPFNM-2

WARNING: IF THE INFORMATION IN THIS MANUAL IS NOT FOLLOWED EXACTLY, A FIRE OR EXPLOSION MAY RESULT CAUSING PROPERTY DAMAGE, PERSONAL INJURY OR LOSS OF LIFE.

AVERTISSEMENT: ASSUREZ-VOUS DE BIEN SUIVRE LES INSTRUCTIONS DONNÉ DANS CETTE NOTICE POUR RÉDUIRE AU MINIMUM LE RISQUE D'INCENDIE OU POUR ÉVITER TOUT DOMMAGE MATÉRIEL, TOUTE BLESSURE OU LA MORT.

FOR YOUR SAFETY: Do not store or use gasoline or other flammable vapors or liquids in the vicinity of this or any other appliance.

POUR VOTRE SÉCURITÉ: Ne pas entreposer ni utiliser d'essence ni d'autre vapeurs ou liquides inflammables dans le voisinage de cet appareil ou de tout autre appareil.

FOR YOUR SAFETY: What to do if you smell gas:

POUR VOTRE SÉCURITÉ: Que faire si vous sentez une odeur de gaz:

- DO NOT light any appliance.
- DO NOT touch any electrical switches.
- DO NOT use any phone in your building.
- Immediately call your gas supplier from a neighbor's phone. Follow your gas suppliers instructions.
- If your gas supplier cannot be reached, call the fire department.

- Ne pas tenter d'allumer d'appareil.
- Ne touchez à aucun interrupteur. Ne pas vous servir des téléphones se trouvant dans le bâtiment où vous vous trouvez.
- Evacuez la pièce, le bâtiment ou la zone.
- Appelez immédiatement votre fournisseur de gaz depuis un voisin. Suivez les instructions du fournisseur.
- Si vous ne pouvez rejoindre le fournisseur de gaz, appelez le service des incendies.

Installation and service must be performed by a qualified installer, service agency or the gas supplier.

L'installation et service doit être exécuté par un qualifié installateur, agence de service ou le fournisseur de gaz.

Warnock Hersey

WH Report No. J20006712



TABLE OF CONTENTS

| | |
|---|----------------|
| Packaging | page 2 |
| Introduction | page 2 |
| General Information | page 2 |
| Location | page 3 |
| Appliance and Vent Clearances | page 4 |
| Vent Termination Clearances | page 4 |
| Typical Installation Sequence | page 5 |
| Detailed Installation Steps | page 5 |
| Step 1. Framing | page 5 |
| Fireplace Specifications | page 8 |
| Step 2. Routing Gas Line | page 9 |
| Step 3. Install the Venting System . | page 9 |
| Vertical Termination Systems | page 10 |
| Vent Section Length Chart | page 10 |
| Vertical Vent Tables and Figures | page 13 |
| Horizontal Termination System | page 15 |
| Horizontal Vent Tables and Figures . | page 17 |
| Venting Using Flexible Vent Pipe | page 20 |
| Step 4. Millivolt Circuit Wiring | page 21 |
| Step 5. Connecting Gas Line | page 21 |
| Step 6. Installing Logs | page 22 |
| Step 7. Checking Unit Operation | page 22 |
| Step 8. Installing Glass Enclosure Panels | page 22 |
| | page 22 |
| Step 9. Burner Adjustments | page 23 |
| Step 10. Hood Installation | page 23 |
| Finishing Requirements | page 23 |
| Cold Climate Insulation | page 24 |
| Installation Accessories | page 24 |
| Gas Conversion Kits | page 26 |

This installation manual will help you achieve a safe, efficient and dependable installation for your appliance and vent system. **Please read and understand these instructions before beginning your installation.**

DO NOT ATTEMPT TO ALTER OR MODIFY THE CONSTRUCTION OF THE APPLIANCE OR ITS COMPONENTS. ANY MODIFICATION OR ALTERATION MAY VOID THE WARRANTY, CERTIFICATION AND LISTINGS OF THIS UNIT.

PACKAGING

The assembled vented gas fireplace heater is packaged with:

- 1- one log set, with one plastic bag of vermiculite, is packaged in a carton located within the firebox.
- 2- one plastic bag of glowing embers and one plastic bag of decorative volcanic stone is located in the bottom compartment.
- 3 - one envelope containing the literature package which consists of the homeowner's manual, installation instructions, warranty, LP/Propane conversion kit and 8 (DMSTNM-2), 4 (DMPFNM-2) nailing flanges; envelope is located in the control area.
- 4 - one vent restrictor to be applied as shown on **page 9**, restrictor is taped to the envelope.
- 5 - two hoods (DMSTNM-2), or three hoods (DMPFNM-2) taped to the top of the fireplace.

INTRODUCTION

These vented gas fireplace heaters are sealed combustion, air circulating gas fireplaces designed for residential applications. These appliances must be installed with the **Secure Vent™** and /or **Secure Flex™** vent systems routed to the outside atmosphere.

These millivolt appliances are designed to operate on natural or propane gas. They come from the factory setup for natural gas. A natural to propane gas conversion kit is supplied with the fireplace with conversion instructions provided on **page 26**. A millivolt gas control valve with piezo ignition system provides safe and efficient operation.

These appliances comply with National Safety Standards and are tested and listed by Warnock Hersey (Report No. J20006712) to ANSI Z21.88-2000 (in Canada, CSA-2.33-2000), and CAN/CGA-2.17-M91 in both USA and Canada, as vented gas fireplace heaters.

These appliances are listed by Warnock Hersey for installation in bedrooms and mobile homes.

Installation must conform to local codes. In the absence of local codes, installation must comply with the current National Fuel Gas Code, ANSI Z223.1. (In Canada, the current CAN-1 B149 installation code.) Electrical wiring must comply with the National Electrical Code ANSI/NFPA 70 - (latest edition). (In Canada, the current CSA C22-1 Canadian Electrical Code.) For additional installation requirements when these appliances are to be installed as an OEM installation in a manufactured home, refer to the manufactured home construction and safety standard, *Title 24, Part 3280 CFP* or standard for *Installation in Mobile Homes, CAN/CSA Z240MH*.

NOTE: DIAGRAMS & ILLUSTRATIONS NOT TO SCALE.

GENERAL INFORMATION

Note: Installation and repair should be performed by a qualified service person. The appliance should be inspected annually by a qualified professional service technician. More frequent inspections and cleanings may be required due to excessive lint from carpeting, bedding material, etc. It is imperative that the control compartment, burners and circulating air passage ways of the appliance be kept clean.

S'assurer que le brûleur et le compartiment des commandes sont propres. Voir les instructions d'installation et d'utilisation qui accompagnent l'appareil.

Provide adequate clearances around air openings and adequate accessibility clearance for service and proper operation. Never obstruct the front, back and/or side viewing surfaces of the appliance.

These appliances are designed to operate on natural or propane gas only. The use of other fuels or combination of fuels will degrade the performance of this system and may be dangerous.

TYPICAL INSTALLATION

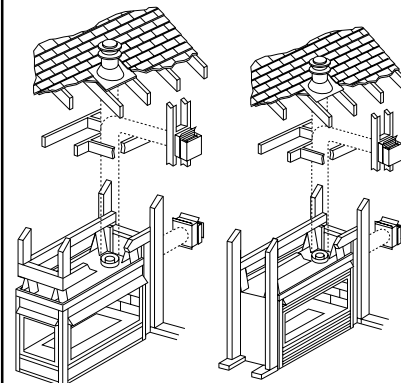

DMPFNM-2 **DMSTNM-2**
Figure 1

Millivolt Models -

Millivolt models come standard with the manually-modulated gas valve; flame appearance and heat output can be controlled at the gas valve.

Input of millivolt models is shown in the following table:

| Millivolt Models | |
|--------------------------------|---------------------------------------|
| Natural and Propane Gas Models | Input rate (BTU/H) Manually-modulated |
| DMSTNM-2 DMPFNM-2 | 30,000 TO 37,500 |

Maximum manifold pressure is 3.5 in. w.c. (0.87 kPa) for natural gas and 10 in. w.c. (2.49 kPa) for LP/Propane gas.

Installations at Altitudes of 0 to 4500 ft.-

Units are tested and approved for elevations of 0 to 4500 feet (0 to 1372 meters).

Installations at Altitudes above 4500 ft.-

For elevations above 4500 feet (1372 meters), install the unit according to the regulations of the local authorities having jurisdiction and, in the USA, the latest edition of the National Fuel Gas Code (ANSI Z223.1) or, in Canada, the latest edition of the CAN1-B149.1 and .2 codes.

Table 1 shows the units' gas orifice size for the elevations indicated.

| Model No. | Orifice size* | | Elevation Feet (meters) |
|----------------------|---------------|-------|-------------------------|
| | Nat. | Prop. | |
| DMSTNM-2 DMPFNM-2 | #44 | #55 | 0-4500 (0-1370) |

* Each model has two burners. Each burner contains one of these orifices.

Table 1

The millivolt appliances are manually controlled and feature a spark ignitor (piezo) that allows the appliance's pilot gas to be lit without the use of matches or batteries. This system will still function in the event of a power outage.

Do not use these appliances if any part has been under water. Immediately call a qualified, professional service technician to inspect the appliance and to replace any parts of the control system and any gas control which have been under water.

Ne pas se servir de cet appareil s'il a été plongé dans l'eau, complètement ou en partie. Appeler un technicien qualifié pour inspecter l'appareil et remplacer toute partie du système de contrôle et toute commande qui ont été plongés dans l'eau.

This appliance may be installed as an OEM installation in a manufactured home (USA only) or mobile home and must be installed in accordance with the manufacturer's instructions and the Manufactured Home Construction and Safety Standard, Title 24 CPF, Part 3280 or Standard for Installation in Mobile Homes, CAN/CSA Z240 MH.

This appliance is only for use with the type(s) of gas indicated on the rating plate. A conversion kit is supplied with the appliance.

Cet appareil peut être installé comme du matériel d'origine dans une maison préfabriquée (É.-U. seulement) ou mobile et doit être installé selon les instructions du fabricant et conformément à la norme Manufactured Home Construction and Safety Standard, Title 24 CPF, Part 3280 ou à la norme CAN/CSA Z240 Série MM, Maisons Mobiles.

Cet appareil doit être utilisé uniquement avec les types de gaz indiqués sur la plaque signalétique. Une trousse de conversion est fournie avec l'appareil.

Test gage connections are provided on the front of the millivolt gas control valve (identified IN for the inlet and OUT for the manifold side).

Minimum inlet gas pressure to these appliances is 5.0 inches water column (1.24 kPa) for natural gas and 11.0 inches water column (2.74 kPa) for propane for the purpose of input adjustment.

Maximum inlet gas supply pressure to these appliances is 10.5 inches water column (2.61 kPa) for natural gas and 13.0 inches water column (3.23 kPa) for propane.

These appliances must be isolated from the gas supply piping system (by closing their individual manual shut-off valve) during any pressure testing of the gas supply piping system at test pressures equal to or less than 1/2 psig (3.5 kPa).

These appliances and their individual shut-off valves must be disconnected from the gas supply piping system during any pressure testing of that system at pressures in excess of 1/2 psig (3.5 kPa).

These appliances must not be connected to a chimney or flue serving a separate solid fuel burning appliance.

Carbon Monoxide Poisoning: Early signs of carbon monoxide poisoning are similar to the flu with headaches, dizziness and/or nausea. If you have these signs, obtain fresh air immediately. Turn off the gas supply to the appliance and have it serviced by a qualified professional, as it may not be operating correctly.

NOTE: DIAGRAMS & ILLUSTRATIONS NOT TO SCALE.

WARNING: FAILURE TO COMPLY WITH THE INSTALLATION AND OPERATING INSTRUCTIONS PROVIDED IN THIS DOCUMENT WILL RESULT IN AN IMPROPERLY INSTALLED AND OPERATING APPLIANCE, VOIDING ITS WARRANTY. ANY CHANGE TO THIS APPLIANCE AND/OR ITS OPERATING CONTROLS IS DANGEROUS. IMPROPER INSTALLATION OR USE OF THIS APPLIANCE CAN CAUSE SERIOUS INJURY OR DEATH FROM FIRE, BURNS, EXPLOSION OR CARBON MONOXIDE POISONING.

WARNING: CHILDREN AND ADULTS SHOULD BE ALERTED TO THE HAZARDS OF HIGH SURFACE TEMPERATURES. USE CAUTION AROUND THE APPLIANCE TO AVOID BURNS OR CLOTHING IGNITION. YOUNG CHILDREN SHOULD BE CAREFULLY SUPERVISED WHEN THEY ARE IN THE SAME ROOM AS THE APPLIANCE.

WARNING: DO NOT PLACE CLOTHING OR OTHER FLAMMABLE MATERIALS ON OR NEAR THIS APPLIANCE.

AVERTISSEMENT: SURVEILLER LES ENFANTS. GARDER LES VÊTEMENTS, LES MEUBLES, L'ESSENCE OU AUTRES LIQUIDES À VAPEUR INFLAMMABLES À CÔTÉ DE L'APPAREIL.

LOCATION

In selecting the location, the aesthetic and functional use of the appliance are primary concerns. However, vent system routing to the outside atmosphere and access to the fuel supply are also important. Consideration should be given to traffic ways, furniture, draperies, etc., due to high surface temperatures (Figure 2). The location should also be free of electrical, plumbing or other heating/air conditioning ducting.

These direct vent appliances are uniquely suited for installations requiring a utility shelf positioned directly above the fireplace. Utility shelves like these are commonly used for locating television sets and decorative plants.

To achieve the lowest possible shelf height, use the alternative rear vent outlet. Do not insulate the space between the appliance and the area above it. See Figure 3 on page 4. The minimum height from the base of the appliance to the underside of combustible materials used to construct a utility shelf in this fashion is shown in the table in Figure 3 on page 4. The weight of the utility shelf and anything placed upon it may not be supported by the appliance in anyway.

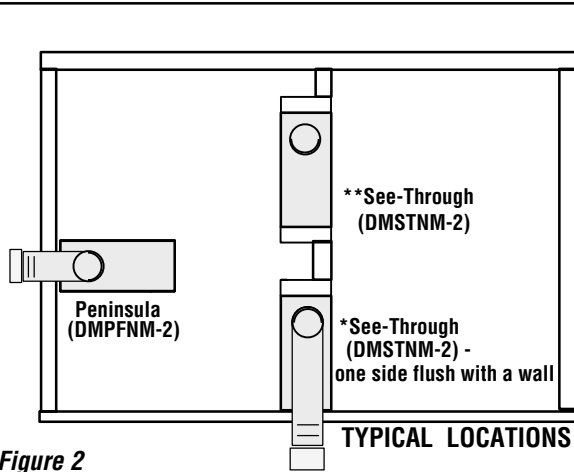
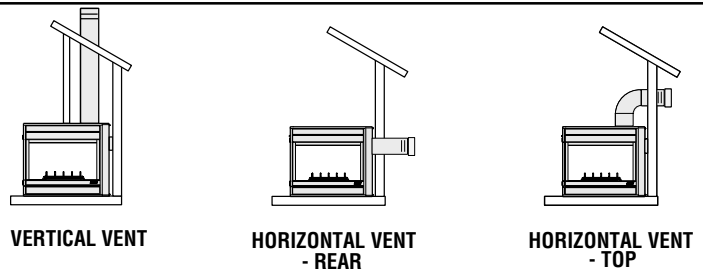

Figure 2



*When See-Through (DMSTNM-2) is installed with one side flush with a wall, opposite wall must not extend beyond either viewing side of the fireplace.
 **When See-Through (DMSTNM-2) is installed in the middle of a room, do not extend side walls beyond either viewing side of the fireplace.

Note - The side walls of mantels may protrude beyond the front face of the fireplace a maximum of 5 inches (127mm) at 0 inch clearance to the sides of the fireplace. See Figure 54 on page 24 for mantel clearances above the fireplace.

The appliance should be mounted on a fully supported base extending the full width and depth of the unit. The appliance may be located on or near conventional construction materials. However, if installed on combustible materials, such as carpeting, vinyl tile, etc., a metal or wood barrier covering the entire bottom surface must be used.

APPLIANCE AND VENT CLEARANCES

The appliance is approved with zero clearance to combustible materials on all sides (as detailed in Table 2), with the following exception: When the unit is installed with one side flush with a wall, the wall on the other side of the unit must not extend beyond the front edge of the unit. In addition, when the unit is installed in the middle of a room, the side walls surrounding the unit must not extend beyond the front or rear edge of the unit. See Figure 2.

| | |
|--------------------------------------|---|
| BACK | 1/2 in. (13 mm) 0 in. (0 mm) spacers |
| SIDES | 1/2 in. (13 mm) 0 in. (0 mm) spacers |
| TOP SPACERS | 0 in. (0 mm) |
| FLOOR | 0 in. (0 mm) |
| From Bottom of Unit to Ceiling | 64 in. (1626 mm) |
| VENT | 1 in. (25.4 mm)* |
| SERVICE CLEARANCES | |
| VIEWING SIDES - (FRONT BACK OR SIDE) | 3 Feet. (0.9 meters) |

*Note: 3 in. (75 mm) above any horizontal/inclined vent component.

Table 2

| Model No. | Shelf Height inches (mm) | | | |
|-----------|-------------------------------------|-------------|-----------------------------------|-------------|
| | Top Vent - with One 90 Degree Elbow | | Rear Vent - Straight Out the Back | |
| | Secure Vent | Secure Flex | Secure Vent | Secure Flex |
| DMSTNM-2 | 48¾ (1238) | 52½ (1334) | 41⅞ (1045) | 41⅞ (1045) |
| DMPFNM-2 | | | | |

Note - The weight of the utility shelf and anything placed upon it may not be supported by the appliance in anyway.

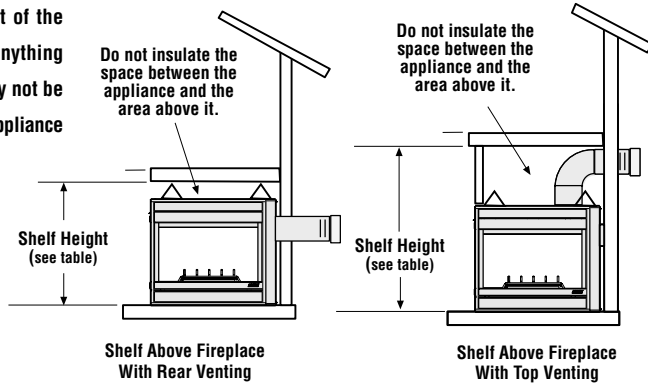

Figure 3

VENT TERMINATION CLEARANCES

These instructions should be used as a guideline and do not supersede local codes in any way. Install vent according to local codes, these instructions, the current National Fuel Gas Code (ANSI-Z223.1) in the USA or the current standards of CAN/CGA-B149.1 and -B149.2 in Canada. For additional installation requirements when these appliances are to be installed as an OEM installation in a manufactured home, refer to the manufactured home construction and safety standard, Title 24, Part 3280 CFP or standard for Installation in Mobile Homes, CAN/CSA Z240MH.

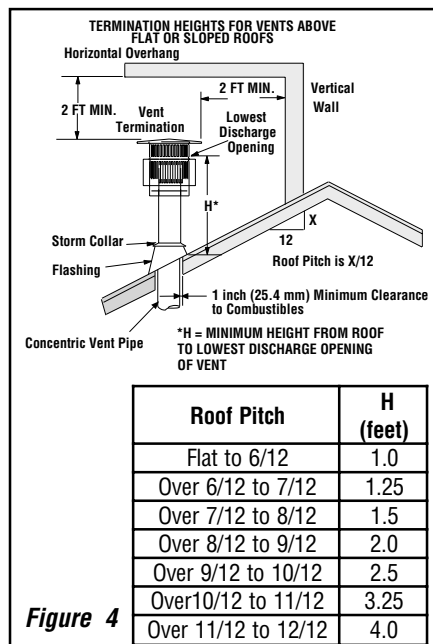

Figure 4

Vertical Vent Termination Clearances

Terminate single vent caps relative to building components according to **Figure 4**.

Terminate multiple vent terminations according to the installation codes listed above.

Horizontal Vent Termination Clearances

See **Figure 5** for horizontal vent termination clearances to any overhead combustible projection less than or equal to 2 1/2" (64 mm) and greater than 2 1/2" (64 mm). For additional vent location restrictions refer to **Figure 8 on page 6**.

TYPICAL INSTALLATION SEQUENCE

The typical sequence of installation follows, however, each installation is unique resulting in variations to those described.

See the page numbers references in the following steps for detailed procedures.

Step 1. (page 5) Construct the appliance framing. Position the appliance within the framing and secure with nailing brackets.

Step 2. (page 9) Route gas supply line to appliance location.

Step 3. (page 9) Install the vent system and exterior termination.

Step 4. (page 21) Millivolt Circuit Wiring

Step 5. (page 21) Make connection to gas supply.

Step 6. (page 22) Install the log set, vermiculite and ceramic fiber chunks.

Step 7. (page 22) Checkout appliance operation.

Step 8. (page 22) Install glass enclosure panels.

Step 9. (page 23) Adjust burner primary air shutter to achieve proper flame appearance.

Step 10. (page 23) Install the hoods.

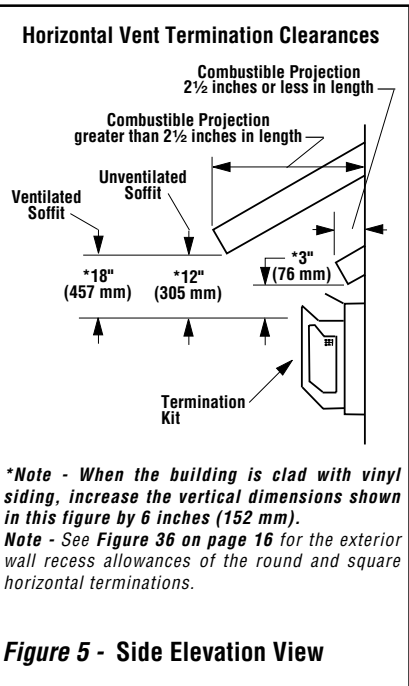

Figure 5 - Side Elevation View

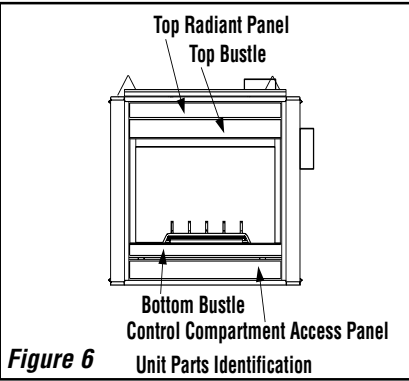

Figure 6

DETAILED INSTALLATION STEPS

The appliance is shipped with all gas controls and components installed and pre-wired.

- 1 - Remove the shipping carton.
- 2 - Remove the top radiant panel (*see Figure 6*).
- 3 - Lift the pressure relief plates and remove the cardboard from underneath each of them.
- 4 - Open the control compartment access panel, by actuating the spring-loaded magnetic catches securing the panel, gently depressing the outer top corners of the panel until the catches "pop" the panel free and allowing it to swing out and down to open.
- 5 - Locate the two (2) latches at the top of the control compartment. To disengage the two latches from the bottom vee-flange of the glass enclosure panel, reach for the handles located towards the back of the latches and pull the handles down toward the front of the unit. Swing the bottom of the door out and raise it slightly to lift the top flange of the door frame away from the appliance. Set the door aside protecting it from inadvertent damage. *See Figure 52 on page 22*.

NOTE: DIAGRAMS & ILLUSTRATIONS NOT TO SCALE.

Step 1. FRAMING

Frame these appliances as illustrated in **Figures 9 (DMSTNM-2), 10 (DMPFNM-2)** on page 7. All framing details must allow for a minimum clearance to combustible framing members as shown in **Table 2 on page 4**.

If the appliance is to be elevated above floor level, a solid continuous platform must be constructed. Headers may be in direct contact with the appliance top spacers but must not be supported by them or notched to fit around them. All construction above the appliance must be self supporting, **DO NOT** use the appliance for structural support.

Side Nailing Flanges

The fireplace should be secured to the framing at the side(s) of the unit using the factory-provided nailing flanges. Install the nailing flanges - 8 (DMSTNM-2), 4 (DMPFNM-2) - as shown in **Figure 7** using the existing screws. Position the fireplace within the framing. When required, the flanges may be bent 90 degrees by hand or with the assistance of a hammer. Use wood screws to secure the nailing flanges to the framing. *See Table 2 on page 4* for clearances of framing members to cabinet parts in the nailing flange area. The nailing flange itself is exempt from these clearances.

Floor Nailing Tabs

Secure the fireplace to the floor as shown in **Figure 7**.

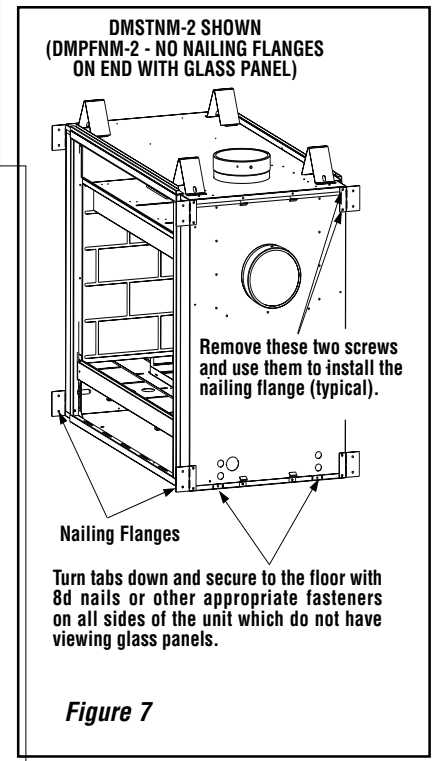
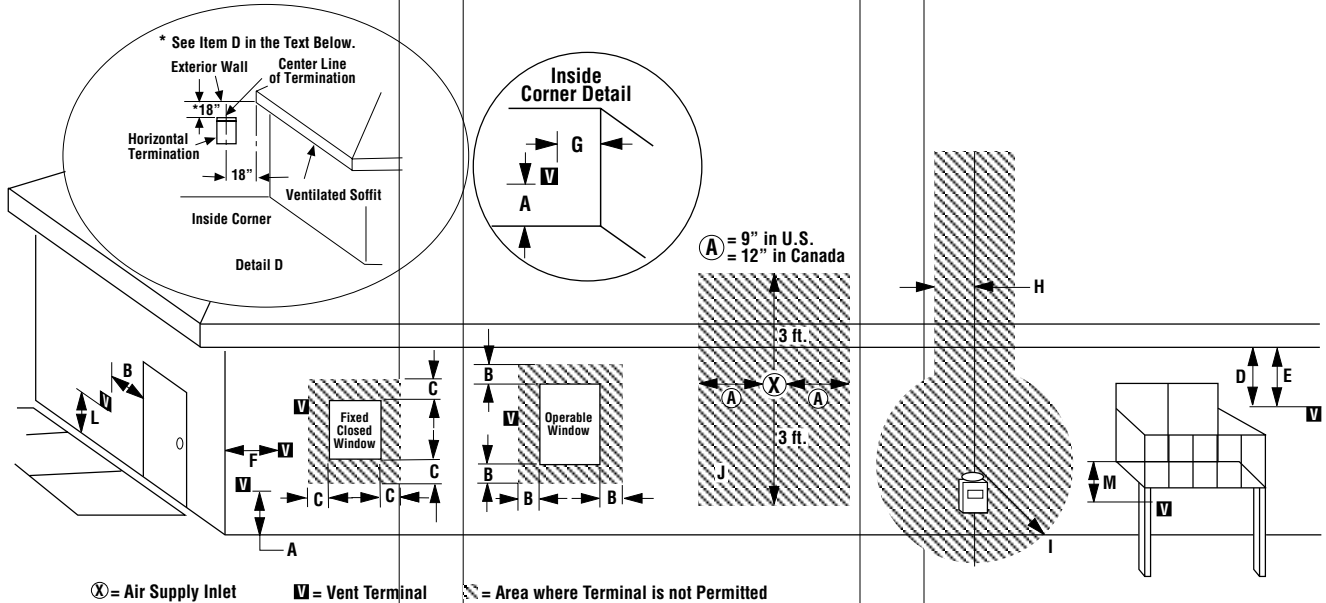

Figure 7

EXTERIOR HORIZONTAL VENT TERMINATION CLEARANCE REQUIREMENTS



⊗ = Air Supply Inlet ■ V = Vent Terminal ▨ = Area where Terminal is not Permitted

- A = clearance above grade, veranda, porch, deck, or balcony
12 inches (30.5 cm) minimum
- B = clearance to window or door that may be opened
12 inches (30.5 cm) minimum
- C = clearance to permanently closed window - recommended to prevent condensation on window
U.S. - 9 inches (22.8 cm) minimum
Canada - 12 inches (30.5 cm) minimum
- D = vertical clearance to ventilated soffit located above the terminal (if any part of the soffit is within a horizontal distance of 18 in. (45.7 cm) from the center line of the terminal) - see detail D above
18 inches (45.7 cm) minimum for all materials except vinyl clad soffit;
24 inches (61.0 cm) minimum for vinyl clad soffit.
- E = vertical clearance to unventilated soffit
12 inches (30.5 cm) minimum for all materials except vinyl clad soffit;
18 inches (45.7 cm) minimum for vinyl clad soffit.
- F = clearance to outside corner
5 inches (12.7 cm) minimum
- G = clearance to inside corner
6 inches (15.2 cm) minimum
- H = not be installed above a gas service meter/regulator assembly within 3 feet (91.4 cm) horizontally from the center line of the gas service regulator.
- I = clearance to gas service regulator vent outlet
3 feet (91.4 cm) minimum
- J = non-mechanical inlet (includes combustion air intake for a direct vent appliance or any other inlet not providing ventilation air for living spaces):
 - vent termination ■ V may not be located in an area bounded by lines drawn 9 inches to the left and right of the non-mechanical inlet ⊗ X cap sides (12 inches in Canada) and extending 3 feet above and below the termination
- K = clearance to mechanical air supply (outside air inlet used to provide ventilation air to living spaces within the structure):
at least 3 ft. (91.4 cm) above inlet when vent within 10 ft. of inlet - U.S.
at least 6 ft. (182.8 cm) - Canada
- L = clearance above paved sidewalk or paved driveway located on public property
7 feet (2.1 m) minimum
- M = clearance under veranda, porch, deck, or balcony where fully open on a minimum of two (2) sides beneath the floor
12 inches (30.5 cm) minimum

Note: Clearances are measured from the nearest adjacent vent point where exhaust gases exit the flue (vent side to vent side).

Note: A vent shall not terminate directly above a sidewalk or paved driveway which is located between two (2) single family dwellings and serves both dwellings.

Note: Always Check local codes or regulations for variations.
For SI units: 1 foot = 0.305 m

NOTE: DIAGRAMS & ILLUSTRATIONS NOT TO SCALE.

Figure 8

FIREPLACE FRAMING SPECIFICATIONS

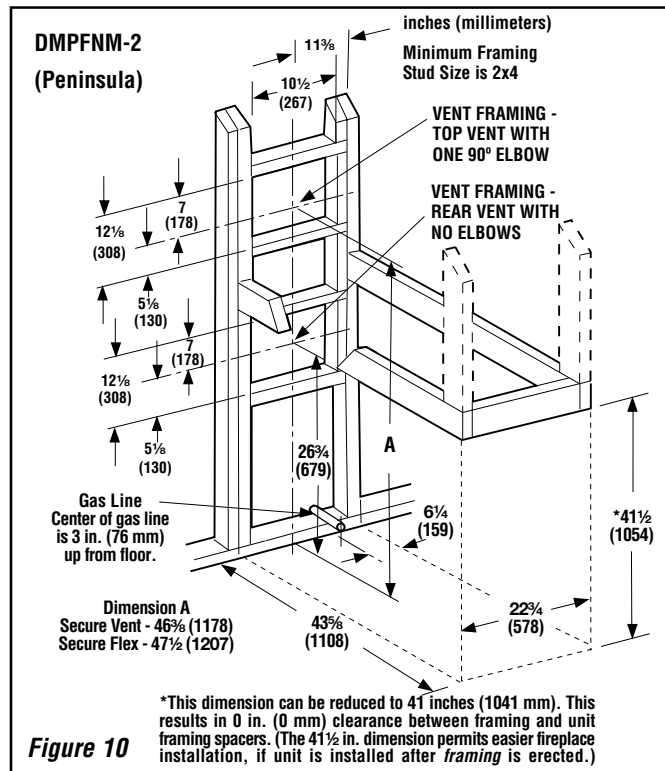
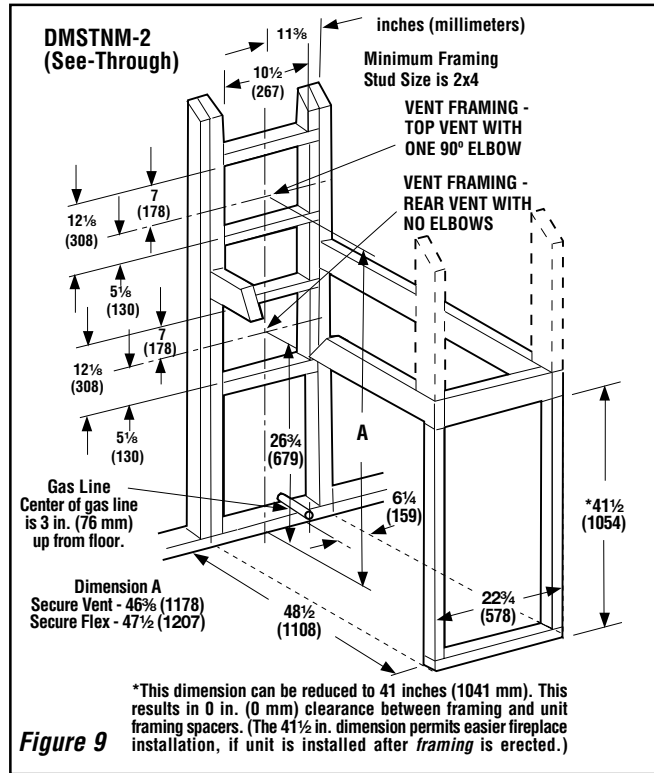

FIREPLACE SPECIFICATIONS

DMSTNM-2 (See-Through)

Figure 11

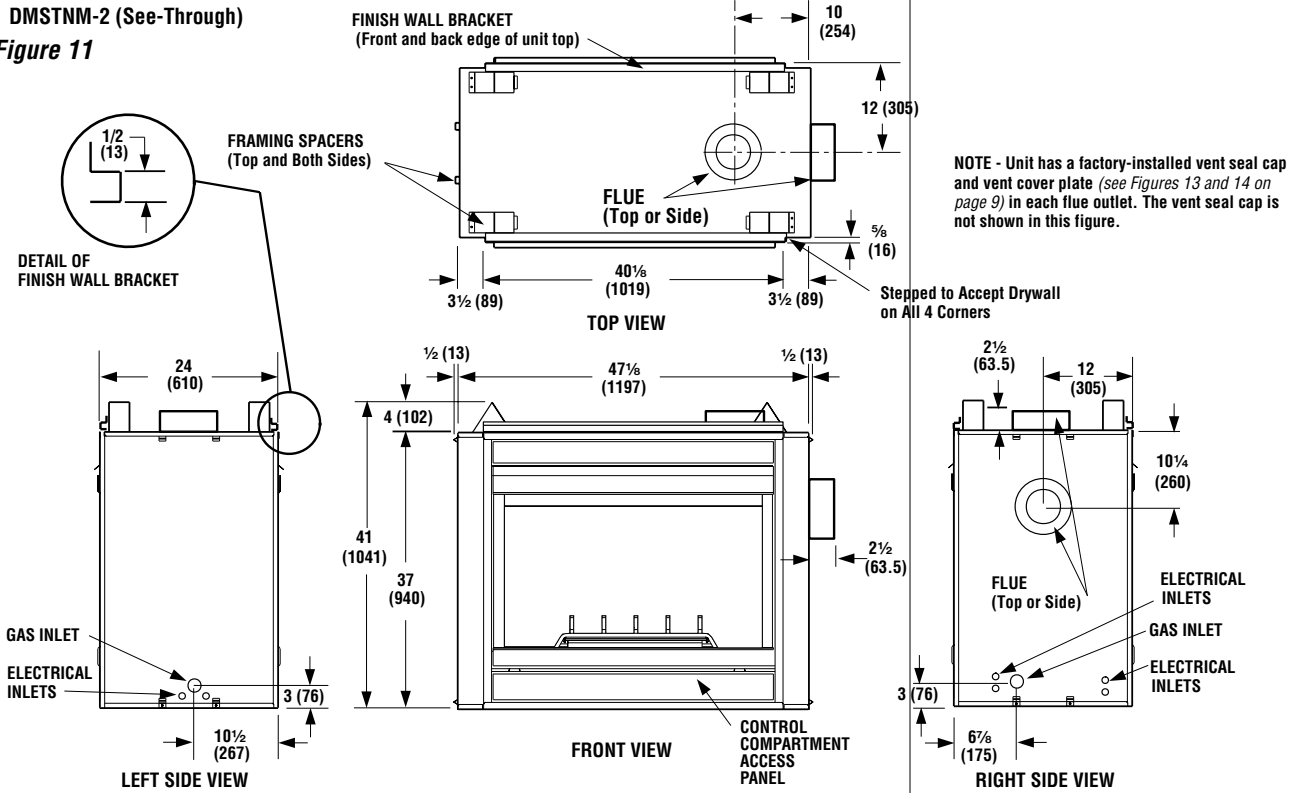

DMPFNM-2 (Peninsula)

Figure 12

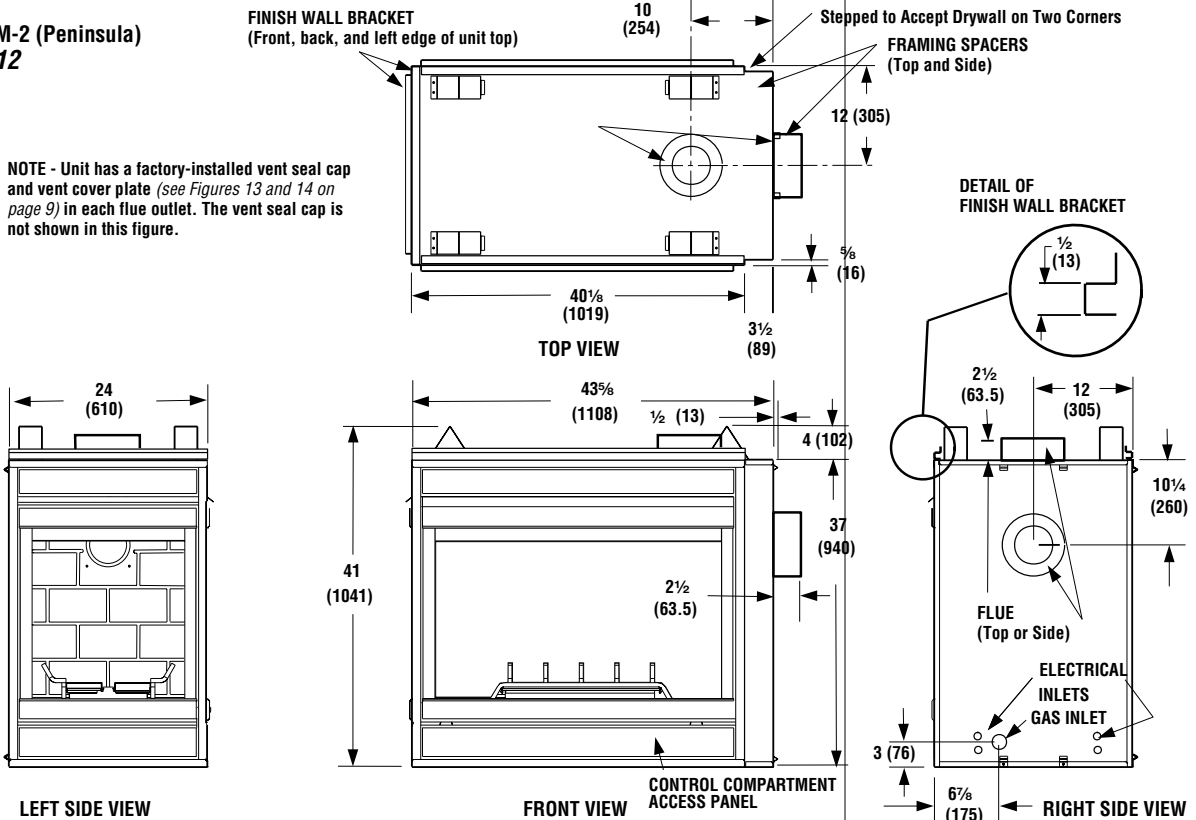

NOTE: DIAGRAMS & ILLUSTRATIONS NOT TO SCALE.

Step 2. ROUTING GAS LINE

Route a ½" (13 mm) gas line as shown in **Figure 9 (DMSTNM-2)**, **10 (DMPFNM-2)** on **page 7**. Gas lines must be routed, constructed and made of materials that are in strict accordance with local codes and regulations. All appliances are factory-equipped with a flexible gas line connector and ½ inch shutoff valve. (See **step 5** on **page 21**).

Step 3. INSTALL THE VENT SYSTEM

General Information

These instructions should be used as a guideline and do not supersede local codes in any way. Install vent according to local codes, these instructions, the current National Fuel Gas Code (ANSI-Z223.1) in the USA or the current standards of CAN/CGA-B149.1 and -B149.2 in Canada. For additional installation requirements when these appliances are to be installed as an OEM installation in a manufactured home, refer to the manufactured home construction and safety standard, *Title 24, Part 3280 CFP* or standard for *Installation in Mobile Homes, CAN/CSA Z240MH*.

These fireplaces are designed, tested and listed for operation and installation only with Secure Vent™ (SV 4.5) Direct Vent System Components or Secure Flex™ Flexible Vent Components manufactured by Security Chimneys International. These approved vent system components are labeled for identification. **DO NOT** use any other manufacturer's vent components with these appliances. These fireplaces must be vented directly to the outside.

The vent system must not service multiple appliances, and must never be connected to a flue serving a solid fuel burning appliance. The vent pipe is tested to be run inside an enclosure (such as a chase). There is no requirement for inspection openings in the enclosure at any of the joints in the vent pipe.

Preparing the Appliance Vent Collar

Each of the unit's two vent collars are sealed with a cover plate, and a seal cap. The cover plate and seal cap must be removed from the vent collar being used. Refer to **figure 13** for top vent usage and **figure 14** for side, and the following steps to prepare the appropriate collar for use.

From the vent collar being used, remove the two screws securing the vent seal cap. Twist the cap counterclockwise. Pull it away from the unit and discard, along with the piece of insulation.

When the top vent collar is being used, from inside the firebox, loosen the two screws in the keyhole slots of the cover plate and remove the remaining two cover plate securing screws. Remove and discard the cover plate. **Reinstall and securely tighten all four screws.**

When the side vent collar is being used, from inside the firebox, loosen the two screws in the keyhole slots of the cover plate and remove the remaining two cover plate securing screws. Remove and discard the cover plate. **Reinstall and securely tighten all four screws.**

WARNING:
FAILURE TO REINSTALL AND SECURELY TIGHTEN COVER PLATE SCREWS COULD RESULT IN LEAKAGE OF FLUE PRODUCTS INTO THE LIVING SPACE. VENT COVER PLATE AND VENT SEAL CAP MUST REMAIN SECURELY INSTALLED ON UNUSED VENT COLLAR. FAILURE TO DO SO COULD RESULT IN LEAKAGE OF FLUE PRODUCTS INTO LIVING SPACE.

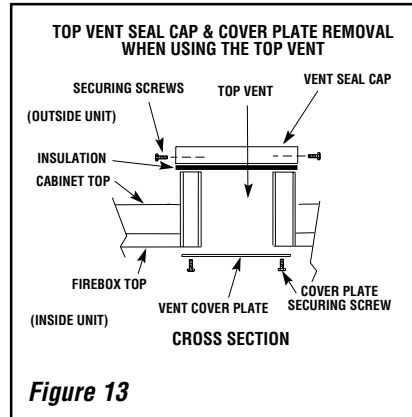

Figure 13

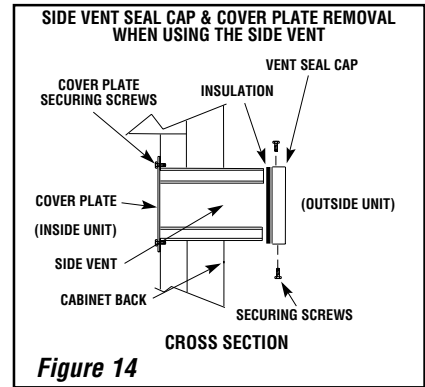

Figure 14

Preparing the Appliance Top or Side Vent Outlet when vertically terminating the vent system above the roof

Install a vent restrictor (provided) in the appliance top flue outlet as shown in **Figure 15** or side flue outlet as shown in **Figure 16** when vertically terminating the vent system above the roof. It may be installed either from inside or outside the unit, in the inner fireplace collar. It is press-fitted in place.

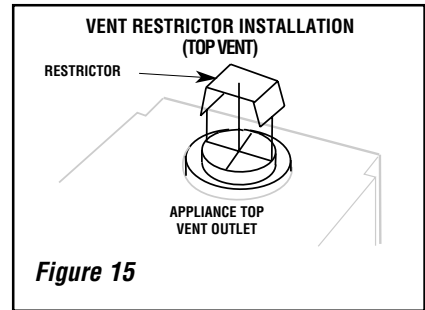

Figure 15

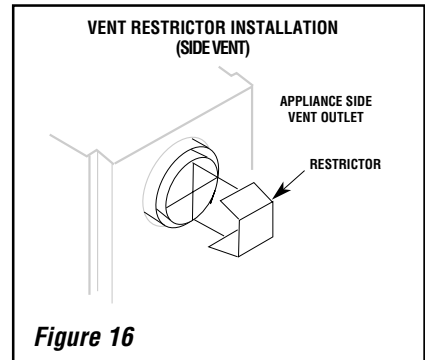

Figure 16

Select Venting System - Horizontal or Vertical

With the appliance secured in framing, determine vent routing and identify the exterior termination location. The following sections describe vertical (roof) and horizontal (exterior wall) vent applications. Refer to the section relating to your installation. **A list of approved venting components is shown in the tables on pages 24 and 25.**

VERTICAL TERMINATION SYSTEMS (ROOF)

Figure 17, and Figures 29 through 33 on pages 13 and 14 and their associated Vertical Vent Tables illustrate the vertical venting configurations that are allowed to be used with these appliances. **Secure Vent** pipe applications are shown in these figures; **Secure Flex** pipe may also be used. See page 20. A Vertical Vent Table summarizes each system's minimum and maximum vertical and horizontal length values that can be used to design and install the vent components in a variety of applications. Both these vertical vent systems terminate through the roof. In the USA, the minimum vent height above the roof and/or adjacent walls is specified in ANSI Z223.1 (latest edition); in Canada, by the current CAN-1 B149 installation code. It is also specified in major building codes. Always consult your local codes for specific requirements. A general guide to follow is the Gas Vent Rule (refer to Figure 4 on page 4).

Vertical (Straight) Installation

Determine the number of straight vent sections required. 4 1/2" (114 mm), 10 1/2" (267 mm), 22 1/2" (572 mm), 34 1/2" (876 mm) and 46 1/2" (1181 mm) net section lengths are available. Plan the vent lengths so that a section joint does not occur within the space defined by ceiling joists or roof rafters. Refer to the Vent Section Length Chart.

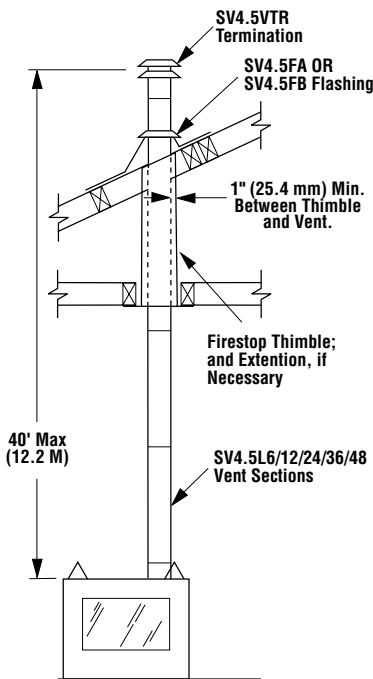

Figure 17

| VENT SECTION LENGTH CHART | | | | | | | TOTAL QTY |
|---------------------------------|-------------------------|--------|--------|--------|--------|---|--------------|
| Nominal Section Length (inches) | 6 | 12 | 24 | 36 | 48 | | |
| Net Section Length (inches) | 4-1/2 | 10-1/2 | 22-1/2 | 34-1/2 | 46-1/2 | | |
| Height of Vent | Number of Vent Sections | | | | | | |
| inches | ft | | | | | | |
| 4.5 | 0.375 | 1 | 0 | 0 | 0 | 0 | 1 |
| 9 | 0.75 | 2 | 0 | 0 | 0 | 0 | 2 |
| 10.5 | 0.875 | 0 | 1 | 0 | 0 | 0 | 1 |
| 15 | 1.25 | 1 | 1 | 0 | 0 | 0 | 2 |
| 19.5 | 1.625 | 2 | 1 | 0 | 0 | 0 | 3 |
| 21 | 1.75 | 0 | 2 | 0 | 0 | 0 | 2 |
| 22.5 | 1.875 | 0 | 0 | 1 | 0 | 0 | 1 |
| 25.5 | 2.125 | 1 | 2 | 0 | 0 | 0 | 3 |
| 31.5 | 2.625 | 0 | 3 | 0 | 0 | 0 | 3 |
| 34.5 | 2.875 | 0 | 0 | 0 | 1 | 0 | 1 |
| 37.5 | 3.125 | 1 | 1 | 1 | 0 | 0 | 3 |
| 43.5 | 3.625 | 0 | 2 | 1 | 0 | 0 | 3 |
| 45 | 3.75 | 0 | 0 | 2 | 0 | 0 | 2 |
| 46.5 | 3.875 | 0 | 0 | 0 | 0 | 1 | 1 |
| 49.5 | 4.125 | 1 | 0 | 2 | 0 | 0 | 3 |
| 51 | 4.25 | 1 | 0 | 0 | 0 | 1 | 2 |
| 55.5 | 4.625 | 0 | 1 | 2 | 0 | 0 | 3 |
| 57 | 4.75 | 0 | 0 | 1 | 1 | 0 | 2 |
| 66 | 5.25 | 0 | 2 | 2 | 0 | 0 | 4 |
| 67.5 | 5.625 | 0 | 0 | 3 | 0 | 0 | 3 |
| 69 | 5.75 | 0 | 0 | 0 | 2 | 0 | 2 |
| 72 | 6 | 1 | 0 | 3 | 0 | 0 | 4 |
| 73.5 | 6.125 | 1 | 0 | 0 | 2 | 0 | 3 |
| 79.5 | 6.625 | 0 | 1 | 0 | 2 | 0 | 3 |
| 81 | 6.75 | 0 | 0 | 0 | 1 | 1 | 2 |
| 90 | 7.5 | 0 | 2 | 1 | 0 | 1 | 4 |
| 91.5 | 7.625 | 0 | 0 | 2 | 0 | 1 | 3 |
| 93 | 7.75 | 0 | 0 | 0 | 0 | 2 | 2 |
| 96 | 8 | 1 | 0 | 1 | 2 | 0 | 4 |
| 97.5 | 8.125 | 1 | 0 | 0 | 0 | 2 | 3 |
| 102 | 8.5 | 2 | 0 | 0 | 0 | 2 | 4 |
| 103.5 | 8.625 | 0 | 0 | 0 | 3 | 0 | 3 |
| 108 | 9 | 1 | 0 | 0 | 3 | 0 | 4 |
| 114 | 9.5 | 0 | 2 | 0 | 0 | 2 | 4 |
| 117 | 9.75 | 1 | 0 | 5 | 0 | 0 | 6 |
| 118.5 | 9.875 | 1 | 1 | 0 | 3 | 0 | 5 |
| 126 | 10.5 | 0 | 0 | 1 | 3 | 0 | 4 |
| 130.5 | 10.875 | 1 | 0 | 1 | 3 | 0 | 5 |
| 135 | 11.25 | 0 | 0 | 6 | 0 | 0 | 6 |
| 138 | 11.5 | 0 | 0 | 0 | 4 | 0 | 4 |
| 139.5 | 11.625 | 0 | 0 | 0 | 0 | 3 | 3 |
| 142.5 | 11.875 | 1 | 0 | 0 | 4 | 0 | 5 |

Vertical (Offset) Installation

Analyze the vent routing and determine the number of vent sections and elbows required. Refer to Vertical Vent Figures and Tables on page 13 and 14 to select the type of vertical installation desired. Vent sections are available in net lengths of 4 1/2" (114 mm), 10 1/2" (267 mm), 22 1/2" (572 mm), 34 1/2" (876 mm) and 46 1/2" (1181 mm). Refer to the Vent Section Length Chart above for an aid in selecting length combinations.

NOTE: DIAGRAMS & ILLUSTRATIONS NOT TO SCALE.

| VENT SECTION LENGTH CHART | | | | | | | TOTAL QTY |
|---------------------------------|-------------------------|--------|--------|--------|--------|----|--------------|
| Nominal Section Length (inches) | 6 | 12 | 24 | 36 | 48 | | |
| Net Section Length (inches) | 4-1/2 | 10-1/2 | 22-1/2 | 34-1/2 | 46-1/2 | | |
| Height of Vent | Number of Vent Sections | | | | | | |
| inches | ft | | | | | | |
| 144 | 12 | 1 | 0 | 0 | 0 | 3 | 4 |
| 150 | 12.5 | 0 | 1 | 0 | 0 | 3 | 4 |
| 154.5 | 12.875 | 1 | 1 | 0 | 0 | 3 | 5 |
| 160.5 | 13.375 | 0 | 2 | 0 | 0 | 3 | 5 |
| 172.5 | 14.375 | 0 | 0 | 0 | 5 | 0 | 5 |
| 177 | 14.75 | 1 | 0 | 0 | 5 | 0 | 6 |
| 183 | 15.25 | 0 | 1 | 0 | 5 | 0 | 6 |
| 186 | 15.5 | 0 | 0 | 0 | 0 | 4 | 4 |
| 190.5 | 15.875 | 1 | 0 | 0 | 0 | 4 | 5 |
| 196.5 | 16.375 | 0 | 1 | 0 | 0 | 4 | 5 |
| 205.5 | 17.125 | 0 | 1 | 1 | 5 | 0 | 7 |
| 207 | 17.25 | 0 | 0 | 0 | 6 | 0 | 6 |
| 211.5 | 17.625 | 1 | 0 | 0 | 6 | 0 | 7 |
| 217.5 | 18.125 | 0 | 1 | 0 | 6 | 0 | 7 |
| 229.5 | 19.125 | 0 | 0 | 1 | 6 | 0 | 7 |
| 232.5 | 19.375 | 0 | 0 | 0 | 0 | 5 | 5 |
| 237 | 19.75 | 1 | 0 | 0 | 0 | 5 | 6 |
| 241.5 | 20.125 | 0 | 0 | 0 | 7 | 0 | 7 |
| 246 | 20.5 | 1 | 0 | 0 | 7 | 0 | 8 |
| 252 | 21 | 0 | 1 | 0 | 7 | 0 | 8 |
| 264 | 22 | 0 | 0 | 1 | 7 | 0 | 8 |
| 276 | 23 | 0 | 0 | 0 | 8 | 0 | 8 |
| 279 | 23.25 | 0 | 0 | 0 | 0 | 6 | 6 |
| 280.5 | 23.375 | 1 | 0 | 0 | 8 | 0 | 9 |
| 283.5 | 23.625 | 1 | 0 | 0 | 0 | 6 | 7 |
| 289.5 | 24.125 | 0 | 1 | 0 | 0 | 6 | 7 |
| 301.5 | 25.125 | 0 | 0 | 1 | 0 | 6 | 7 |
| 310.5 | 25.875 | 0 | 0 | 0 | 9 | 0 | 9 |
| 315 | 26.5 | 1 | 0 | 0 | 9 | 0 | 10 |
| 325.5 | 27.125 | 0 | 0 | 0 | 0 | 7 | 7 |
| 330 | 27.5 | 1 | 0 | 0 | 0 | 7 | 8 |
| 336 | 28 | 0 | 1 | 0 | 0 | 7 | 8 |
| 345 | 28.75 | 0 | 0 | 0 | 10 | 0 | 10 |
| 349.5 | 29.125 | 1 | 0 | 0 | 10 | 0 | 11 |
| 372 | 31 | 0 | 0 | 0 | 0 | 8 | 8 |
| 376.5 | 31.375 | 1 | 0 | 0 | 0 | 8 | 9 |
| 379.5 | 31.625 | 0 | 0 | 0 | 11 | 0 | 11 |
| 418.5 | 34.875 | 0 | 0 | 0 | 0 | 9 | 9 |
| 423 | 35.25 | 1 | 0 | 0 | 0 | 9 | 10 |
| 465 | 38.75 | 0 | 0 | 0 | 0 | 10 | 10 |

Elbows are available in 45° and 90° configurations. Refer to Figure 24 on 12 for the SV4.5E45 and SV4.5E90 elbow dimensional specifications.

Where required, a telescopic vent section (SV4.5LA) may be used to provide the installer with an option in installing in tight and confined spaces or where the vent run made up of fixed length pieces develops a joint in a undesirable location, or will not build up to the required length.

The SV4.5LA Telescopic Vent Section has an effective length of from 1 1/2" (38 mm) to 7 1/2" (191 mm). The SV4.5LA is fitted with a locking inclined channel end (identical to a normal vent section component) and a plain end with 3 pilot holes. Slip the plain end over the locking channel end of a standard SV4.5 vent component the required distance and secure with three screws. **Maintain a minimum 1" (25 mm) clearance to combustible materials for all vertical elements. Clearances for all horizontal elements are 3" (76 mm) on top, 1" (25 mm) on sides and 1" (25 mm) on the bottom.**

A. Frame ceiling opening - Use a plumb line from the ceiling above the appliance to locate center of the vertical run. Cut and/or frame an opening, 10 1/2" x 10 1/2" (267mm x 267mm) inside dimensions, about this center mark (**Figure 18**).

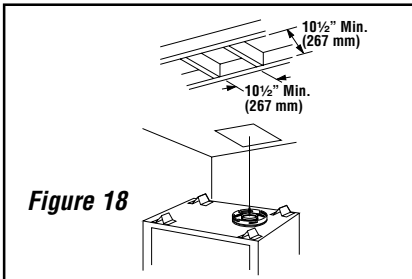

B. Attach vent components to appliance - Secure Vent SV4.5 direct vent system components are unitized concentric pipe components featuring positive twist lock connections (see **Figure 19**). All of the appliances covered in this document are fitted with collars having locking inclined channels. The dimpled end of the vent components fit over the appliance collar to create the positive twist lock connection.

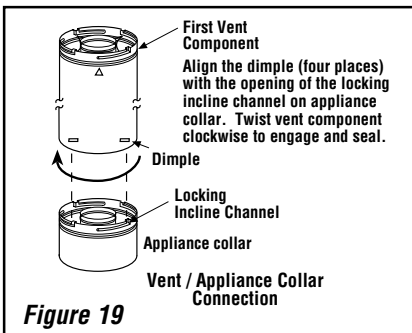

To attach a vent component to the appliance collar, align the dimpled end over the collar, adjusting the radial alignment until the four locking dimples are aligned with the inlet of the four inclined channels on the collar (refer to **Figure 23**). Push the vent component against the collar until it fully engages, then twist the component clockwise, running the dimples down and along the incline channels until they seat at the end of the channels.

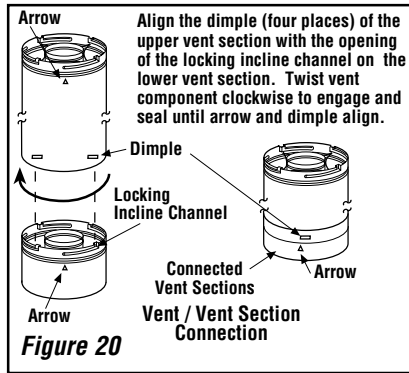

The unitized design of the **Secure Vent** components will engage and seal both the inner and outer pipe elements with the same procedure. Sealant and securing screws are not required.

C. Attach vent components to each other - Other vent sections may be added to the previously installed section in accordance with the requirements of the vertical vent figures and tables. To add another vent component to a length of vent run, align the dimpled end over the inclined channel end of the previously installed section, adjusting the radial alignment until the four locking dimples are aligned with the inlets of the four incline channels of the previous section. Push the vent component against the previous section until it fully engages, then twist the component clockwise running the dimples down and along the incline channels until they seat at the end of the channels. **This seating position is indicated by the alignment of the arrow and dimple as shown in Figure 20.**

D1. Install firestop/spacer at ceiling between stories - Install a firestop/spacer (catalog no. 96K87 - Secure Vent; catalog no.19M41 - Secure Flex) at the bottom side of the ceiling to the ceiling joists. Route the vent sections through the framed opening and secure the firestop/spacer with appropriate fasteners at each corner.

Remember to maintain 1" (25 mm) clearance between vertical chimney sections and combustibles, framing members, and attic or ceiling insulation.

D2. Install firestop thimble at the ceiling to roof location - Position appropriate firestop thimble (see **thimble table on page 24**) at the bottom side of ceiling and secure temporarily with two appropriate fasteners. Attach permanently, using at least two more fasteners, after vent sections have been assembled through the firestop thimble and after any necessary adjustments have been made.

Ensure the thimble penetrates the roof opening. The thimble must extend completely through the ceiling or roof cavity to the outermost plane of the roof. Use thimble extension SVTE26 when the distance between the outside of the roof and the inside of the ceiling exceeds the height of the firestop thimble. The thimble provides for zero clearances to combustibles and must be used at the ceiling/roof in manufactured homes with Secure Vent double wall vent sections. **Maintain 1 in. (25.4 mm) clearance between the thimble and the outer pipe of the secure vent chimney system.** See **Figure 21** for pitched roofs or flat roofs with flat ceilings or **Figure 22** for pitched roofs with cathedral ceilings.

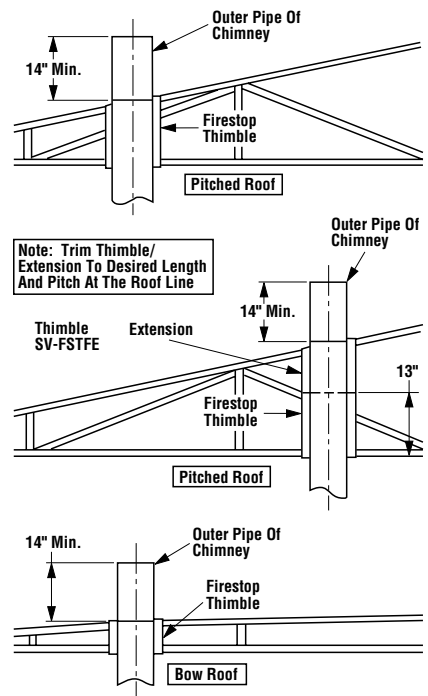

FIGURE 21

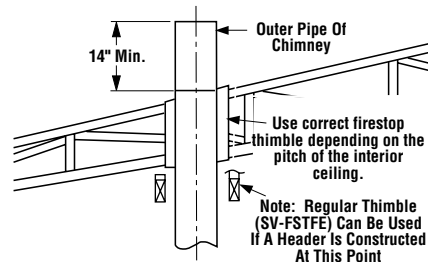

FIGURE 22

E. Support the vertical vent run sections -

Note - Proper venting support is very important. The weight of the vent must not be supported by the fireplace in any degree.

Support the vertical portion of the venting system every 8 feet (2.4m) above the fireplace vent outlet. One method of support is by utilizing field provided support straps (conventional plumber's tape). Secure the plumber's tape to the framing members with nails or screws. Loop the tape around the vent, securing the ends of the tape to the framing. The tape must not be secured directly with a fastener into the vent pipe. See **Figure 23**.

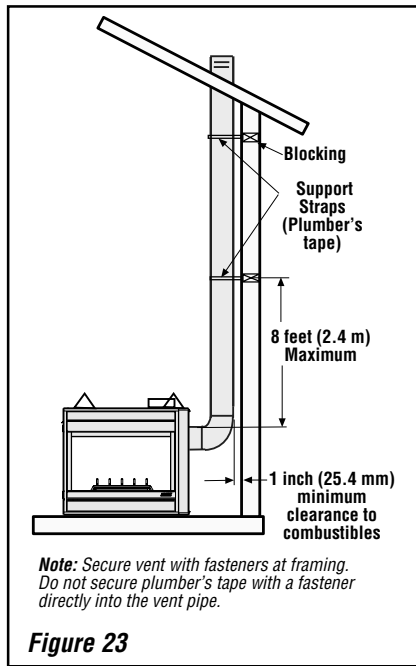

Figure 23

F. Change vent direction to horizontal/inclined run -

At transition from or to a horizontal/inclined run, install the SV4.5E45 and SV4.5E90 elbows in the same manner as the straight vent sections. The elbows feature a twist section to allow them to be routed about the center axis of their initial collar section to align with the required direction of the next vent run element. **Twist elbow sections in a clockwise direction only so as to avoid the possibility of unlocking any of the previously connected vent sections.** See **Figure 24**.

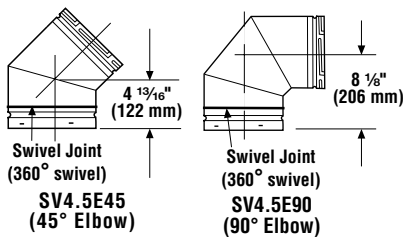

Figure 24

G. Continue installation of horizontal/inclined sections -

Continue with the installation of the straight vent sections in horizontal/inclined run as described in **Step C**. Install support straps every 5 ft. (1.52 m) along horizontal/inclined vent runs using conventional plumber's tape. See **page 15, Figure 34**. It is very important that the horizontal/inclined run be maintained in a straight (no dips) and slightly elevated plane in a direction away from the fireplace 1/4" per foot (20 mm per meter) of horizontal vent. Use a carpenter's level to measure from a constant surface and adjust the support straps as necessary.

It is important to maintain the required clearances to combustibles: 1" (25 mm) at all sides for all vertical runs; and 3" (76 mm) at the top, 1" (25 mm) at sides, and 1" (25 mm) at the bottom for all horizontal/inclined runs.

H. Frame roof opening - Identify location for vent at the roof. Cut and/or frame opening per Roof Framing Chart and **Figure 25**.

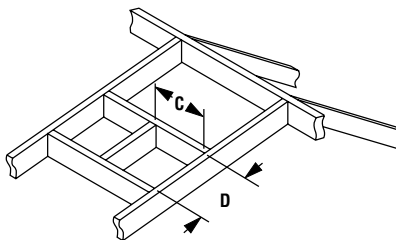

Framing Dimensions for Roof

| Pitch | C | D |
|-------|------------------|-------------------|
| 0/12 | 10½ in. (267 mm) | 10½ in. (267 mm) |
| 6/12 | 10½ in. (267 mm) | 12 in. (305 mm) |
| 12/12 | 10½ in. (267 mm) | 17 ¾ in. (451 mm) |

Figure 25

I. Install the roof flashing -

Extend the vent sections through the roof structure. Install the roof flashing over the vent section and position such that the vent column rises vertically (use carpenter's level) (**Figure 26**). Nail along perimeter to secure flashing or adjust roofing to overlap the flashing edges at top and sides only and trim where necessary. Seal the top and both sides of the flashing with waterproof caulking.

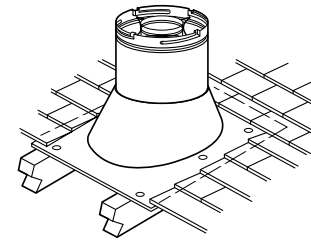

Figure 26

J. Install the storm collar - Install the storm collar, supplied with the flashing, over the vent/flashing joint. See **Figure 27**. Loosen the storm collar screw. Slide collar down until it meets the top of the flashing. Tighten the adjusting screw. Apply non-combustible caulking or mastic around the circumference of the joint to provide a water tight seal.

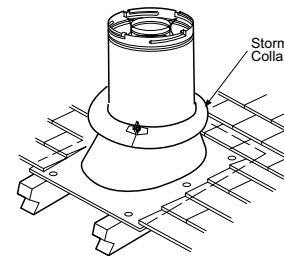

Figure 27

K. Install the vertical termination -

The final step involves installation of the SV4.5VTR Vertical Termination. Extend the vent sections to the height as shown in the "Vertical vent termination section" on **page 4**. The SV4.5VTR Vertical Termination (**Figure 28**) can be installed in the exact same fashion as any other **Secure Vent** section. Align the termination over the end of the previously installed section, adjusting the radial alignment until the four locking dimples of the termination are aligned with the inlets of the four incline channels of the last vent section. Push the termination down until it fully engages, then twist the termination clockwise running the dimples down and along the incline channels until they are seated at the end of the channels.

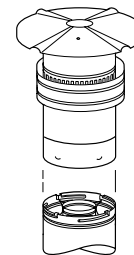

Figure 28

If the vent system extends more than 5' (1.5 m) above the roof flashing, stabilizers may be necessary. Additional screws may be used at section joints for added stability. Guide wires may be attached to the joint for additional support on multiple joint configurations.

VERTICAL VENT FIGURES/TABLES

Note: *Secure Vent* (rigid vent pipe) is shown in the figures; *Secure Flex* (flexible vent pipe) may also be used (see page 21).

WARNING:
UNDER NO CIRCUMSTANCES MAY SEPARATE SECTIONS OF CONCENTRIC FLEXIBLE VENT PIPE BE JOINED TOGETHER.

Note: It is very important that the horizontal/inclined run be maintained in a straight (no dips) and slightly elevated plane in a direction away from the fireplace of 1/4" rise per foot (20 mm per meter) of horizontal vent.

Note: SV4.5BF (*Secure Vent*), SF4.5BF (*Secure Flex*) firestop/spacer must be used anytime vent pipe passes through a combustible floor or ceiling. Use one of the thimbles shown on page 24 for roof penetrations as described on page 11. SV4.5HF (*Secure Vent*), SF4.5HF (*Secure Flex*) firestop/spacer must be used anytime vent pipe passes through a combustible wall.

Note: Two 45 degree elbows may be used in place of one 90 degree elbow. The same rise to run ratios, as shown in the venting figures for 90 elbows, must be followed if 45 degree elbows are used.

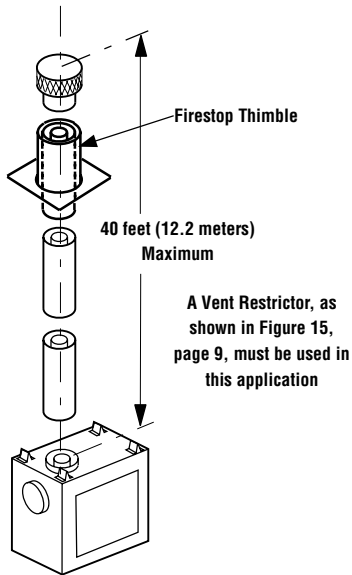

Figure 29 - Top Vent - STRAIGHT

TABLE A

| V MINIMUM | | H Maximum | |
|-----------|---------|-----------|---------|
| feet | (m) | feet | (m) |
| 1 | (0.305) | 2 | (0.61) |
| 2 | (0.61) | 4 | (1.222) |
| 3 | (0.914) | 6 | (1.86) |
| 4 | (1.22) | 8 | (2.4) |

V + H = 40 feet (12.4 m) Max.
 H = 8 feet (2.4 m) Max.

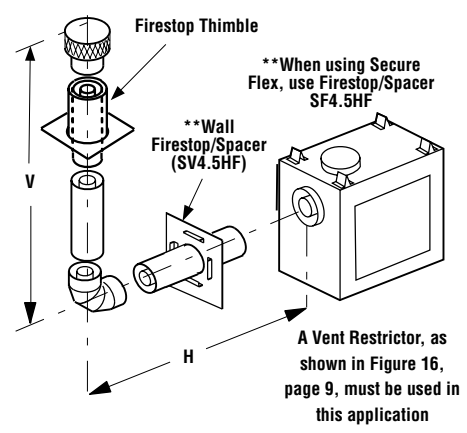

Figure 30 - Rear Vent - ONE 90 DEGREE ELBOW

TABLE B

| V MINIMUM | | H Maximum | |
|-----------|----------|-----------|----------|
| feet | (meters) | feet | (meters) |
| 1 | (0.305) | 5 | (1.52) |
| 2 | (0.610) | 10 | (3.1) |
| 3 | (0.914) | 15 | (4.65) |
| 4 | (1.22) | 20 | (6.2) |

V + V₁ + H = 40 feet (12.4 m) Max.
 H = 20 feet (6.2 m) Max.

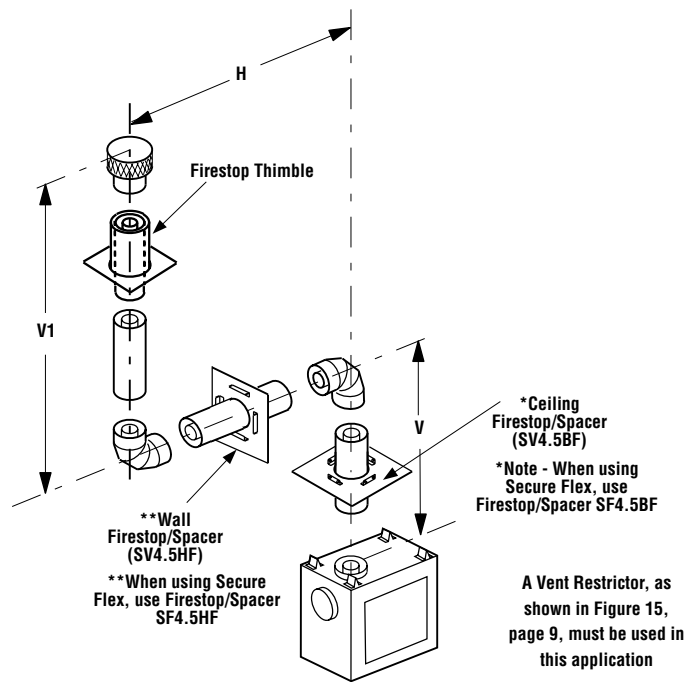

Figure 31 - Top Vent - TWO 90 DEGREE ELBOWS

VERTICAL VENT FIGURES/TABLES
(continued)

| TABLE D | | | | | |
|---|---------|-----------|---------|--------------------------|--------|
| V Minimum | | H Maximum | | H+H ₁ Maximum | |
| feet | (m) | feet | (m) | feet | (m) |
| 1 | (0.305) | 2 | (0.610) | 5 | (1.52) |
| 2 | (0.610) | 4 | (1.22) | 10 | (3.1) |
| 3 | (0.914) | 6 | (1.86) | 15 | (4.65) |
| 4 | (1.22) | 8 | (2.48) | 20 | (6.2) |
| V+V ₁ +H+H ₁ = 40 feet (12.4 m) Max. H = 8 feet (2.48 m) Max. H + H ₁ = 20 feet (6.2 m) Max. | | | | | |

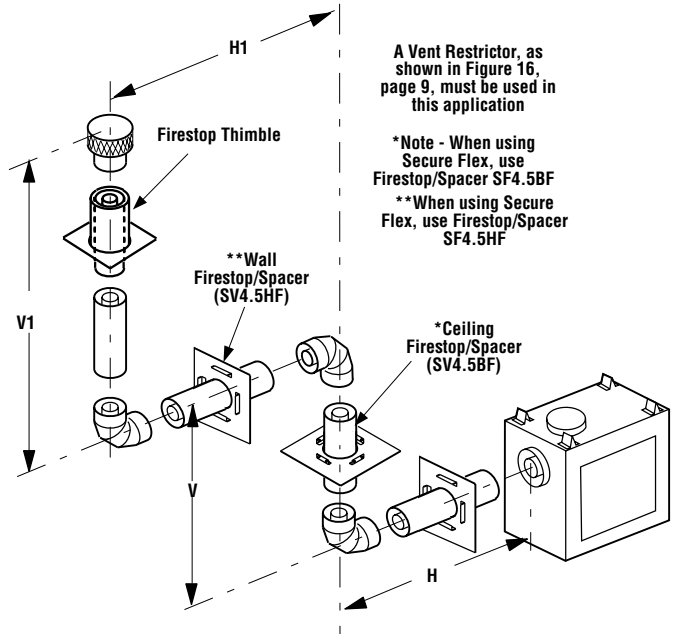

Figure 32 - Rear Vent - THREE ELBOWS

| TABLE E | | | |
|---|---------|----------------------------|--------|
| V MINIMUM | | H + H ₁ Maximum | |
| feet | (m) | feet | (m) |
| 1 | (0.305) | 5 | (1.52) |
| 2 | (0.610) | 10 | (3.1) |
| 3 | (0.914) | 15 | (4.65) |
| 4 | (1.22) | 20 | (6.2) |
| H + H ₁ = 20 feet (6.2 m) Max. V+V ₁ +H+H ₁ = 40 feet (12.4 m) Max. | | | |

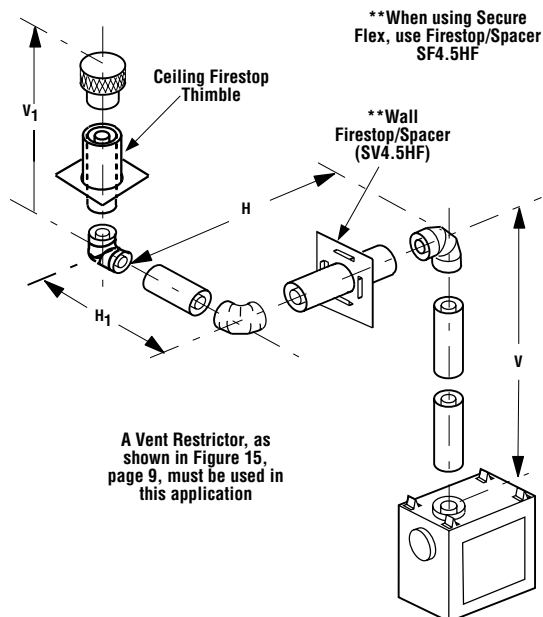

Figure 33 - Top Vent - THREE ELBOWS

HORIZONTAL (OUTSIDE WALL) TERMINATION SYSTEM

Figure 34, and Figures 38 to 44 on page 17 to 19 and their associated Horizontal Vent Table illustrate the horizontal venting configurations that are allowed to be used with these appliances. **Secure Vent** pipe applications are shown in these figures; **Secure Flex** pipe may also be used. **See page 20.** A Horizontal Vent Table summarizes each system's minimum and maximum vertical and horizontal length values that can be used to design and install the vent components in a variety of applications.

Both of these horizontal vent systems terminate through an outside wall. Building Codes limit or prohibit terminating in specific areas. Refer to **Figure 8 on page 6** for location guidelines.

Secure Vent SV4.5 direct vent system components are unitized concentric pipe components featuring positive twist lock connection, (refer to **Figure 19 on page 11**). All of the appliances covered in this document are fitted with collars having locking inclined channels. The dimpled end of the vent components fit over the appliance collar to create the positive twist lock connection.

A. Plan the vent run -

Analyze the vent routing and determine the types and quantities of sections required. 4 1/2" (114 mm), 10 1/2" (267 mm), 22 1/2" (572 mm), 34 1/2" (876 mm) and 46 1/2" (1181 mm) net section lengths are available. Plan the vent lengths so that a section joint does not occur within the space defined by ceiling joists, roof rafters or wall studs. Make allowances for elbows as indicated in **Figure 27 on page 12**.

Maintain a minimum 1" (25 mm) clearance to combustibles on the vertical sections. Clearances for the horizontal runs are: 3" (76 mm) on top, 1" (25 mm) on sides, and 1" (25 mm) at the bottom.

B. Frame exterior wall opening -

Locate the center of the vent outlet on the exterior wall according to the dimensions shown in **Figures 9 (DMSTNM-2), 10 (DMPFNM-2)** on page 7.

Cut and/or frame an opening, 10 1/2" x 12 1/8" (267 mm x 308 mm) inside dimensions, about this center.

C. Frame ceiling opening -

If the vertical route is to penetrate a ceiling, use plumb line to locate the center above the appliance. Cut and/or frame an opening, 10 1/2" x 10 1/2" (267 mm x 267 mm) inside dimensions, about this center (refer to **Figure 18 on page 11**).

D. Attach vent components to appliance -

To attach a vent component to the appliance collar, align the dimpled end over the collar, adjusting the radial alignment until the four locking dimples are aligned with the inlets of the four incline channels on the collar (refer to **Figure 19 on page 11**).

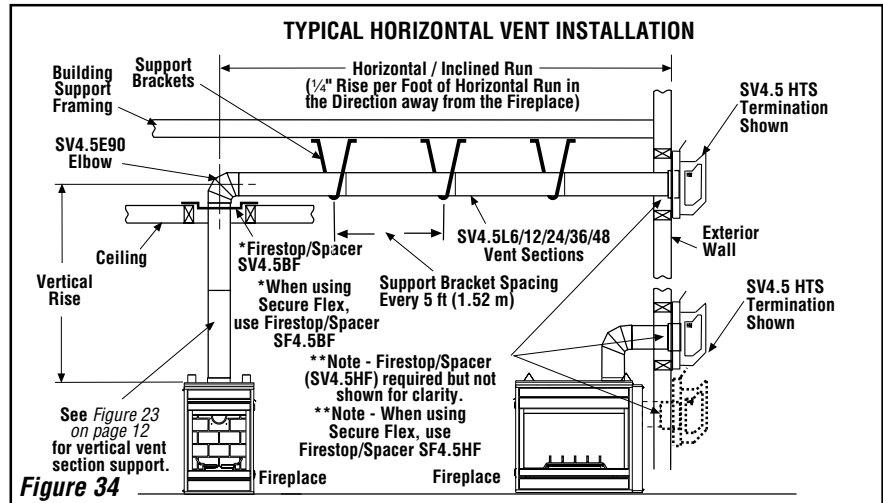

Push the vent component against the collar until it fully engages, then twist the component clockwise, running the dimples down and along the incline channels until they seat at the end of the channels. The unitized design of the **Secure Vent** components will engage and seal both the inner and outer pipe elements with the same procedure. Sealant and securing screws are not required.

E. Attach vent components to each other -

Other vent sections may be added to the previously installed section in accordance with the requirements of the vent tables. To add another vent component to a length of vent run, align the dimpled end of the component over the inclined channel end of the previously installed section, adjusting the radial alignment until the four locking dimples are aligned with the inlets of the four incline channels of the previous section. Push the vent component against the previous section until it fully engages, then twist the component clockwise running the dimples down and along the incline channels until they seat at the end of the channels. **This seating position is indicated by the alignment of the arrow and dimple as shown in Figure 20 on page 11.**

F. Install firestop/spacer at ceiling between stories -

Install a firestop/spacer (catalog no. 96K87 - Secure Vent; catalog no. 19M41 - Secure Flex) at the bottom side of the ceiling to the ceiling joists. Route the vent sections through the framed opening and secure the firestop/spacer with appropriate fasteners at each corner.

Remember to maintain 1" (25 mm) clearance to combustibles, framing members, and attic or ceiling insulation when running vertical chimney sections. Attic insulation shield (96K94) may be used to obtain the required clearances indicated here. See installation accessories table on page 27.

G. Support the vertical run sections - See section E on page 12.

H. Change vent direction - At transition from or to a horizontal/inclined run, install the SV4.5E45 and SV4.5E90 elbows in the same manner as the straight vent sections. The elbows feature a twist section to allow them to be routed about the center axis of their initial collar section to align with the required direction of the next vent run element. **Twist elbow sections in a clockwise direction only so as to avoid the possibility of unlocking any of the previously connected vent sections.** See **Figure 24 on page 11**.

I. Continue installation of horizontal/inclined sections -

Continue with the installation of the straight vent sections in horizontal/inclined run as described in **Step E**. Install support straps every 5 ft. (1.52 m) along horizontal/inclined vent runs using conventional plumber's tape. See **Figure 34**. It is very important that the horizontal/inclined run be maintained in a straight (no dips) and slightly elevated plane in a direction away from the fireplace of 1/4" rise per foot (20 mm per meter) of horizontal vent. Use a carpenter's level to measure from a constant surface and adjust the support straps as necessary.

It is important to maintain the required clearances to combustibles: 1" (25 mm) at all sides for all vertical runs; and 3" (76 mm) at the top, 1" (25 mm) at sides, and 1" (25 mm) at the bottom for all horizontal/inclined runs

J. Assemble vent run to exterior wall - If not previously measured, locate the center of the vent at the exterior wall. Prepare an opening as described in **Step B**. Assemble the vent system to point where the terminus of the last section is within 7½ in. (191 mm) to 11¼ in. (298 mm) inboard of the exterior surface to which the SV4.5 HTS termination is to be attached, see **Figure 36**. If the terminus of the last section is not within this distance, use the **telescopic vent section SV4.5LA**, as the last vent section. For wall thicknesses greater than that shown in **Figure 35**, refer to **table 3 on page 18**. This table lists the additional venting components needed (in addition to the termination and adapter) for a particular range of wall thicknesses.

K. Attach termination adapter - Attach the adapter (adapter - SV4.5RCH - provided with the termination) to the vent section or telescoping vent section, elbow or appliance collar as shown in **Figure 35** in the same manner as any SV4.5 vent component (refer to **Step E**).

L. Install Firestop/Spacer at exterior wall - When using the **square** termination, install SV4.5HF (Secure Vent), SF4.5HF (Secure Flex) Firestop/Spacer over the opening at the exterior side of the framing, long side up, with the 3 inch spacer clearance at the top as shown in **Figure 35**, and nail into place. (The Firestop/Spacer may also be installed over the opening at the interior side of the framing.) When using the **round** termination, a separate firestop/spacer is not required since this termination has integral spacers which provide the same function as a separate firestop/spacer.

M. Install the desired termination - See the horizontal venting figures for application restrictions on the round termination (SV4.5HTR).

1. Install the square termination (SV4.5HTS)- For the last step, from outside the exterior wall, slide the collars of the termination onto the adapter until the termination seats against the exterior wall surface to which it will be attached. Orient the housing of the termination with the arrow pointed upwards. Secure the termination to the exterior wall. **The horizontal termination must not be recessed into the exterior wall or siding** by more than the 1¼" (32 mm) as shown in **Figure 34**.

2. Install the round termination (SV4.5HTR) - See **Figure 37** for an illustration of the round termination. For the last step, from outside the exterior wall, slide the collars of the termination onto the adapter (the outer over the outer and the inner inside the inner) until the termination seats against the exterior wall surface to which it will be attached.

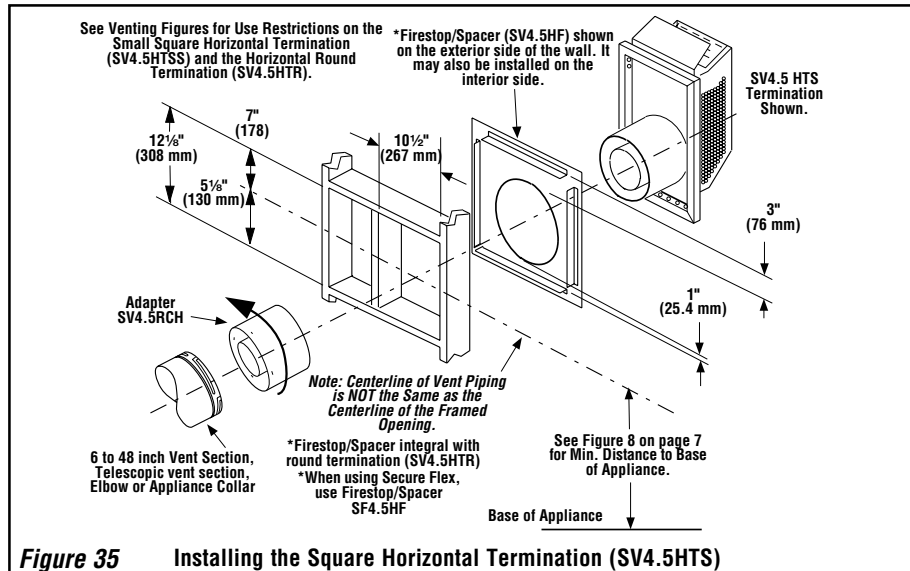

Figure 35 Installing the Square Horizontal Termination (SV4.5HTS)

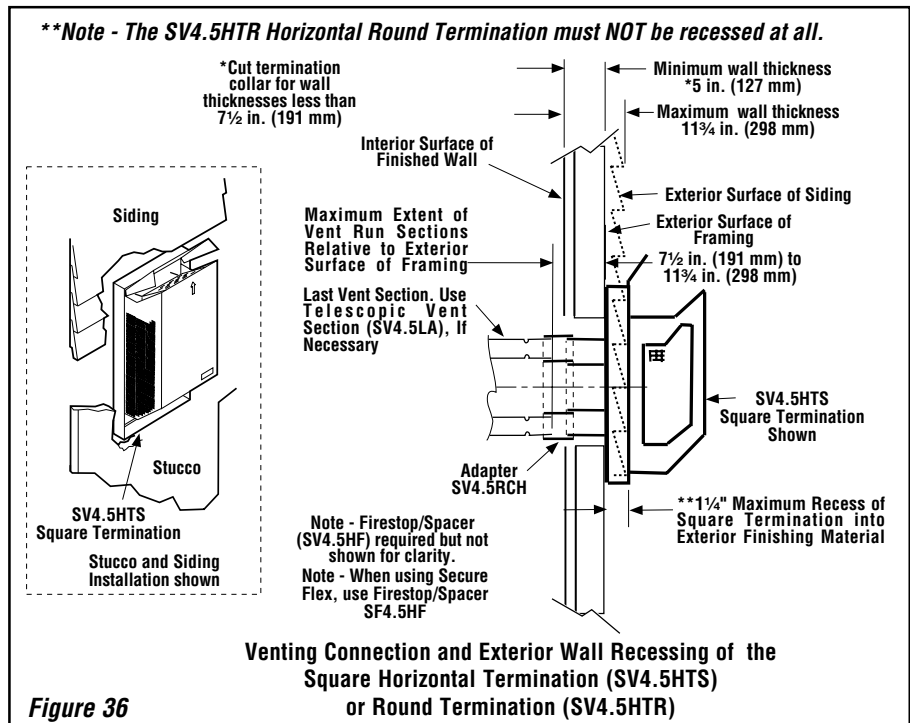

Figure 36

Orient the housing of the termination with the arrow pointed upwards. Secure the termination to the exterior wall. **The SV4.5HTR Round Termination may not be used when the appliance is vented directly out the wall from the side as shown in Figure 36. Do Not recess the SV4.5HTR round termination at all.**

SFHRK Snorkel Cap -The snorkel cap is designed to be fitted into a basement window box. The SFHRK cap is for use with flex vent pipe. Vertical distance between the inlet and outlet of the cap is 28 in. (711 mm).

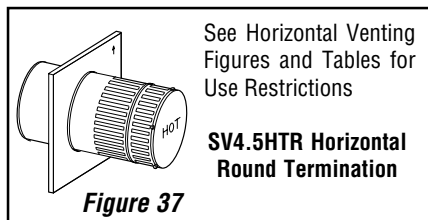

Figure 37

NOTE: DIAGRAMS & ILLUSTRATIONS NOT TO SCALE.

HORIZONTAL VENT FIGURES/TABLES

Note: *Secure Vent* components (rigid vent pipe and terminal) are shown in the figures; *Secure Flex* components (flexible vent pipe and terminal) may also be used.

Note: Two 45 degree elbows may be used in place of one 90 degree elbow. The same rise to run ratios, as shown in the venting figures for 90 elbows, must be followed if 45 degree elbows are used.

Note: It is very important that the horizontal/inclined run be maintained in a straight (no dips) and slightly elevated plane in a direction away from the fireplace of 1/4" rise per foot (20 mm per meter) of horizontal vent.

Note: SV4.5BF (*Secure Vent*), SF4.5BF (*Secure Flex*) firestop/spacer must be used anytime vent pipe passes through a combustible floor or ceiling. SV4.5HF (*Secure Vent*), SF4.5HF (*Secure Flex*) firestop/spacer must be used anytime vent pipe passes through a combustible wall.

WARNING:
UNDER NO CIRCUMSTANCES MAY SEPARATE SECTIONS OF CONCENTRIC FLEXIBLE VENT PIPE BE JOINED TOGETHER.

TABLE 3 - Venting Components Required for Various Exterior Wall Thicknesses, When Using Any of These Termination Kits - Square Termination (SV4.5HTS) Round Termination (SV4.5HTR)

| Venting Components Required | Exterior Wall Thicknesses inches (mm) |
|---|---------------------------------------|
| Termination Kit Only | 7½ to 11¼ (191 to 298) |
| Termination Kit and 6 in. vent section (SV4.5L6) | 11¼ to 16½ (298 to 419) |
| Termination Kit and 12 in. vent section (SV4.5L12) | 18¼ to *22¼ (464 to *565) |
| Termination Kit and Telescopic section (SV4.5LA) and 6 in. vent section (SV4.5L6) | 13 to *23¼ (330 to *591) |

*Note: See **Figure 36** for wall thickness range reductions when using SV4.5HTS termination.

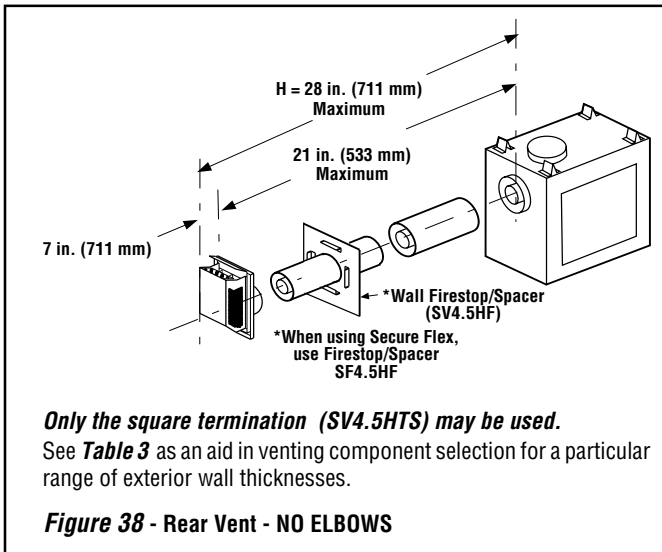
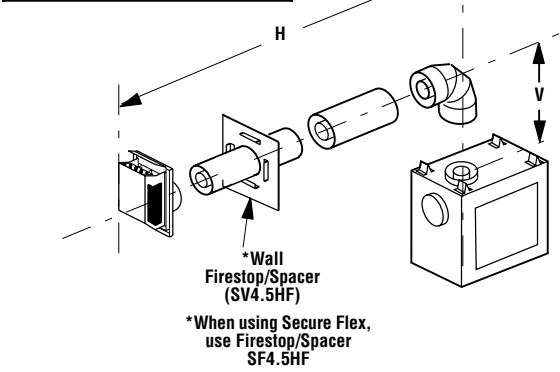

TABLE F
 V = One 90 degree elbow
 H = 3 feet (0.914 m) Max.



Square termination (SV4.5HTS) shown; Round Termination (SV4.5HTR) may also be used.

Figure 39 - Top Vent - ONE 90 DEGREE ELBOW - ELBOW CONNECTION AT APPLIANCE

TABLE G

| V Minimum | | H Maximum | |
|-----------|---------|-----------|--------|
| feet | (m) | feet | (m) |
| 1 | (0.305) | 5 | (1.52) |
| 2 | (0.61) | 10 | (3.1) |
| 3 | (0.914) | 15 | (4.65) |
| 4 | (1.22) | 20 | (6.2) |

V + H = 40 feet (12.4 m) Max.
 H = 20 feet (6.2 m) Max.

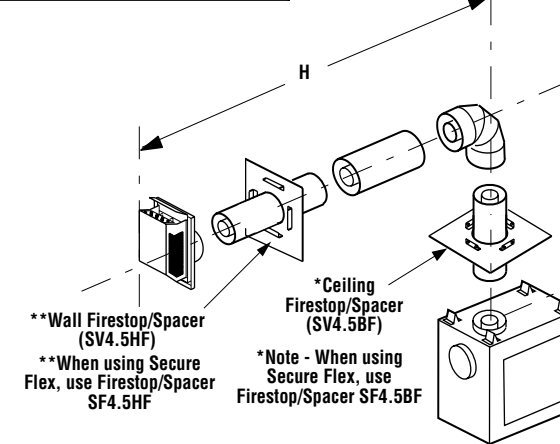

Square termination (SV4.5HTS) shown; Round Termination (SV4.5HTR) may also be used.

Figure 40 - Top Vent - ONE 90 DEGREE ELBOW - ELBOW CONNECTION NOT DIRECTLY AT APPLIANCE

HORIZONTAL VENT FIGURES/TABLES
(continued)

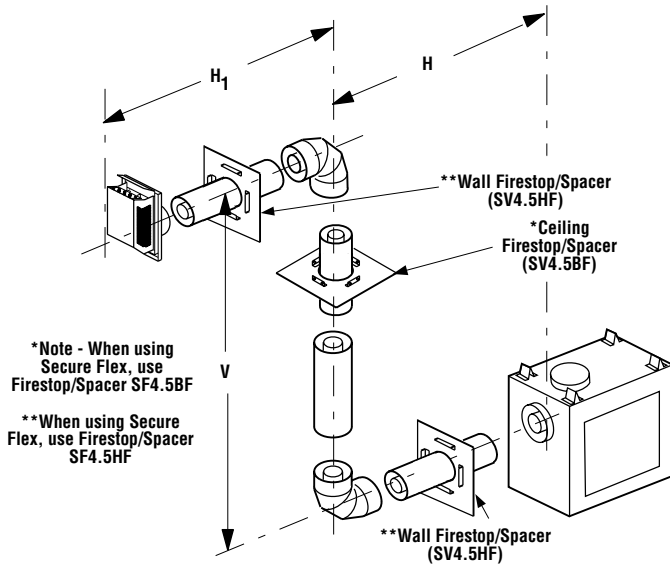

| V Minimum | | H Maximum | | H+H ₁ Maximum | |
|-----------|---------|-----------|---------|--------------------------|--------|
| feet | (m) | feet | (m) | feet | (m) |
| 1 | (0.305) | 2 | (0.610) | 5 | (1.52) |
| 2 | (0.610) | 4 | (1.22) | 10 | (3.1) |
| 3 | (0.914) | 6 | (1.86) | 15 | (4.65) |
| 4 | (1.22) | 8 | (2.48) | 20 | (6.2) |

V+H+H₁ = 40 feet (12.4 m) Max.
H = 8 feet (2.48 m) Max.
H + H₁ = 20 feet (6.2 m) Max.

See **Table 3** as an aid in venting component selection for a particular range of exterior wall thicknesses.

Square termination (SV4.5HTS) shown; Round Termination (SV4.5HTR) may also be used.

Figure 41 - Rear Vent - TWO 90 DEGREE ELBOWS

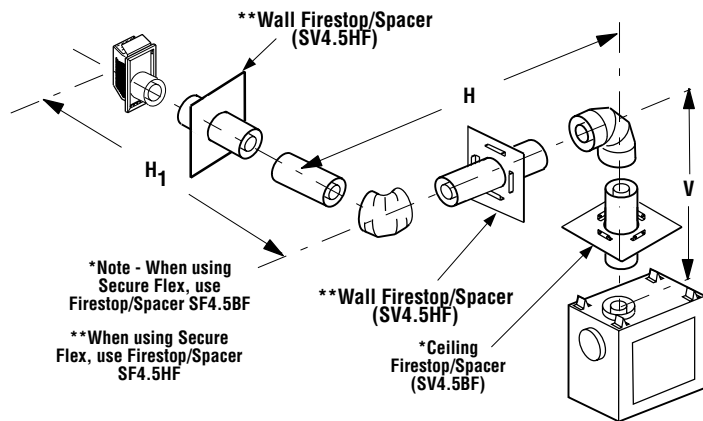

| V Minimum | | H + H ₁ Maximum | |
|-----------|---------|----------------------------|--------|
| feet | (m) | feet | (m) |
| 1 | (0.305) | 5 | (1.52) |
| 2 | (0.610) | 10 | (3.1) |
| 3 | (0.914) | 15 | (4.65) |
| 4 | (1.22) | 20 | (6.2) |

V + H + H₁ = 40 feet (12.4 m) Max.
H + H₁ = 20 feet (6.2 m) Max.

See **Table 3** as an aid in venting component selection for a particular range of exterior wall thicknesses.

Square termination (SV4.5HTS) shown; Round Termination (SV4.5HTR) may also be used.

Figure 42 - Top Vent - TWO 90 DEGREE ELBOWS

HORIZONTAL VENT FIGURES/TABLES
(continued)

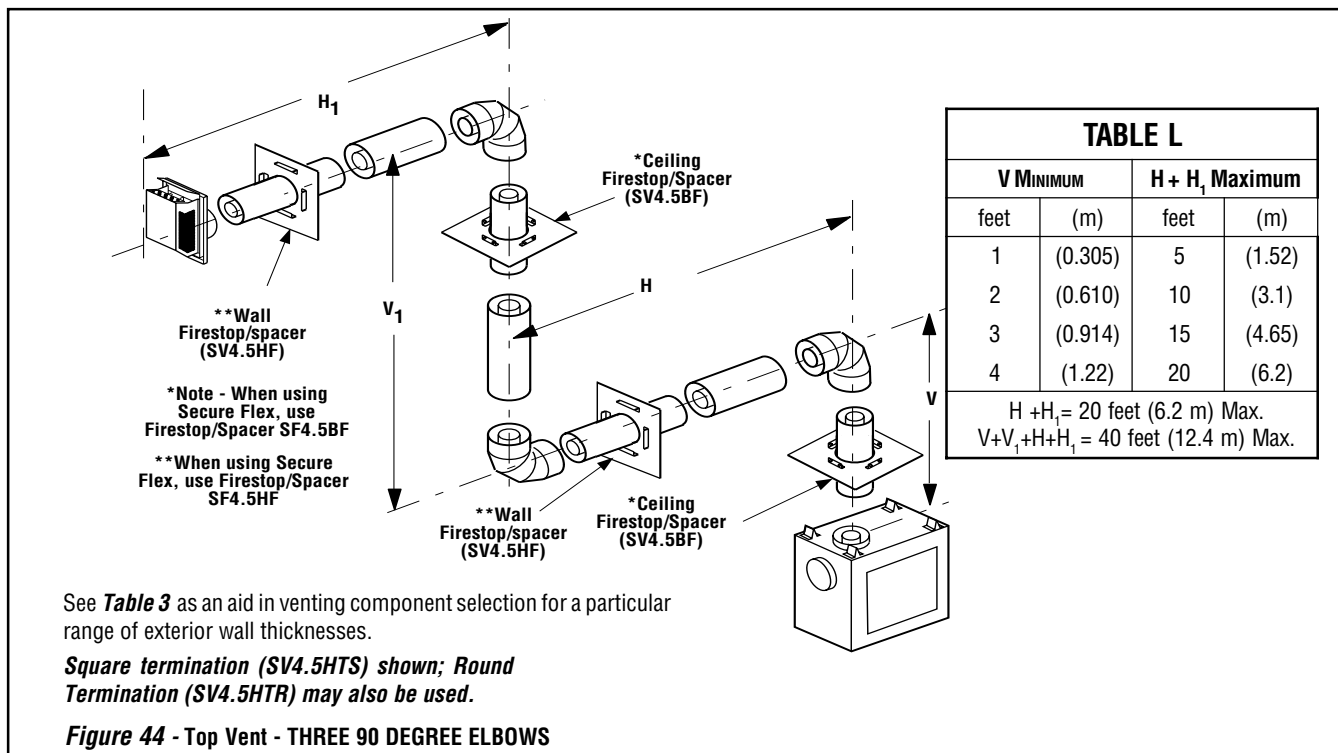
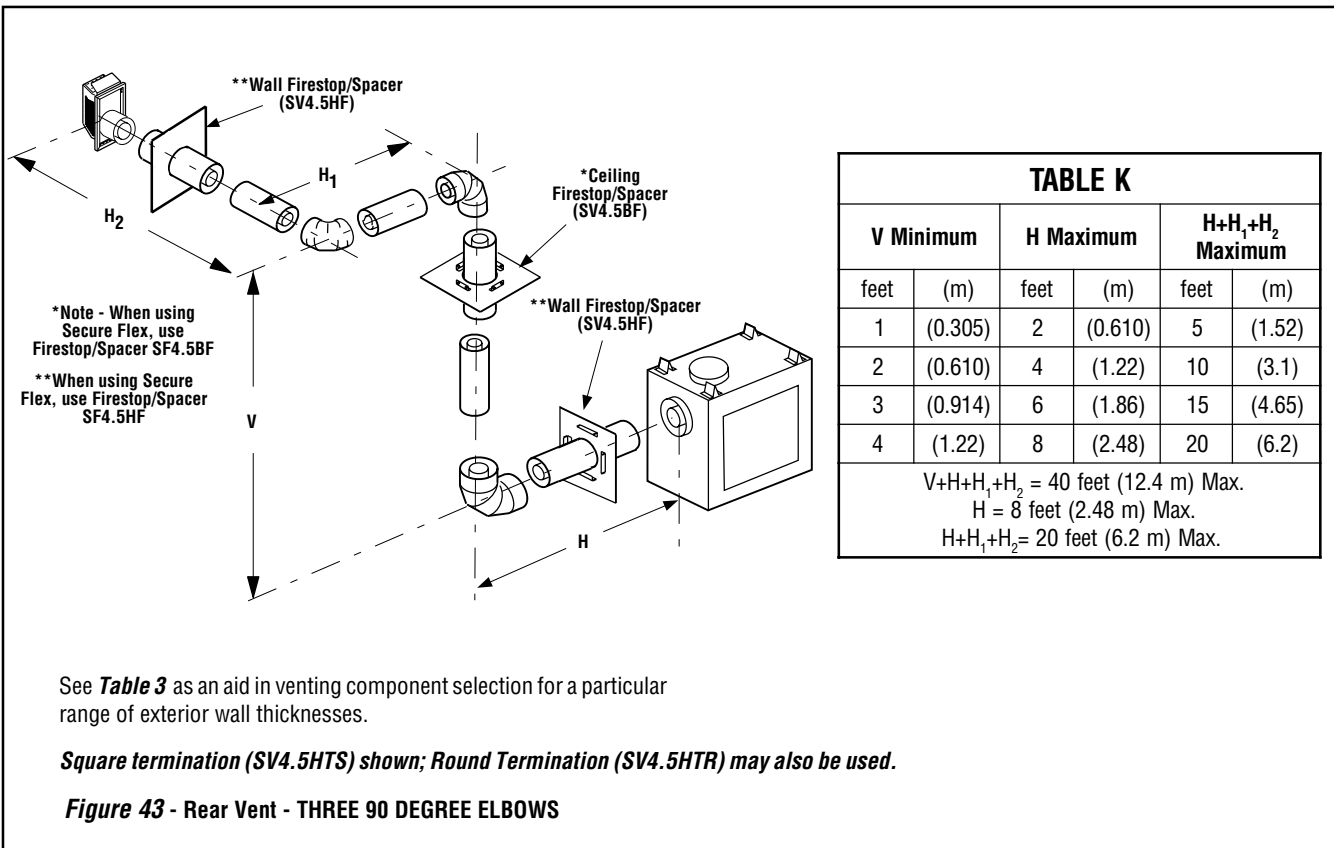

VERTICAL OR HORIZONTAL VENTING USING SECURE FLEX KITS AND COMPONENTS

Secure Flex venting kits and components may be used in any venting application in place of rigid **Secure Vent** (SV4.5) direct vent components. All restrictions, clearances and allowances that pertain to the rigid piping apply to the flexible venting. **Secure Flex kits may not be modified; also, under no circumstances may separate sections of flex pipe be joined together.**

Using adapter (SV4.5RF), **Secure Flex** kits may be added to the end of a vent run made up of rigid **Secure Vent** (SV4.5) vent sections provided that doing so does not violate any of the venting length, height, routing, horizontal to vertical ratio requirements or clearance considerations detailed in this manual.

Secure Flex kits come with an adapter that can be fitted to the inclined channel end of the last **Secure Vent** (SV4.5) vent section in a rigid system in the exact same fashion as any other **Secure Vent** section.

Align the dimpled end of the adapter over the previously installed section or appliance collar, adjusting the radial alignment until the four locking dimples of the adapter are aligned with the inlets of the four incline channels of the last vent section or collar. Push on the adapter until it fully engages, then twist the adapter clockwise running the dimples down and along the incline channels until they seat at the end of the channels.

Attach the flexible vent to the adapter as follows (see also Figure 45):

A. Install the Inner Flex Pipe -

1. Install the small gear clamp loosely around the inner flexible vent pipe, push it back out of the way.
2. Apply a bead of **Mill-Pac Black (700°F) high temperature sealant - Catalog No. 10K81** to the inner adapter collar, approximately ½ inch from the end.
3. Pull and extend the inner flexible vent pipe.
4. Slide the inner flex pipe over the adapter collar. Ensure the flexible vent pipe completely engages the adapter collar to a distance of 1¾ inches from the end, and that it is free from damage or tears.
5. Slide the gear clamp down and tighten it fully to secure the flexible vent to the adapter inner collar approximately ¾ inch from the end of the flex.
6. Install **three screws 120 degrees apart** through the flexible vent pipe and into the adapter collar just below the gear clamp to provide additional security to the connection.

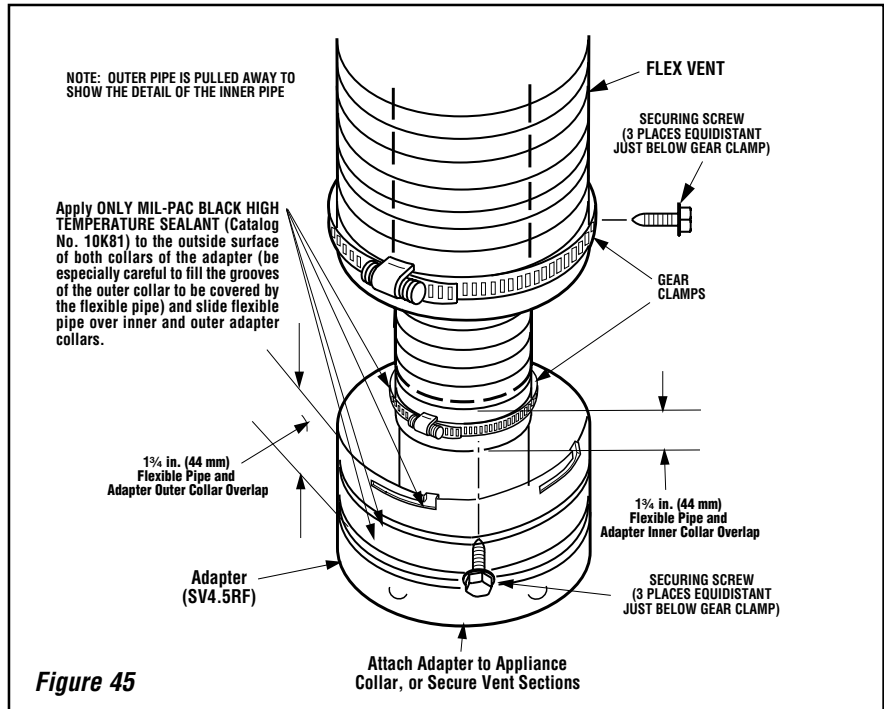

Figure 45

B. Install the Outer Flex Pipe -

1. Install the large gear clamp loosely around the outer flexible vent pipe, push it back out of the way.
2. Apply a bead of **Mill-Pac Black (700°F) high temperature sealant - Catalog No. 10K81** to the outer adapter collar; to the grooves of the collar which extend approximately 1 inch from the end and to the flat surface, approximately 1⅜ inches from the end.
3. Pull and extend the outer flexible vent pipe.
4. Slide the outer flex pipe over the adapter collar. Ensure the flexible vent pipe completely engages the adapter collar to a distance of 1¾ inches from the end, and that it is free from damage or tears.
5. Slide the gear clamp down and tighten it fully to secure the flexible vent to the adapter outer collar approximately ¾ inch from the end of the flex.
6. Install **three screws 120 degrees apart** through the flexible vent pipe and into the adapter collar just below the gear clamp to provide additional security to the connection.

C. Route Flex Vent -

Ensure that the flex vent is properly routed to provide the required clearance. **Do not** allow the flexible vent to bend in a radius tighter than 5" (127 mm). Refer to **Figure 46**. Space out the internal flex vent spacers evenly - approximately every 6 inches - and avoid kinking of inner pipe. Support horizontal sections of flex with metal straps at 2 foot (0.61m) intervals.

D. Install Firestop/Spacers at walls and Firestop Thimbles at ceilings and roofs -

When **Secure Flex** penetrates a wall use the SF4.5 HF firestop/spacer. See the appropriate sections and figures shown throughout the venting section for their installation requirements. When **Secure Flex** penetrates a ceiling or roof use the appropriate firestop thimble listed in the **Table on page 24** and described in **Figures 21 and 22 on page 11**.

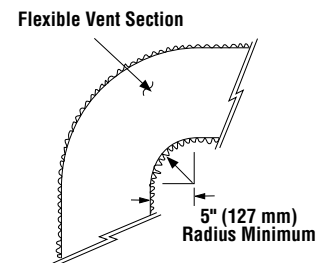

Figure 46

E. Attach Flex Vent to Termination -

Secure Flex components can be purchased separately and attached to bulk lengths of **Secure Flex** flexible tubing cut to size at the job site. Secure the flexible vent to the **Secure Flex** terminations in the same manner (see **Figure 45**) as it was attached to the adapter.

Note: *Secure Flex* vent must be attached to *Secure Flex* terminations only. DO NOT substitute *Secure Vent* terminations or the *Secure Vent* adapter for *Secure Flex* components. The collars of *Secure Flex* terminations and adapters have a different diameter than that used with the *Secure Vent* pipe. Additionally, *Secure Flex* components have an extended length center tube for use in attaching the flexible vent.

Step 4. MILLIVOLT CIRCUIT WIRING (Figure 47)

The gas valve is set in place and pre-wired at the factory.

1. Select any of the following optional controls: appliance-mounted (rocker switch) or wall-mounted switch, thermostat, or one of the optional remote control kits. If appliance-mounted ON/OFF control is selected, mount it in the gas valve mounting bracket.
2. If wall-mounted ON/OFF control or thermostat is selected mount it in a convenient location on a wall near the fireplace.
3. Wire the control within the millivolt control circuit using the 15 feet of 2 conductor wire supplied with the unit.
Caution: Do not connect the optional wall switch to a 120V power supply.
4. Alternatively, the appliance may be operated without the use of the controls indicated in step 1, solely by manipulating the gas valve control knob. In order to use this method, twist the free ends of the two conductor wire (located on top of the unit) together as shown in *Figure 47*.

Note: The supplied 15 feet of 2 conductor wire has one end of each conductor connected to the gas valve circuit and the other end of each conductor placed loose on top of the unit.

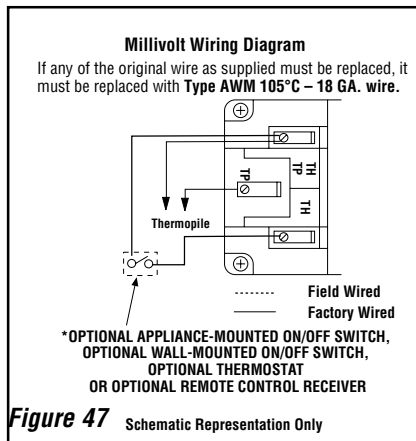

Figure 47 Schematic Representation Only

Step 5. CONNECTING GAS LINE

Make gas line connections. All codes require a shut-off valve mounted in the supply line. *Figure 48* illustrates two methods for connecting the gas supply. The flex-line method is acceptable in the U.S., however, Canadian requirements vary depending on locality. Installation must be in compliance with local codes.

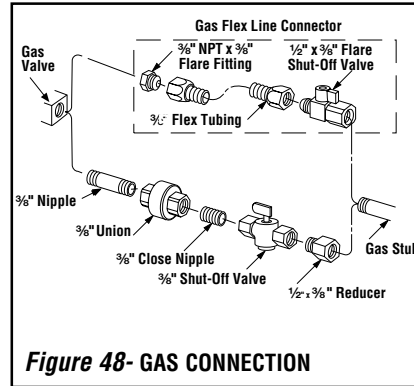

Figure 48- GAS CONNECTION

These appliances are equipped with a gas flex line for use (where permitted) in connecting the unit to the gas line. A gas flex line is provided to aid in attaching the direct vent appliance to the gas supply. The gas flex line can only be used where local codes permit. See *Figure 48* for flex line description. The flex line is rated for both natural and propane gas. A manual shut off valve is also provided with the flex line.

The gas control valve is located in the lower control compartment. To access the valve proceed as follows:

Open the control compartment access panel, (*Figure 49*) by actuating the spring-loaded magnetic catches securing the panel, gently depressing the outer top corners of the panel until the catches "pop" the panel free and allowing it to swing out and down to open.

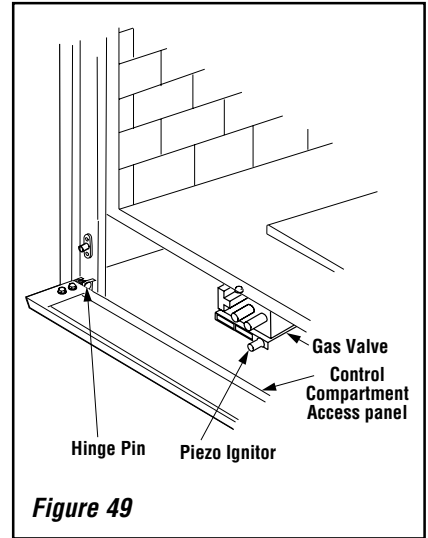

Figure 49

The millivolt control valve has a 3/8" (10 mm) NPT thread inlet port.

Secure all joints tightly using appropriate tools and sealing compounds (ensure propane resistant compounds are used in propane applications).

Turn on gas supply and test for gas leaks using a soapy water solution. **Never use an open flame to check for leaks.**

A. Mix a 50% dish soap, 50% water solution.

B. Light the appliance (refer to the lighting instructions provided in the Homeowner's Care and Operation Instructions).

C. Brush all joints and connections with the soapy water solution to check for leaks. If bubbles are formed, or gas odor is detected, turn the gas control knob to the "OFF" position. Either tighten or refasten the leaking connection and retest as described above.

D. When the gas lines are tested and leak free, observe the individual tongues of flame on the burner. Make sure all ports are open and producing flame evenly across the burner. If any ports are blocked, or partially blocked, clean out the ports.

Step 6. INSTALLING LOGS, VERMICULITE, DECORATIVE VOLCANIC STONE AND GLOWING EMBERS

The log set, with one plastic bag of vermiculite, is packaged in a carton located within the firebox. One plastic bag of glowing embers and one plastic bag of decorative volcanic stone is located in the bottom compartment. Refer to the **Homeowner's Care and Operating Instructions** for detailed placement instructions for the log set, vermiculite, decorative volcanic stone and glowing embers.

Step 7. CHECKING APPLIANCE OPERATION

With gas line installed, run initial system checkout before closing up the front of the unit. Follow the pilot lighting instructions provided in the Homeowner's Care and Operation Instructions. For piezo ignitor location see **Figure 49 on page 21** (millivolt appliances only).

Note: Lighting instructions may also be found on the pull out lighting instruction labels attached to the gas control valve. To access the label, see the procedure on the previous page described for accessing the gas control valve.

When first lighting the appliance, it will take a few minutes for the line to purge itself of air. Once purging is complete, the pilot and burner will light and operate as indicated in the instruction manual. Subsequent lightings of the appliance will not require such purging. Inspect the pilot flame (remove logs, if necessary, handling carefully).

Millivolt Appliance Checkout

The pilot flame should be steady and, not lifting or floating. Flame should be blue in color with traces of orange at the outer edge.

The top $\frac{3}{8}$ " (10 mm) at the pilot generator (thermopile) and the top $\frac{1}{8}$ " min (tip) of the quick drop out thermocouple should be engulfed in the pilot flame. The flame should project 1" (25 mm) beyond the hood at all three ports (**Figure 50**).

Replace logs after pilot inspection.

To light the burner; turn "ON" the unit-mounted or wall-mounted ON/OFF switch and rotate the gas valve control knob counterclockwise to the "ON" position.

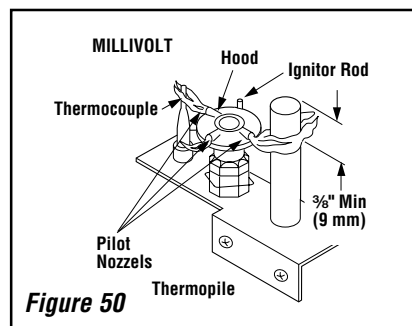
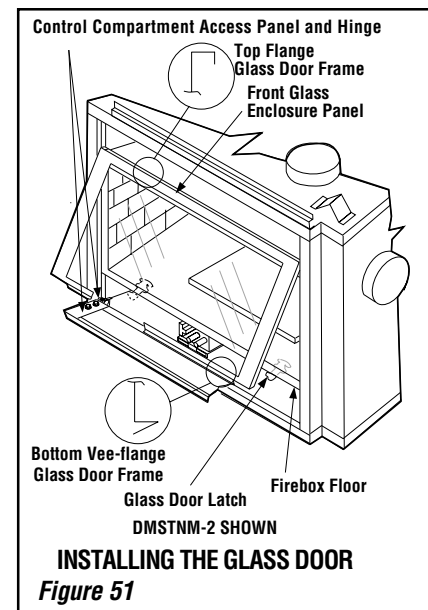

Figure 50

Step 8. INSTALLING GLASS ENCLOSURE PANELS

1. Visually inspect the gasket on the backside of the panels. The gasket surface must be clean, free of irregularities and seated firmly.
2. Position the glass enclosure panel in front of the firebox opening at a 45 degree angle and engage the top flange over the lip at the top of the firebox opening. **See Figure 51.**
3. Swing the glass enclosure panel down and back. Ensure the gasket seats evenly as the panel draws shut. Engage the Vee-flange at the bottom of the panel with the latches and close the latches to secure the panel.



WARNING: HANDLE THE GLASS WITH EXTREME CARE! TEMPERED GLASS IS SUSCEPTIBLE TO DAMAGE (SCRATCHES, FOR EXAMPLE) – HANDLE GLASS DOORS (GLASS ENCLOSURE PANELS) GENTLY WHILE REINSTALLING THEM.

WARNING: NEVER OPERATE THE APPLIANCE WITHOUT THE GLASS ENCLOSURE PANELS IN PLACE AND SECURE.

Step 9. BURNER ADJUSTMENTS

Flame Appearance and sooting

Proper flame appearance is a matter of taste. Generally, most people prefer the warm glow of a yellow to orange flame. Appliances operated with air shutter openings that are too large will exhibit flames that are blue and transparent. These weak, blue and transparent flames are termed anemic. If the air shutter opening is too small sooting may occur.

Sooting is indicated by black puffs developing at the tips of very long orange flames. Sooting results in black deposits forming on the logs, appliance inside surfaces and on exterior surfaces adjacent to the vent termination. Sooting is caused by incomplete combustion in the flames and lack of combustion air entering the air shutter opening. To achieve a warm yellow to orange flame with an orange body that does not soot, the shutter opening must be adjusted between these two extremes.

No smoke or soot should be present. Reposition the log set if flames impinge on any part of it. If the log set is properly positioned and sooting conditions exist, the air shutter opening on the main burner tube should be adjusted. Normally, the more offsets in the vent system, the greater the need for the air shutter to be opened further.

Burner Adjustment

WARNING: AIR SHUTTER ADJUSTMENT SHOULD ONLY BE PERFORMED BY A QUALIFIED PROFESSIONAL SERVICE TECHNICIAN.

IMPORTANT: ENSURE THAT THE GLASS ENCLOSURE PANELS ARE IN PLACE AND SEALED DURING ADJUSTMENT.

CAUTION: THE AIR SHUTTER DOOR AND NEARBY APPLIANCE SURFACES ARE HOT. EXERCISE CAUTION TO AVOID INJURY WHILE ADJUSTING FLAME APPEARANCE.

To adjust the flame, rotate the adjustment rod (located in the lower control area) counter-clockwise to increase or clockwise to reduce the air shutter opening. **Adjust the air shutter to the recommended setting as shown in Figure 52.** Allow the burner to operate for at least 15 minutes. Observe the flame continuously. If it appears weak or sooty as previously described, adjust the air shutter by rotating the adjustment rod until the flame appearance is as desired.

The adjustment rod and associated adjustable air shutter is patented technology. Flame adjustments can be made quickly and accurately to taste without the need of disassembling the appliance and waiting for 15 minutes after each adjustment.

Propane models may exhibit a flame pattern that may candle or appear stringy. If this is problematic or persists as the appliance is continually operated, adjust the air shutter closed as described in the previous paragraphs. Operate the appliance for a period of time as the effect diminishes, ensuring that the appliance does not develop sooty flames.

When you have verified that the appliance operates properly, proceed to finish the installation. Leave the control knob in the ON position and the remote switch OFF. Close the lower control compartment door.

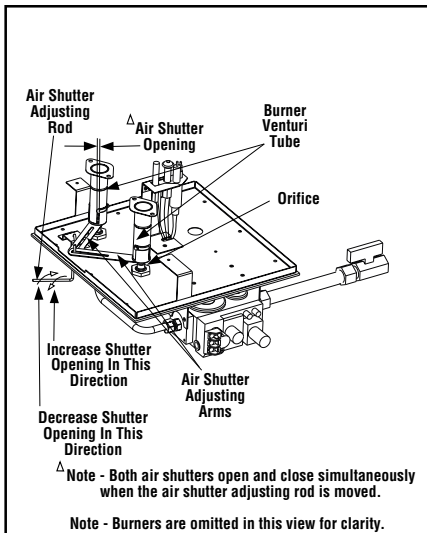

| ***MAIN BURNER FACTORY SHUTTER SETTING | | |
|---|-------------------------------|----------------------------------|
| Models | Natural Gas inches (mm) | Propane Gas inches (mm) |
| DMSTNM-2 | *TWO | **TWO |
| DMPFNM-2 | 1/8 (3) SLOTS | 1 1/16 (17) SLOTS |

Adjustment Rod Positions (when viewed from above):

*Natural Gas - **fully clockwise**

Propane - **fully counter clockwise

*** Settings are shown for each burner.

Figure 52

NOTE: DIAGRAMS & ILLUSTRATIONS NOT TO SCALE.

Step 10. HOOD INSTALLATION

All of these appliances must have hoods installed on all sides with glass enclosure panels prior to operating.

Slide the hoods into the slots on the lower edges of the radiant panels (**Figure 53**)

FINISHING REQUIREMENTS

Wall Details

Complete finished interior wall. To install the appliance facing flush with the finished wall, position framework to accommodate the thickness of the finished wall (**Figure 53**)

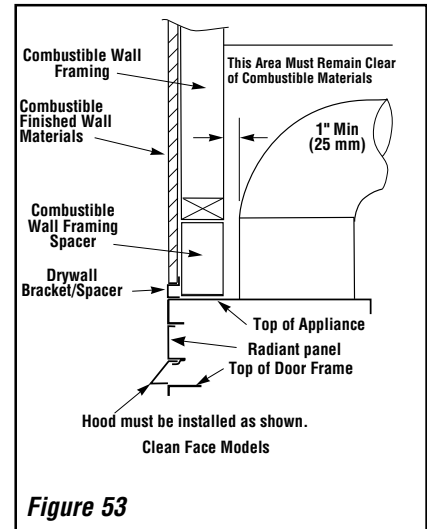

Figure 53

A hearth extension is not required with this appliance. If a hearth extension is used, do not block the control compartment access panel. Any hearth extension used is for appearance only and does not have to conform to standard hearth extension installation requirements.

Note: Combustible wall finish materials and/or surround materials must not be allowed to encroach the area defined by the appliance front face (black sheet metal). Never allow combustible materials to be positioned in front of or overlapping the appliance front face. See **Figure 53**.

Non-combustible materials, such as surrounds and other appliance trim, may be installed on the appliance front face with these exceptions: they must not cover any portion of the glass or louvers; they must not cover any portion of the top radiant panel and the air gaps surrounding the top radiant panel.

Vertical installation clearances to combustible mantels vary according to the depth of the mantel. See **Figure 54 on 24**. Mantels constructed of non-combustible materials may be installed at any height above the appliance opening; however, do not allow anything to hang below the hood.

COLD CLIMATE INSULATION

If you live in a cold climate, seal all cracks around your appliance with noncombustible material and wherever cold air could enter the room. It is especially important to insulate outside chase cavity between studs and under floor on which appliance rests, if floor is above ground level.

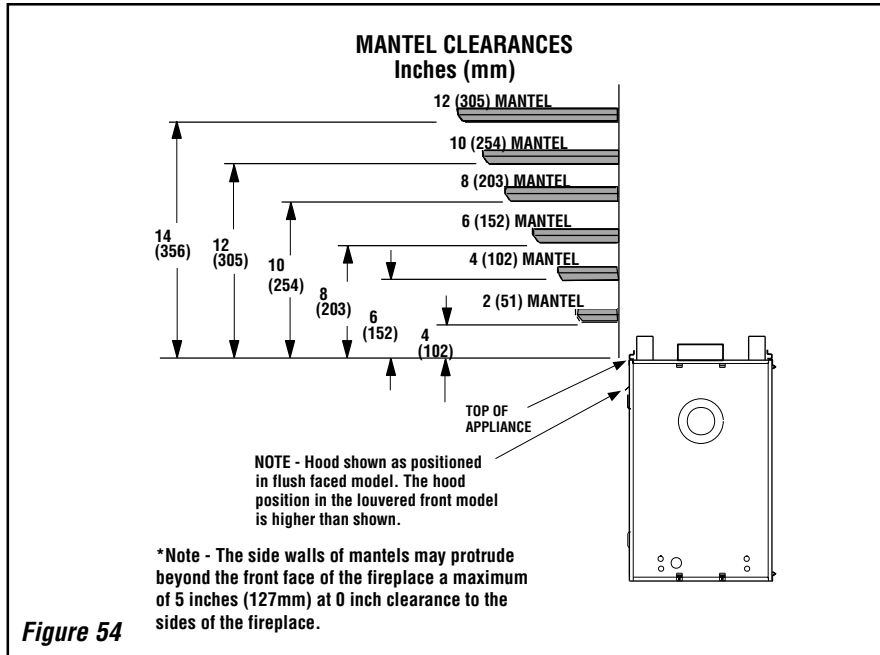









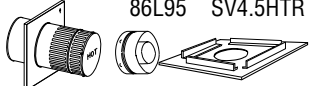
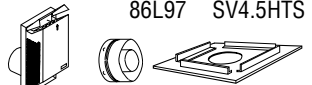



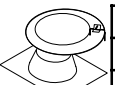

INSTALLATION ACCESSORIES

| Listed Secure Vent™ Components Unique to BDM35 Models | | | |
|--|---------|-----------|--|
| | Cat.No. | Model No. | Description |
| | 92L07 | SV-MHPK1 | Mfg. Home Pipe Kit (SV) - 1/12 Pitch |
| | 92L08 | SV-MHPK2 | Mfg. Home Pipe Kit (SV) - 2/12 Pitch |
| | 92L09 | SV-FSTFE | Firestop Thimble (SV) - Flat, with Extension |
| | 92L10 | SV-FST1E | Firestop Thimble (SV) - 1/12 Pitch, with Extension |
| | 92L11 | SV-FST2E | Firestop Thimble (SV) - 2/12 Pitch, with Extension |
| | 92L06 | SVTE26 | Thimble Extension (SV) - 26 inches |

NOTE: DIAGRAMS & ILLUSTRATIONS NOT TO SCALE.

INSTALLATION ACCESSORIES

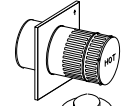
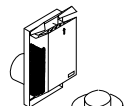
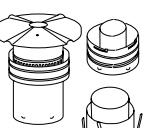
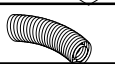
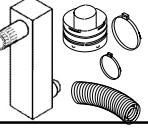
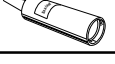
| Listed Secure Vent™ Components | | | |
|---|----------|--------------|--|
| | Cat. No. | Model No. | Description |
|  | 86L95 | SV4.5HTR | Horizontal Round Termination with Firestop/Spacer (96K80) and Adapter (74L61) |
|  | 86L97 | SV4.5HTS | Horizontal Square Termination with Firestop/Spacer (96K80) and Adapter (74L61) |
|  | 86L93 | SV4.5VTR | Vertical Termination with Adapter preinstalled |
|  | 77L70 | SV4.5L6 | 6 inch (152 mm) Vent Section |
| | 77L71 | SV4.5L12 | 12 inch (305 mm) Vent Section |
| | 77L72 | SV4.5L24 | 24 inch (610 mm) Vent Section |
| | 77L73 | SV4.5L36 | 36 inch (914 mm) Vent Section |
| | 77L74 | SV4.5L48 | 48 inch (1219 mm) Vent Section |
| | 77L75 | SV4.5LA | Telescopic Section |
|  | 77L76 | SV4.5E45 | 45 Degree Elbow |
|  | 77L77 | SV4.5E90 | 90 Degree Elbow |
| The following flashings come packaged with a storm collar. | | | |
|  | 77L78 | SV4.5F | Flat Roof Flashing |
| | 77L79 | SV4.5FA | 1/12 to 7/12 Adjust. Flashing |
| | 77L80 | SV4.5FB | 7/12 to 12/12 Adjust. Flashing |
|  | 77L81 | SV4.5SC6 | Storm Collars (6 collars/box) |
|  | 96K80 | SV4.5HF | Firestop/Spacer - Horizontal (3-1-1 spacing) |
| | 96K87 | SV4.5BF | Firestop/Spacer - Vertical (1-1-1 spacing) |
|  | 96K93 | SV4.5SU | Support Strap |
|  | 96K94 | SV4.5RSA | Attic Insulation Shield |
|  | 96K92 | SV4.5SP | Support Plate |
|  | 97K00 | SV4.5HGR | Heat Guard Round |
|  | 17M52 | SV4.5 HGS-1 | Heat Guard Square (1 - Pack) |
| | 17M53 | SV4.5 HGS-12 | Heat Guard Square (12 - Pack) |
|  | 96K98 | SV4.5HDR | Heat Deflector for Round Termination |

| Listed Secure Flex™ Components | | | |
|---|----------|-----------|--|
| | Cat. No. | Model No. | Description |
| These termination kits include firestop/spacer, gear clamps and flex adapter. | | | |
|  | 86L94 | SF-HTR | Horizontal Round Termination without Flex |
| | 77L82 | SFKIT12R | Flex Round Term. with 12 in. (305 mm) of *compressed Flex |
| | 77L83 | SFKIT18R | Flex Round Term. with 18 in. (457 mm) of *compressed Flex |
| | 77L84 | SFKIT24R | Flex Round Term. with 24 in. (610 mm) of *compressed Flex |
| | 77L85 | SFKIT36R | Flex Round Term. with 36 in. (914 mm) *compressed Flex |
| | 77L86 | SFKIT48R | Flex Round Term. with 48 in. (1219 mm) of *compressed Flex |
| These termination kits include firestop/spacer, gear clamps and flex adapter. | | | |
|  | 86L96 | SF-HTS | Horizontal Square Termination without Flex |
| | 77L87 | SFKIT12S | Flex Square Term. with 12 in. (305 mm of *compressed Flex |
| | 77L88 | SFKIT18S | Flex Square Term. with 18 in. (457 mm) of *compressed Flex |
| | 77L89 | SFKIT24S | Flex Square Term. with 24 in. (610 mm) of *compressed Flex |
| | 77L90 | SFKIT36S | Flex Square Term. with 36 in. (914 mm) of *compressed Flex |
| | 77L91 | SFKIT48S | Flex Square Term. with 48 in. (1219 mm) of *compressed Flex |
|  | 56L74 | SFVT30 | Vertical Termin. for Flex (flat to 6/12) with Flex Adapter, section of rigid vent, roof support collar assembly, roof flashing and storm collar. |
| | 56L75 | SFVT45 | Vertical Termin. for Flex (6/12 to 12/12) with Flex Adapter section of rigid vent, roof support collar assembly, roof flashing and storm collar. |
|  | 60L10 | SF-18 | 18 ft. (5.49 m) *compressed Flex |
| | 98K03 | SF-12 | 12 ft.(3.66 m) *compressed Flex |
|  | 87L01 | SFHRK | Snorkel Riser Kit with Flex Adapter, a section of Flex, and Gear Clamps |
|  | 10K81 | SFMP | Mil Pac Black Hi-Temperature Sealant |
|  | 91L66 | SF-GC4-6 | Gear Clamp 4.5in. (114 mm) for Flex (6 pieces) |
| | 91L67 | SF-GC7-6 | Gear Clamp 7.5 in. (190.5 mm) for Flex (6 pieces) |
|  | 19M40 | SF4.5HF | Firestop/Spacer - Horizontal (3-1-1 spacing) |
| | 19M41 | SF4.5BF | Firestop/Spacer - Vertical (1-1-1 spacing) |

* All compressed flex vents can be expanded up to two times.

GAS CONVERSION KITS

WARNING: THIS CONVERSION KIT SHALL BE INSTALLED BY A QUALIFIED SERVICE AGENCY IN ACCORDANCE WITH THE MANUFACTURER'S INSTRUCTIONS AND ALL APPLICABLE CODES AND REQUIREMENTS OF THE AUTHORIZED AGENCY HAVING JURISDICTION. IF THE INFORMATION IN THESE INSTRUCTIONS IS NOT FOLLOWED EXACTLY, A FIRE, EXPLOSION OR PRODUCTION OF CARBON MONOXIDE MAY RESULT CAUSING PROPERTY DAMAGE, PERSONAL INJURY OR LOSS OF LIFE. THE INSTALLATION IS NOT PROPER AND COMPLETE UNTIL THE OPERATION OF THE CONVERTED APPLIANCE IS CHECKED AS SPECIFIED IN THE OWNER INSTRUCTIONS SUPPLIED WITH THE KIT. THE QUALIFIED SERVICE AGENCY PERFORMING THIS INSTALLATION ASSUMES RESPONSIBILITY FOR THIS CONVERSION.

AVERTISSEMENT: CET ÉQUIPEMENT DE CONVERSION SERA INSTALLÉ PAR UNE AGENCE QUALIFIÉE DE SERVICE CONFORMÉMENT AUX INSTRUCTIONS DU FABRICANT ET TOUTES EXIGENCES ET CODES APPLICABLES DE L'AUTORISÉ AVOIR LA JURIDICTION. SI L'INFORMATION DANS CETTE INSTRUCTION N'EST PAS SUIVIE EXACTEMENT, UN FEU, EXPLOSION OU PRODUCTION DE PROTOXYDE DE CARBONE PEUT RÉSULTER LE DOMMAGES CAUSER DE PROPRIÉTÉ, PERTE OU BLESSURE PERSONNELLE DE VIE. L'AGENCE QUALIFIÉE DE SERVICE EST ESPONSABLE DE L'INSTALLATION PROPRE DE CET ÉQUIPEMENT. L'INSTALLATION N'EST PAS PROPRE ET COMPLÈTE JUSQU'À L'OPÉRATION DE L'APPAREIL CONVERTI EST CHÉQUE SUIVANT LES CRITÈRES ÉTABLIS DANS LES INSTRUCTIONS DE PROPRIÉTAIRE PROVISIONNÉES AVEC L'ÉQUIPEMENT.

In Canada:

THE CONVERSION SHALL BE CARRIED OUT IN ACCORDANCE WITH THE REQUIREMENTS OF THE PROVINCIAL AUTHORITIES HAVING JURISDICTION AND IN ACCORDANCE WITH THE REQUIREMENTS OF THE CAN1-B149.1 AND .2 INSTALLATION CODE.

LA CONVERSION DEVRA ÊTRE EFFECTUÉE CONFORMÉMENT AUX RECOMMANDATIONS DES AUTORITÉS PROVINCIALES AYANT JURIDICTION ET CONFORMÉMENT AUX EXIGENCES DU CODE D'INSTALLATION CAN1-B149.1 ET.2.

The natural to LP/propane gas conversion kit is supplied with the fireplace. The kit contains all the necessary components needed to complete the conversion process, including labeling that must be affixed to ensure safe operation.

The following steps detail the conversion procedure:

Step 1. Turn off the gas supply to the appliance.

- a. Open the control compartment access panel, by actuating the spring-loaded magnetic catches securing the panel, gently depressing the outer top corners of the panel until the catches "pop" the panel free and allowing it to swing out and down to open.
- b. Locate the two (2) latches at the top of the control compartment. To disengage the two latches from the bottom vee-flange of the glass enclosure panel, reach for the handles located towards the back of the latches and pull the handles down toward the front of the unit.
- c. Swing the bottom of the door out and raise it slightly to lift the top flange of the door frame away from the appliance.

Step 2. Carefully remove the log set. **Exercise care as not to break the log set.**

Step 3. Referring to *Figure 55* remove the front burner and then the rear burner.

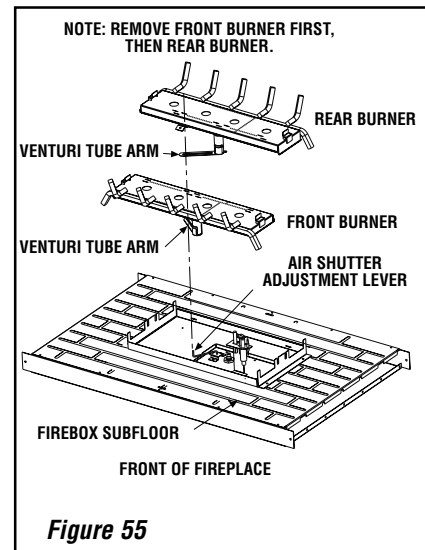

Millivolt Appliances

Step 4. Refer to *Figure 56 on page 27* and the instructions provided with the kit. Using a Torx T20, remove and discard the three pressure regulator mounting screws. Remove the pressure regulator, spring, poppet, diaphragm and bushing. **Discard all removed components.** Ensure the rubber gasket installed on the back of the replacement pressure regulator is properly positioned and install the new pressure regulator using the new screws supplied with the kit. Tighten screws to 25 in. lb. torque.

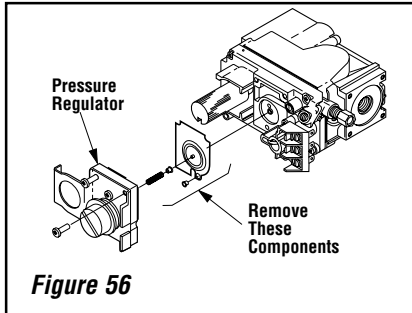

Step 5. Attach manometer to the manifold side pressure test fitting and verify manifold pressure reads 10.0 inches water column (2.49 kPa) for propane gas.

Step 6. Refer to **Figure 57** and remove the pilot hood assembly to access the hexed pilot orifice. Remove and replace the orifice with the one provided with the kit.

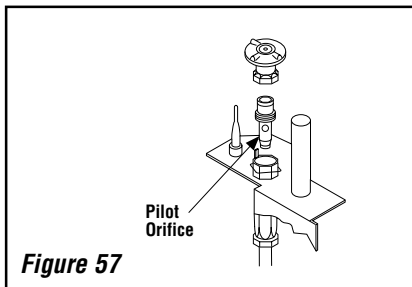

Step 7. (Refer to **Figure 55** on page 26)

- A. Remove the two orifices from the manifold and replace them with the ones provided in the kit. The following table shows the orifice sizes for the propane models. **Figure 58** illustrates the orifice.

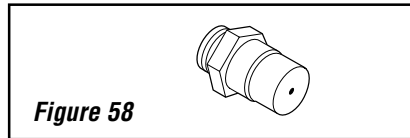

- B. Install rear burner first, followed by front burner, as shown in **Figure 59**. Ensure that the arm of the venturi of each burner is hooked onto the air shutter adjustment lever (refer to **Figure 55** on page 26). The primary air opening can be adjusted by rotating the adjustment lever from beneath the firebox floor. Rotate the adjustment lever fully counter clockwise for propane gas systems (**Refer to Figure 52** on page 23).

| Model No. | Orifice size* |
|-----------|---------------|
| | Prop. |
| DMSTNM-2 | #55 |
| DMPFNM-2 | #55 |

* Each model has two burners. Each burner contains one of these orifices.

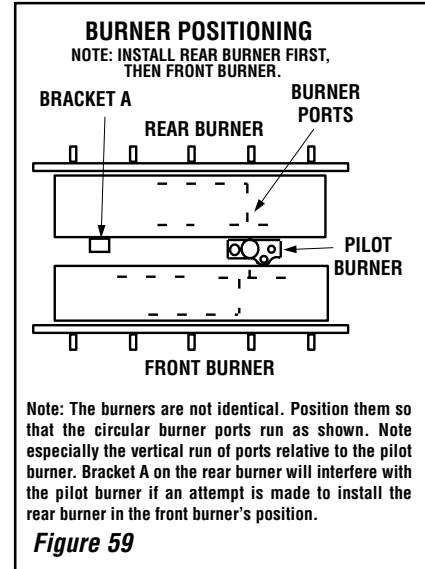

Step 8. Reassemble the remaining components by reversing the procedures outlined in the preceding steps. Use pipe joint compound or Teflon tape on all pipe fittings before installing (ensure propane resistant compounds are used in propane applications, do not use pipe joint compounds on flare fittings).

Step 9. Attach the conversion label provided in the conversion kit to the rating plate on the appliance.

Step 10. Turn on gas supply and test for gas leaks.

The manufacturer reserves the right to make changes at any time, without notice, in design, materials, specifications, prices and also to discontinue colors, styles and products. Consult your local distributor for fireplace code information.