

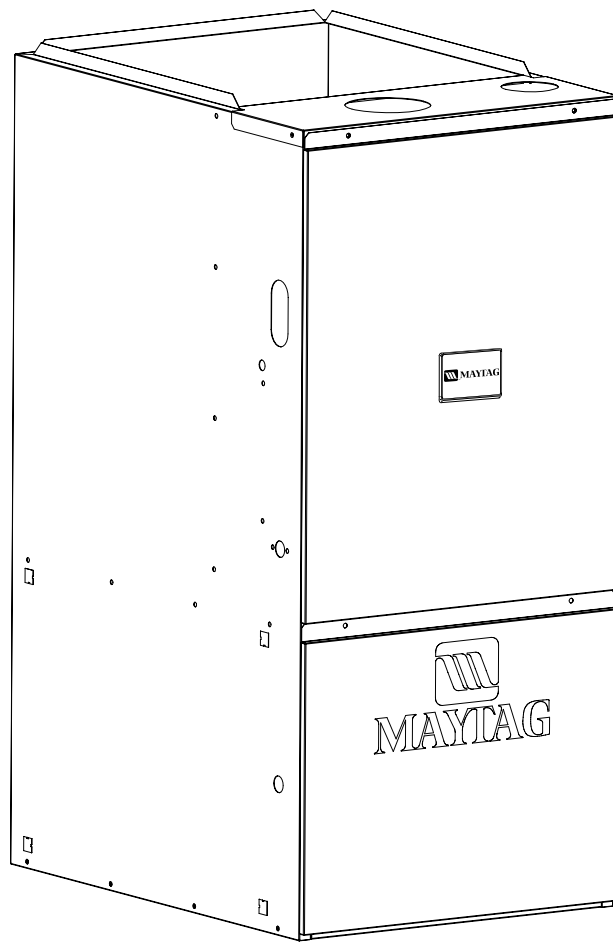

TECHNICAL SPECIFICATIONS

*Model MGF1TC 2 Stage Series Upflow/Horizontal
Model MGF1TL 2 Stage Series Downflow*



M1000 Product Line

**High Efficiency / 90+ AFUE Direct Vent or
Non Direct Vent Condensing Furnace**

- **10 YEAR WARRANTY**
- **WORRY-FREE PERFORMANCE**



The high efficiency 2-Stage gas furnace may be installed free standing in a utility room, basement, or enclosed in an alcove or closet. With kit, the upflow model converts easily to horizontal application. The extended flush jacket provides a pleasing “appliance appearance.” Design certified by the CSA International (Canadian Standards Association).

Features and Benefits

- **Best warranty in the business** —
 - A lifetime warranty on the heat exchanger to the original owner.
 - 10 Year Parts Warranty.
- **100% fired and tested** — All units and each component (both mechanical and electrical) are tested on the manufacturing line.
- **Best packaging in the industry** — Unique design assures product will arrive to the homeowner dent free.
- **Clean and quiet operation** — Due to the unique design of in-shot burners, location of inducer and use of insulation.
- **Fixed 30 second blower delay** at burner start-up assures a warm duct temperature at furnace start-up. Adjustable blower off settings (60, 120, 160 and 180 seconds).
- **Fixed 30-second post purge** increases life of heat exchanger.
- **SmartStart™ Control Board** — Provides extended life to ignitors in furnaces using hot surface ignition technology. Programmed to learn the heat-up characteristics of the ignitor, then adapt the ignition time to the characteristics of the furnace so the ignitor is energized appropriately.
- **Dependable, hot surface ignitor** — Innovative application of an appliance type ignitor with a 20-year history of reliability, assures no call-backs because of handling.
- **Color coded wire harness** — Designed to fit the components, all with quick-connect fittings for ease of service and replacement.
- **Tubular primary heat exchanger** — Heavy gauge aluminized steel heat exchanger assures a long life.
- **Stainless steel** secondary heat exchanger assures a long life.
- **Fixed cooling cycle blower-off delay (TDR)** increases cooling performance when matched with a Maytag coil.
- **Approved for direct vent furnace, category IV venting system** – May be vertically or horizontally vented using either a one-pipe or two-pipe system for maximum flexibility in installation.
- **Fully insulated blower cabinet** for quiet operation.
- **Variable speed blower** — Maximizes air conditioner and heat pump efficiencies. On selected units, SEER ratings up to 16 and HSPF ratings up to 8.5 are ARI listed.
- **LP convertible** — Simple burner orifice and regulator spring change for ease of convertibility.
- **Factory installed drain system** — for reliable performance.
- **Diagnostic light flashes identify limit failure, pressure switch failure and improper ground and polarization** — for easy troubleshooting.
- **Incorporates integrated control board** with connections for electronic air cleaner, humidifier and twinning.
- **Two piece door design** enhances furnace appearance and uses screw fasteners for great fit and accessibility.
- **3 amp fuse** protection against low voltage shorts; protects transformer and control board.
- **Low voltage terminal board** for easy field wiring.

High Efficiency Upflow 92+ Gas Furnace

Roll-out switch.

Aluminized steel in-shot burners, hot surface ignitor and redundant gas valve provide safe, reliable ignition and efficient combustion.

Remote flame sensor for proof of carry-over.

Supply air limit.

Two Stage Gas Valve.

Vent switch protects against blocked flue.

Counterflow heat exchanger orientation and aluminized steel tubular design, means improved efficiency and durability. (Not Shown)

SmartStart™ integrated control monitors the burner flame and limit circuit continuously. Blower timing has adjustable OFF settings. Provides humidifier and electronic air cleaner connections.

Front door screw fasteners ensure tight fit.

Vent Switch protects against blocked flue.

Induced draft blower provides quiet and reliable operation.

Fully Insulated blower compartment.

Variable speed motor/blower provides quiet airflow, reliable operation, and is installed on a slide out track.

Factory installed drain for reliable performance.

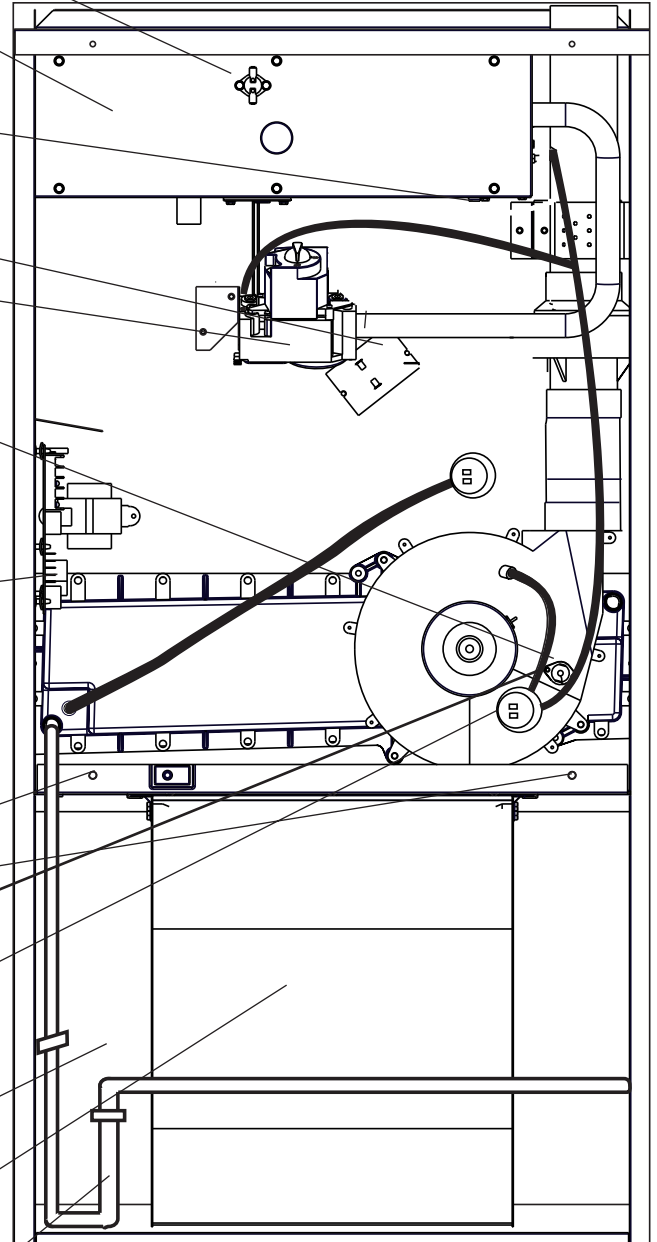

High Efficiency Downflow 90+ Gas Furnace

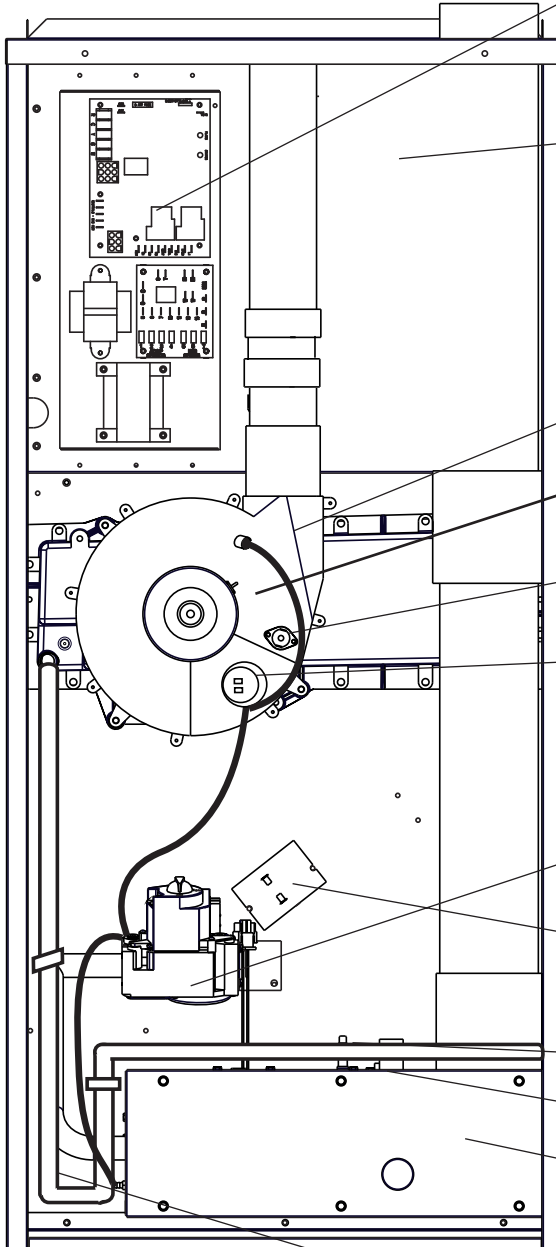

SmartStart™ integrated control monitors the burner flame and limit circuit continuously. Blower timing has adjustable OFF settings. Provides humidifier and electronic air cleaner connections.

Variable Speed motor/blower provides quiet airflow, reliable operation, and is installed on a slide-out track. (Not shown)

Fully Insulated blower compartment.

Induced draft blower provides quiet and reliable operation.

Vent switch protects against blocked flue.

Pressure switch assures proper operation of the induced draft system.

Two Stage Gas Valve.

Counterflow heat exchanger orientation and aluminized steel tubular design, means improved efficiency and durability. (Not shown)

Supply air limit.

Remote flame sensor for proof of flame carry-over.

Roll-out switch.

Aluminized steel in-shot burners, hot surface ignitor and redundant gas valve provide safe, reliable ignition and efficient combustion.

Factory installed drain for reliable performance.

DIMENSIONS

Upflow/Horizontal Furnace

Model Number MGF1TC	High Fire Furnace Btuh	Low Fire Furnace Input	Dimensions (inches)				Shipping Weight (lbs)
			A	B	C	D	
060	60,000	42,000	14 1/2	12 3/4	5 1/8	11 3/4	155
080	80,000	56,000	19 3/4	18 1/4	7 7/8	17 1/4	195
100	100,000	70,000	19 3/4	18 1/4	7 7/8	17 1/4	200
120	120,000	84,000	22 1/2	21	9 1/4	20	220

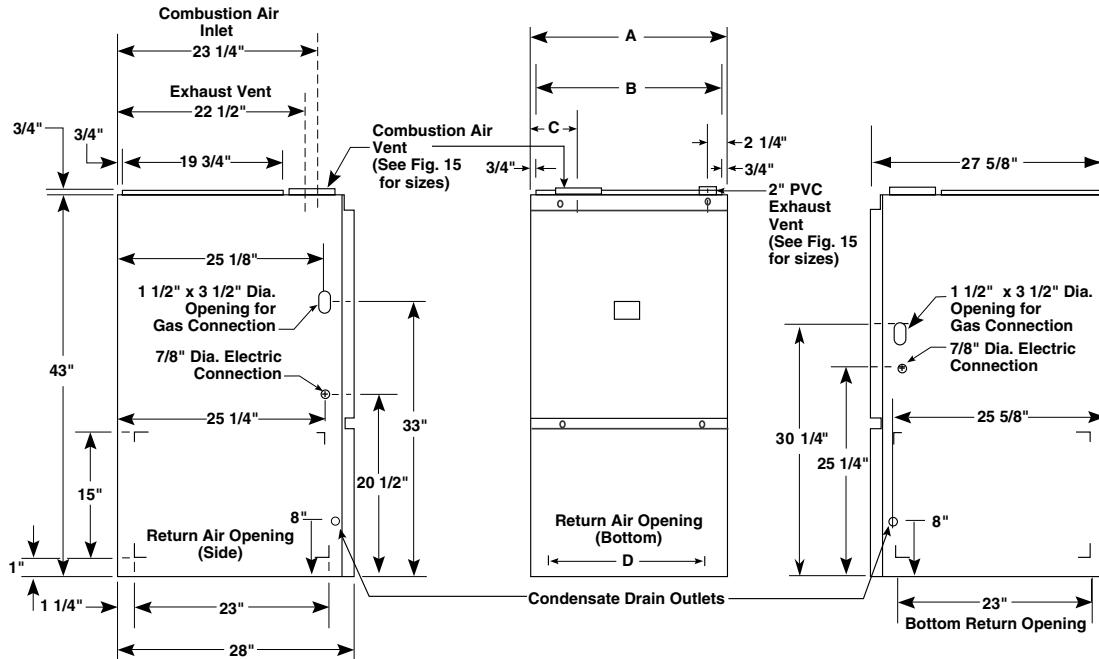

Downflow Furnace

Model Number MGF1TL	High Fire Furnace Btuh	Low Fire Furnace Input	Dimensions (inches)				Shipping Weight (lbs)
			A	B	C	D	
060	60,000	42,000	14 1/2	12 3/4	5 1/8	11 3/4	165
080	80,000	56,000	19 3/4	18 1/4	7 7/8	17 1/4	215
100	100,000	70,000	19 3/4	18 1/4	7 7/8	17 1/4	215
120	120,000	84,000	22 1/2	21	9 1/4	20	225

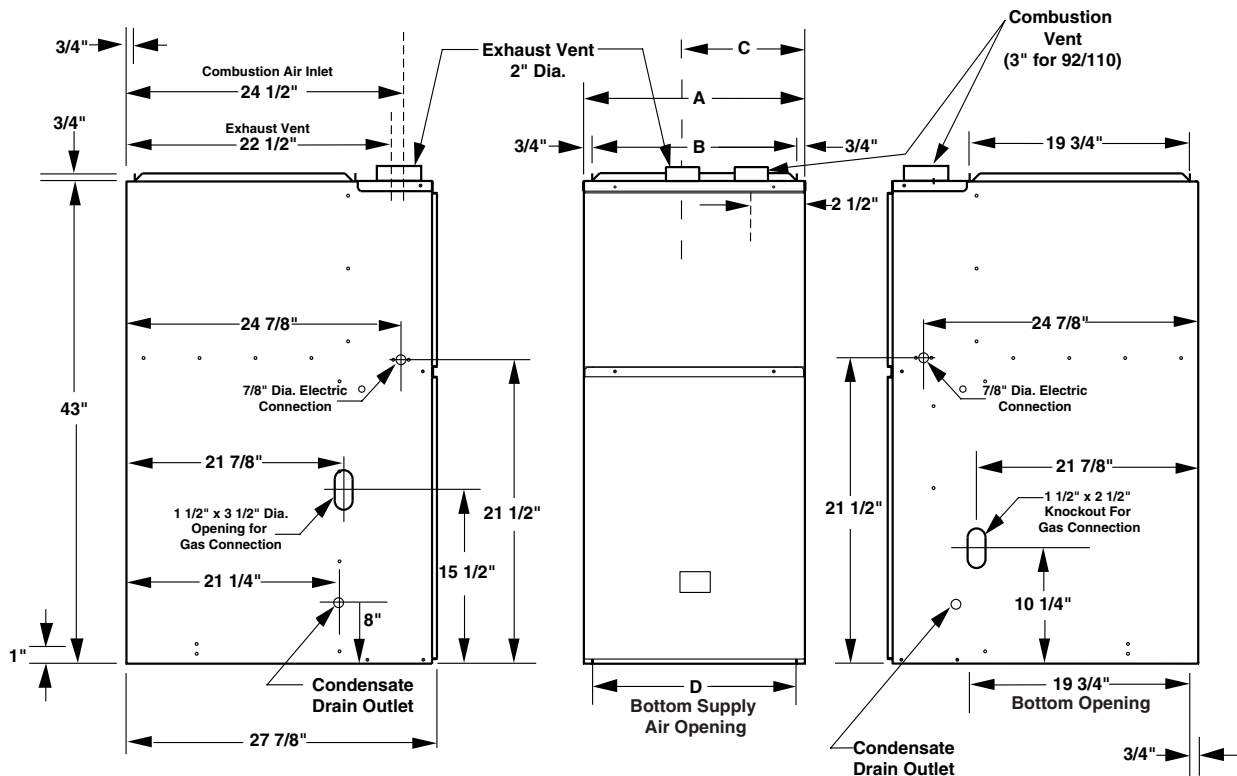

STANDARD EQUIPMENT

Direct vent; draft inducer; pressure switch; redundant main gas control; hot-surface ignition; 40VA transformer for air conditioner application; limit controls; direct drive motor; all models can be converted to use L.P. (propane) gas. Factory approved kits only must be used and are available as an optional accessory from your Maytag distributor.

SPECIFICATIONS

MODEL NUMBER *TC	060(C,N)-VA	080(C,N)-VB	100(C,N)-VB	120(C,N)-VC
High Fire Rated Input(Btu/h) (a)	60,000	80,000	100,000	120,000
High Fire Heating Capacity(Btu/h)	55,000	74,000	92,000	110,400
Low Fire Rated Input(Btu/h) (a)	42,000	56,000	70,000	84,000
Low Fire Heating Capacity(Btu/h)	38,000	50,400	63,000	76,000
AFUE	92+	92+	92+	92+
Maximum Heating Ext. St. Press.(in WC)	0.5	0.5	0.5	0.5
Blower Wheel D x W	10 x 6	11 x 10	11 x 10	11 x 10
Motor H.P. -Type	1/2 - Variable	3/4 - Variable	3/4 - Variable	3/4 - Variable
Motor FLA	7.7	9.6	9.6	9.6
High Fire Temperature Rise Range(F)	35-65	35-65	35-65	45-75
Low Fire Temperature Rise Range(F)	35-65	35-65	35-65	40-70

MODEL NUMBER *TL	060(C,N)-VA	080(C,N)-VB	100(C,N)-VB	120(C,N)-VC
High Fire Rated Input(Btu/h) (a)	60,000	80,000	100,000	120,000
High Fire Heating Capacity(Btu/h)	54,000	72,000	90,000	110,000
Low Fire Rated Input(Btu/h) (a)	42,000	56,000	70,000	84,000
Low Fire Heating Capacity(Btu/h)	38,000	50,000	63,000	76,000
AFUE	90+	90+	90+	90+
Maximum Heating Ext. St. Press.(in WC)	0.5	0.5	0.5	0.5
Blower Wheel D x W	10 x 6	11 x 10	11 x 10	11 x 10
Motor H.P. -Type	1/2 - Variable	3/4 - Variable	3/4 - Variable	3/4 - Variable
Motor FLA	7.7	9.6	9.6	9.6
High Fire Temperature Rise Range(F)	35-65	30-60	35-65	45-75
Low Fire Temperature Rise Range(F)	35 - 65	30-60	35-65	45-75

() Can be C or N

Note: All models are 115V, 60 Hz. Gas Connections are 1/2" N.P.T. AFUE = Annual Fuel Utilization Efficiency.

(a) Ratings to 2,000 feet. Over 2,000 feet, reduce 4% for each 1,000 ft. above sea level.

VENTING

All models are approved for vertical non direct (1 pipe) and direct (2 pipe) venting applications. See Vent Table below for specified sizes and allowable lengths.

APPLICATION PVC, CPVC or ABS SCH. 40 Pipe Size	SINGLE PIPE LENGTH (ft.) with 1 long radius elbow**		DIRECT VENT, DUAL PIPE LENGTH (ft.) with 1 long radius elbow on each pipe**					
	Outlet 2"	Outlet 3"	Inlet/Outlet 2" 2"		Inlet/Outlet 3" 2"		Inlet/Outlet 3" 3"	
Models *(C,L) 060	65	200	40	40	40	40	110	110
Models *(C,L) 080	45	200	35	35	40	40	110	110
Models *(C,L) 100	40	200	25	25	40	40	110	110
Models *(C,L) 120	40	200	20	20	40	40	110	110

* NOTE:

1. Subtract 2.5 ft. for each additional 2" elbow and 3.5 ft. for each additional 3" elbow.
2. Two 45 degree elbows are equivalent to one 90 degree elbow.
3. One short radius elbow is equivalent to two long radius elbows.
4. Do not include termination elbows in calculation of vent length.
5. This table is applicable for elevations from sea level to 2000 ft. For higher elevations decrease vent pipe lengths by 8% per 1000 ft. of altitude.
6. Only the listed pipe materials are approved for use with these Condensing Furnaces.

ACCESSORIES

Kit	Order Number	
U.S. LP Conversion Kit (0 to 10,000 ft.)	904404	
Canadian LP Gas Conversion Kit (0 to 4,500 ft.)	904405	
Fossil Fuel Kit	914762	
Side Return Filter Kit	541036	
Bottom Return Horizontal Installation	A Cabinet	903088
	B Cabinet	903089
	C Cabinet	903090
Internal Side Return Filter Wire	903152	
Horizontal Installation Kit	903568	
Downflow "A" Combustion Floor Base	902974	
Downflow "B" Combustion Floor Base	902677	
Downflow "C" Combustion Floor Base	904108	

ELECTRICAL DATA

Furnace Input (Btuh)	Cabinet Width (in.)	Nominal Electrical Supply	Maximum Operating Voltage	Minimum Operating Voltage	Maximum Furnace Amperes	Minimum Wire Gauge	Maximum Fuse or Circuit Breaker Amps*
60,000	14.50	115-60-1	127	103	12	14	15
80,000	19.75	115-60-1	127	103	12	14	15
100,000	19.75	115-60-1	127	103	12	14	15
120,000	22.50	115-60-1	127	103	12	14	15

* Time-delay fuses or HACR-type circuit breakers are required.

Thermostat Wire Gauge	Recommended Thermostat Wire Length	
	2-wire (heating)	4 or 5-wire (cooling)
24	55 ft.	25 ft.
22	90 ft.	45 ft.
20	140 ft.	70 ft.
18	225 ft.	110 ft.

VENT KITS

Kit Description	Order Number
2" Concentric Vent Kit	904177
3" Concentric Vent Kit	904176
Neutralizer Kit (all models)	902377
Side Wall Vent Kit	904347

IDENTIFICATION CODE

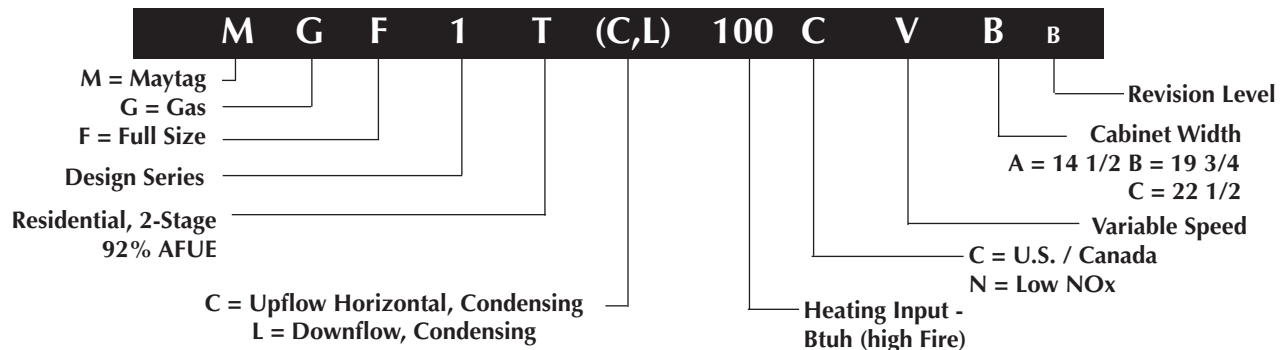

CAPACITIES — Furnace Airflow Data

Cooling/Heat Pump Airflow Settings

CFM	SWITCH NUMBER							Nominal A/C and HP Capacity		
	LOW	HIGH	1	2	3	4	5		6	7
300	400	0	0	0	1					
330	480	0	0	0	0					1 TON
390	550	0	0	1	0					1.5 TON
420	600	1	0	0	1					1 TON
500	720	1	0	0	0					1.5 TON
550	800	1	0	1	0					2 TON
580	830	0	1	0	1					2 TON
640	930	0	1	0	0					2.5 TON
700	1010	1	1	0	1					3 TON
730	1070	0	1	1	0					2.5 TON
780	1140	1	1	0	0					3 TON
850	1230	1	1	1	0					3 TON

NOTE: 0 = OFF 1 = ON

***TC/L 060 (1/2 HP)**
Cooling/Heat Pump Airflow Settings

CFM	SWITCH NUMBER							Nominal A/C and HP Capacity		
	LOW	HIGH	1	2	3	4	5		6	7
500	720	0	0	0	1					
550	800	0	0	0	0					2 TON
610	880	0	0	1	0					2.5 TON
650	945	1	0	0	1					3 TON
720	1050	1	0	0	0					3 TON
800	1155	1	0	1	0					3.5 TON
900	1305	0	1	0	1					4 TON
1000	1450	0	1	0	0					4 TON
1060	1530	1	1	0	1					5 TON
1100	1595	0	1	1	0					4 TON
1170	1700	1	1	0	0					5 TON
1290	1870	1	1	1	0					5 TON

NOTE: 0 = OFF 1 = ON

***TC/L 080/100/120 (3/4 HP)**
Cooling/Heat Pump Airflow Settings

Heating Airflow Settings

Nominal Airflow (CFM) and Temperature Rises (degree F)																		
			*T(C,L)-060(CN)-VA Models				*T(C,L)-080(CN)-VB Models				*T(C,L)-100 (CN)-VB Models				*T(C,L)-120(CN)-VA Models			
Switches			Low Fire Input		High Fire Input		Low Fire Input		High Fire Input		Low Fire Input		High Fire Input		Low Fire Input		High Fire Input	
5	6	7	43,000	60,000	56,000	80,000	70,000	100,000	84,000	120,000								
0	0	#	600	60	700	75	660	72	1090	63	660	90	1090	80	660	108	1090	96
1	0	#	660	54	800	65	750	64	1240	57	750	80	1240	70	750	95	1240	84
0	1	#	800	45	1048	50	1220	40	1680	42	1220	49	1680	52	1220	59	1680	62
1	1	#	900	40	1296	40	1300	37	1880	37	1300	46	1880	46	1300	55	1880	56

Switch not used - Can be 0 or 1.

Notes:

1. Recommended temperature rises are highlighted in bold.
2. Airflow rates of 1800 CFM or more require two return air connections. Data is for operation with filter(s).
3. Temperature rises in the table are approximate. Actual temperature rises may vary.
4. Temperature rises that are shaded grey are for reference only. These conditions are not recommended.
5. For single stage cooling, the indoor blower will operate at the CFM listed in the high column.



Before purchasing this appliance, read important energy cost and efficiency information available from your retailer. Specifications and illustrations subject to change without notice and without incurring obligations.

Maytag is a registered trademark of the Maytag Corporation and is used under license to NORDYNE Inc.

038C-1006 (Replaces 038C-0906)

Printed in U.S.A. (10/06)