

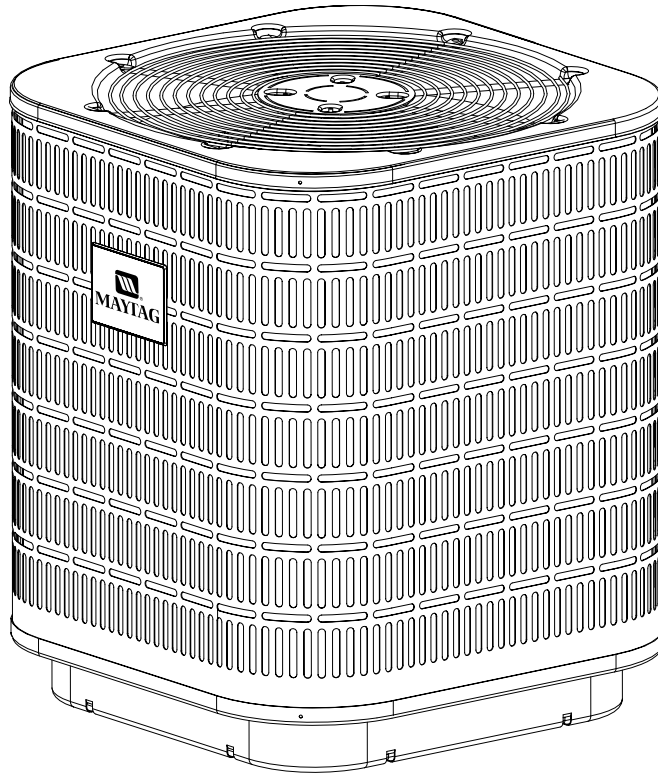

TECHNICAL SPECIFICATIONS

Model DT5BD Series



M1000 Product Line

**High Efficiency Heat Pumps
13+ SEER — 1.5 - 5 Ton Capacity**

- **10 YEAR
WARRANTY**
- **WORRY-FREE
PERFORMANCE**



The DT5BD Series of heat pumps offers exceptional performance. The heat pump, when combined with our engineered coils or air handlers, offers a line of quality, split system heating and cooling equipment. The DT5BD is rated at 13 SEER and 8.0 HSPF when matched with our air handlers. When matched with our variable speed air handler, or our variable speed blower kits, the DT5BD is rated up to 14 SEER and 8.5 HSPF.

FEATURES and BENEFITS

- **Durable, Attractive Cabinet** – Designed using galvanized steel with a polyester urethane finish. The 950 hour salt spray finish is 1.5 mil thick and resists corrosion 50% better than comparable units.
- **Copper Tube / Aluminum Fin Coils** – Both indoor and outdoor coils are designed to optimize heat transfer, minimize size and cost, and increase durability and reliability.
- **Permanently Lubricated Motor** – A heavy duty PSC motor for long lasting reliability and quiet operation. Requires no maintenance and is completely protected from rain and snow.
- **Full Service Valves** – These brass valves are easily accessible and simplify servicing of the refrigeration system.
- **Steel Guard™** – Protects the unit coil from being damaged by balls, lawnmowers, hail, etc.
- **Time / Temperature Defrost** – A reliable, industry standard control offers various time settings to meet any type climate.
- **Removable Top Grille Assembly** – Allows ease of service from the top without disconnecting fan motor leads.
- **One Piece Top/Orifice** – Designed for maximum airflow and quiet operation.
- **Common Suction Service Port** – This port allows the contractor to read the suction pressure in all modes of operation without removing any panels, saving time and increasing serviceability.
- **2-1/2" Pedestal Base** – The sturdy base keeps the bottom of the coil out of harms way. Secondly, the base has weep holes along the edge to allow the water from the defrosting coil and rain to flow away from the unit.
- **Five Minute Restart Time Delay** – When the unit shuts down, a five minute delay keeps the unit from restarting, eliminating the highest cause for compressor failure.
- **Suction Accumulator** – Protection from liquid flood back and future compressor failures.
- **Hot Gas Muffler** – Reduces compressor noise and vibration.
- **Easy Compressor and Control Access** – Designed to make servicing easier for the contractor, access panels are provided to all controls and the compressor from the side of the unit.
- **10 Year Limited Parts Warranty** – The best in the industry and has proven to be a major benefit to the consumer.

DIMENSIONS/OUTDOOR SECTION

DT5BD-	018K	024K	030K	036K	042K	048K	060K
H	26-1/2	26-1/2	38-1/2	42-1/2	38-1/2	42-1/2	42-1/2
W	30-1/2	30-1/2	30-1/2	30-1/2	30-1/2	30-1/2	30-1/2
D	30-1/2	30-1/2	30-1/2	30-1/2	30-1/2	30-1/2	30-1/2

Air Discharge
Allow Adequate Clearance for Airflow

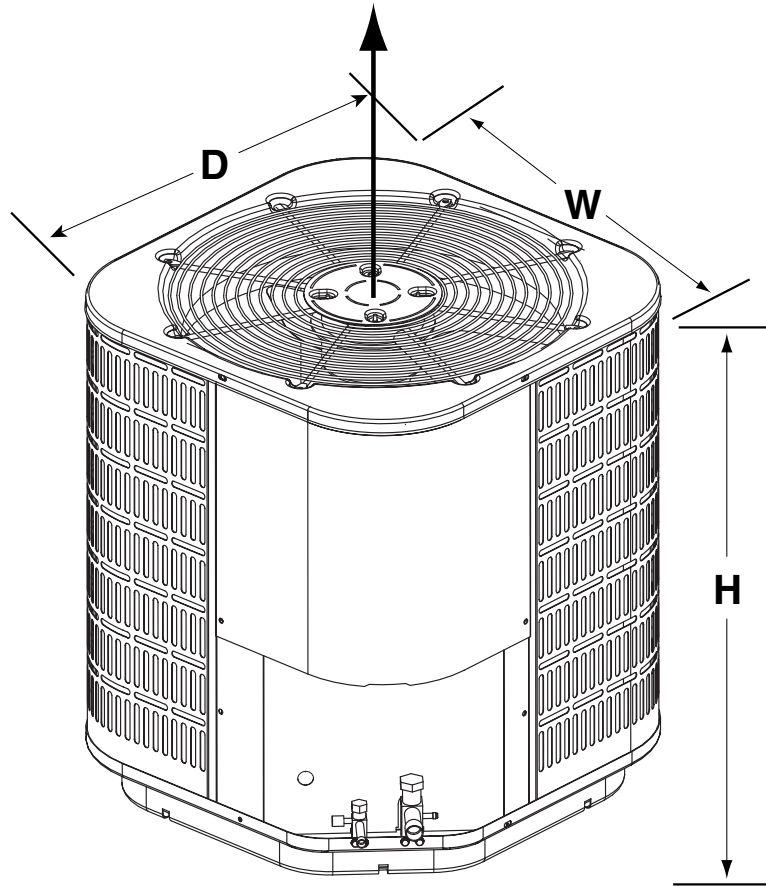

IDENTIFICATION CODE

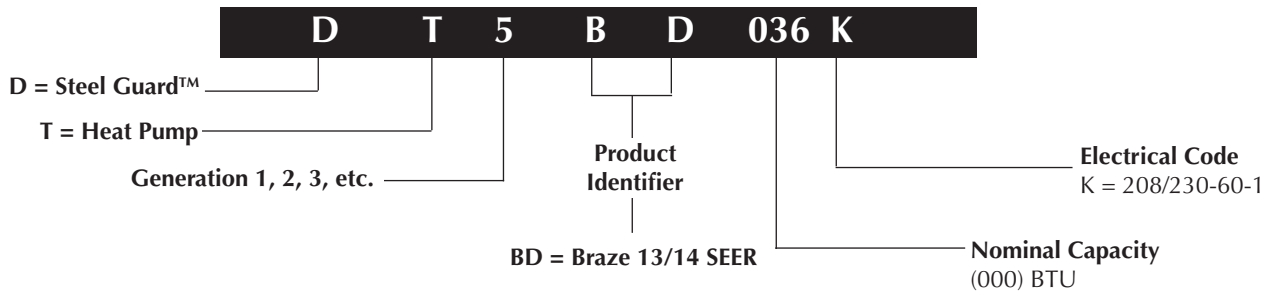

PHYSICAL AND ELECTRICAL SPECIFICATIONS / OUTDOOR UNITS

13+ SEER — High Efficiency — Single Phase

Model Number DT5BD-		018K	024K	030K	036K	042K	048K	060K	
Electrical Data	Volts-Cycles-Phase (1)	208/230-60-1	208/230-60-1	208/230-60-1	208/230-60-1	208/230-60-1	208/230-60-1	208/230-60-1	
	Total Amps	10.3	12.2	13.0	17.4	19.4	21.8	29.4	
	Delay Fuse Max. (2)	20	25	30	35	40	45	60	
	Min. Circuit Ampacity	13.4	15.0	16.0	21.5	23.4	26.9	36.4	
Component Data	Coil	Area	15.17	15.17	22.88	25.42	22.88	25.42	25.42
		Rows-FPI	1 - 18	1 - 18	1 - 20	1 - 20	2 - 16	2 - 16	2 - 16
		Tube Dia	3/8" O.D.	3/8" O.D.	3/8" O.D.	3/8" O.D.	3/8" O.D.	3/8" O.D.	3/8" O.D.
	Fan Motor	Type	PSC	PSC	PSC	PSC	PSC	PSC	PSC
		Amps	0.91	0.91	1.00	1.00	1.00	1.4	1.4
		HP	1/8	1/8	1/4	1/4	1/4	1/4	1/4
	Fan Blade	Dia-# Blades	24" - 3	24" - 3	24" - 3	24" - 3	24" - 3	24" - 3	24" - 3
		SCFM	2370	2370	3000	3000	3000	4000	4000
	Compressor Data	RLA	10	11.3	12	16.4	18.4	20.4	28
		LRA	41	51	60	83	95	109	148
Refrigerant suction line- Length/O.D. (Liq. Line All Lengths - 3/8" O.D.)	0-24 ft.	3/4"	3/4"	3/4"	3/4"	7/8"	7/8"	7/8"	
	25-39 ft.	3/4"	3/4"	3/4"	7/8" (3)	7/8"	7/8"	1-1/8" (4)	
	40-75 ft.	3/4"	3/4"	7/8" (3)	7/8" (3)	7/8"	1-1/8" (4)	1-1/8" (4)	
Refrigerant charge in ounces (Outdoor unit, Indoor Unit 15' Line Set)		93	126	144	155	248	248	268	
Weight Approximate (lbs.)	Net	166	171	190	204	252	276	285	
	Ship	175	180	200	215	265	290	300	

(1) Operating Voltage Range: 187v min. — 253v max.

(2) HACR Type Circuit Breakers may be used.

(3) Requires 7/8" to 3/4" reducer from line to unit.

(4) Requires 1 1/8" to 7/8" reducer from line to unit.

ACCESSORIES - CONDENSING UNIT

Start Assist Kit - 912933

Provides additional starting torque for the compressor motor when operating with low line voltage or high operating temperatures.

Fan Delay Kit (TDR)

911758 - 80-second fan delay

COPPER WIRE SIZE — AWG (1% Voltage Drop)				
Supply Wire Length-Feet				Supply Circuit Ampacity
200	150	100	50	
6	8	10	14	15
4	6	8	12	20
4	6	8	10	25
4	4	6	10	30
3	4	6	8	35
3	4	6	8	40
2	3	4	6	45
2	3	4	6	50

Wire Size based on N.E.C. for 60° type copper conductors.

SYSTEM HEATING & COOLING CAPACITIES

13+ SEER — High Efficiency — Single Phase

Outdoor Unit	Indoor Piston Coil	Cooling Capacity BTUH	SEER	EER	Heating Capacity BTUH @47 F	HSPF	SCFM	Indoor Orifice
018K	C5B(A,H)-024(U,C)-A+TDR+LLS	18,000	13.0	12.4	17,800	8.0	600	0.051
018K	C5B(A,H)-025(U,C)-A+TDR+LLS	18,000	13.0	12.4	17,800	8.0	600	0.051 (1)
024K	C5B(A,H)-025(U,C)-A+TDR+LLS	24,000	13.0	12.4	22,400	7.7	750	0.061
024K	C5B(A,H)-025(U,C)-B+TDR+LLS	24,000	13.0	12.4	22,400	7.7	750	0.061
030K	C5B(A,H)-030(U,C)-A+TDR+LLS	29,000	13.0	12.1	28,600	7.7	870	0.068
030K	C5B(A,H)-030(U,C)-B+TDR+LLS	29,000	13.0	12.1	28,600	7.7	870	0.068
036K	C5B(A,H)-036(U,C)-B+TDR+LLS	35,400	13.0	11.7	36,000	8.0	1,140	0.078
042K	C5B(A,H)-042(U,C)-B+TDR+LLS	40,000	13.0	11.8	40,000	8.0	1,350	0.083
048K	C5B(A,H)-049(U,C)-C+TDR+LLS	45,500	13.0	11.3	47,500	8.0	1,500	0.090
060K	C5B(A,H)-060(U,C)-C+TDR+LLS+VSB-C	57,000	13.0	11.6	60,000	8.0	1,800	0.101

Outdoor Unit	Indoor Piston Air Handler B5BM-	Cooling Capacity BTUH	SEER	EER	Heating Capacity BTUH @47 F	HSPF	SCFM	Indoor Orifice
018K	024K-A+LLS	18,000	13.0	12.4	17,800	8.0	600	0.051
018K	025K-A+LLS	18,000	13.0	12.4	17,800	8.0	600	0.051 (1)
024K	025K-A+LLS	24,000	13.0	12.4	22,400	7.7	750	0.061
024K	025K-B+LLS	24,000	13.0	12.4	22,400	7.7	750	0.061
030K	030K-A+LLS	29,000	13.0	12.1	28,600	7.7	870	0.068
030K	030K-B+LLS	29,000	13.0	12.1	28,600	7.7	870	0.068
036K	036K-B+LLS	35,400	13.0	11.7	36,000	8.0	1,140	0.078
042K	042K-B+LLS	40,000	13.0	11.8	40,000	8.0	1,350	0.083
048K	049K-C+LLS	45,500	13.0	11.3	47,500	8.0	1,500	0.090
060K	060K-C+LLS	57,000	13.0	11.6	60,000	8.0	1,800	0.101

Outdoor Unit	Indoor TXV Coil	Cooling Capacity BTUH	SEER	EER	Heating Capacity BTUH @47 F	HSPF	SCFM
018K	C5B(A,H)-T24(U,C)-A+TDR	18,000	13.0	12.4	17,800	8.0	600
018K	C5B(A,H)-T25(U,C)-A+TDR	18,000	13.0	12.4	17,800	8.0	600
024K	C5B(A,H)-T25(U,C)-A+TDR	24,000	13.0	12.4	22,400	7.7	750
024K	C5B(A,H)-T25(U,C)-B+TDR	24,000	13.0	12.4	22,400	7.7	750
030K	C5B(A,H)-T30(U,C)-A+TDR	29,000	13.0	12.1	28,600	7.7	870
030K	C5B(A,H)-T30(U,C)-B+TDR	29,000	13.0	12.1	28,600	7.7	870
036K	C5B(A,H)-T36(U,C)-B+TDR	35,400	13.0	11.7	36,000	8.0	1,140
042K	C5B(A,H)-T42(U,C)-B+TDR	40,000	13.0	11.8	40,000	8.0	1,350
048K	C5B(A,H)-T49(U,C)-C+TDR	45,500	13.0	11.3	47,500	8.0	1,500
060K	C5B(A,H)-T60(U,C)-C+TDR+VSB-C	57,000	13.0	11.6	60,000	8.0	1,800

Outdoor Unit	Indoor TXV Air Handler B5BM-	Cooling Capacity BTUH	SEER	EER	Heating Capacity BTUH @47 F	HSPF	SCFM
018K	T24K-A	18,000	13.0	12.4	17,800	8.0	600
018K	T25K-A	18,000	13.0	12.4	17,800	8.0	600
024K	T25K-A	24,000	13.0	12.4	22,400	7.7	750
024K	T25K-B	24,000	13.0	12.4	22,400	7.7	750
030K	T30K-A	29,000	13.0	12.1	28,600	7.7	870
030K	T30K-B	29,000	13.0	12.1	28,600	7.7	870
036K	T36K-B	35,400	13.0	11.7	36,000	8.0	1,140
042K	T42K-B	40,000	13.0	11.8	40,000	8.0	1,350
048K	T49K-C	45,500	13.0	11.3	47,500	8.0	1,500
060K	T60K-C	57,000	13.0	11.6	60,000	8.0	1,800

(1) Field Supplied Piston

TDR = Time Delay Relay, included with Maytag furnace and air handler.

See Current ARI Directory for certified combinations and ratings.

SYSTEM HEATING & COOLING CAPACITIES (continued)

14 SEER — High Efficiency — Single Phase

Outdoor Unit	Indoor Piston Coil	Cooling Capacity BTUH	SEER	EER	Heating Capacity BTUH @47 F	HSPF	SCFM	Indoor Orifice
018K	C5B(A,H)-024(U,C)-B+TDR+LLS+VSB-B	18,100	14.0	12.2	16300	8.5	720	0.051
024K	C5B(A,H)-025(U,C)-B+TDR+LLS+VSB-B	24,800	14.0	12.4	22000	8.5	720	0.061
030K	C5B(A,H)-030(U,C)-B+TDR+LLS+VSB-B	29,400	14.0	12.5	28200	8.5	860	0.069
036K	C5B(A,H)-036(U,C)-B+TDR+LLS+VSB-B	35,800	14.0	12.4	35800	8.5	1,125	0.078
042K	C5B(A,H)-042(U,C)-B+TDR+LLS+VSB-B	40,500	14.0	12.3	41500	8.5	1,375	0.083
048K	C5B(A,H)-049(U,C)-C+TDR+LLS+VSB-C	46,000	14.0	12.4	46500	8.5	1,555	0.090

Outdoor Unit	Indoor Piston Air Handler B5VM-	Cooling Capacity BTUH	SEER	EER	Heating Capacity BTUH @47 F	HSPF	SCFM	Indoor Orifice
018K	024K-B+LLS	18,100	14.0	12.2	16300	8.5	720	0.051
024K	025K-B+LLS	24,800	14.0	12.4	22000	8.5	720	0.061
030K	030K-B+LLS	29,400	14.0	12.5	28200	8.5	860	0.069
036K	036K-B+LLS	35,800	14.0	12.4	35800	8.5	1,125	0.078
042K	042K-B+LLS	40,500	14.0	12.3	41500	8.5	1,375	0.083
048K	049K-C+LLS	46,000	14.0	12.4	46500	8.5	1,555	0.090

Outdoor Unit	Indoor Piston Air Handler B5BM-	Cooling Capacity BTUH	SEER	EER	Heating Capacity BTUH @47 F	HSPF	SCFM	Indoor Orifice
018K	024K-B+LLS+VSB-B	18,100	14.0	12.2	16300	8.5	720	0.051
024K	025K-B+LLS+VSB-B	24,800	14.0	12.4	22000	8.5	720	0.061
030K	030K-B+LLS+VSB-B	29,400	14.0	12.5	28200	8.5	860	0.069
036K	036K-B+LLS+VSB-B	35,800	14.0	12.4	35800	8.5	1,125	0.078
042K	042K-B+LLS+VSB-B	40,500	14.0	12.3	41500	8.5	1,375	0.083
048K	049K-C+LLS+VSB-C	46,000	14.0	12.4	46500	8.5	1,555	0.090

Outdoor Unit	Indoor TXV Coil	Cooling Capacity BTUH	SEER	EER	Heating Capacity BTUH @47 F	HSPF	SCFM
018K	C5B(A,H)-T24(U,C)-B+TDR+VSB-B	18,100	14.0	12.2	16300	8.5	720
024K	C5B(A,H)-T25(U,C)-B+TDR+VSB-B	24,800	14.0	12.4	22000	8.5	720
030K	C5B(A,H)-T30(U,C)-B+TDR+VSB-B	29,400	14.0	12.5	28200	8.5	860
036K	C5B(A,H)-T36(U,C)-B+TDR+VSB-B	35,800	14.0	12.4	35800	8.5	1,125
042K	C5B(A,H)-T42(U,C)-B+TDR+VSB-B	40,500	14.0	12.3	41500	8.5	1,375
048K	C5B(A,H)-T49(U,C)-C+TDR+VSB-C	46,000	14.0	12.4	46500	8.5	1,555

Outdoor Unit	Indoor TXV Air Handler B5VM-	Cooling Capacity BTUH	SEER	EER	Heating Capacity BTUH @47 F	HSPF	SCFM
018K	T24K-B	18,100	14.0	12.2	16300	8.5	720
024K	T25K-B	24,800	14.0	12.4	22000	8.5	720
030K	T30K-B	29,400	14.0	12.5	28200	8.5	860
036K	T36K-B	35,800	14.0	12.4	35800	8.5	1,125
042K	T42K-B	40,500	14.0	12.3	41500	8.5	1,375
048K	T49K-C	46,000	14.0	12.4	46500	8.5	1,555

Outdoor Unit	Indoor TXV Air Handler B5BM-	Cooling Capacity BTUH	SEER	EER	Heating Capacity BTUH @47 F	HSPF	SCFM
018K	T24K-B+VSB-B	18,100	14.0	12.2	16300	8.5	720
024K	T25K-B+VSB-B	24,800	14.0	12.4	22000	8.5	720
030K	T30K-B+VSB-B	29,400	14.0	12.5	28200	8.5	860
036K	T36K-B+VSB-B	35,800	14.0	12.4	35800	8.5	1,125
042K	T42K-B+VSB-B	40,500	14.0	12.3	41500	8.5	1,375
048K	T49K-C+VSB-C	46,000	14.0	12.4	46500	8.5	1,555

TDR = Time Delay Relay, included with Maytag furnace and air handler.

See current ARI Directory for certified combinations and ratings.



CERTIFICATION APPLIES ONLY
WHEN THE COMPLETE
SYSTEM IS LISTED
WITH ARI



We Encourage
Professionalism



Through Technician
Certification by NATE



Before purchasing this appliance, read important energy cost and efficiency information available from your retailer. Specifications and illustrations subject to change without notice and without incurring obligations.
Maytag is a registered trademark of the Maytag Corporation and is used under license.

104C-0706 (Replaces 104C-0606)

Printed in U.S.A. (07/06)