

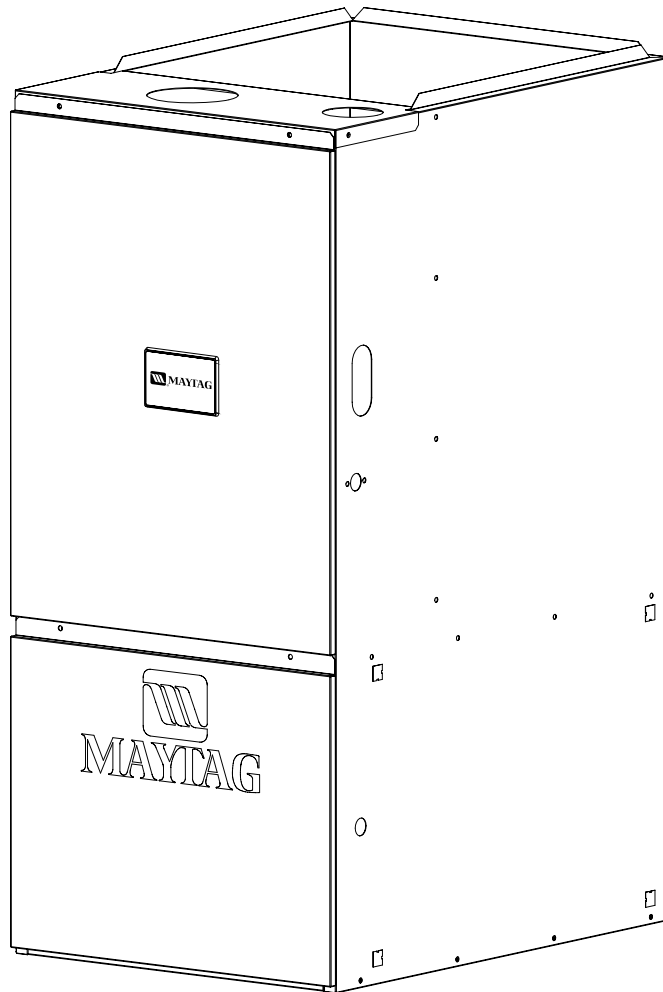

TECHNICAL SPECIFICATIONS

Model PGF1RC Series



M1010 Product Line

**High Efficiency 92+ AFUE Direct Vent or Non Direct Vent
Condensing Upflow/Horizontal Gas Furnace**

- **10 YEAR
WARRANTY**
- **WORRY-FREE
PERFORMANCE**
- **5 YEAR
DEPENDABILITY
PROMISE**



The high efficiency upflow gas furnace may be installed free standing in a utility room, basement, or enclosed in an alcove or closet. With kit, it converts easily to horizontal application. The extended flush jacket provides a pleasing “appliance appearance.” Design certified by the Canadian Standards Association (CSA). The product is truly designed with the contractor and the consumer in mind.

Features and Benefits

- **Best warranty in the business** —
 - A lifetime warranty on the heat exchanger.
 - 10 Year Limited Parts and Labor, 5 Year Dependability Promise.
- **100% fired and tested** — All units and each component (both mechanical and electrical) are tested on the manufacturing line.
- **Best packaging in the industry** — Unique design assures product will arrive to the homeowner dent free.
- **Clean and quiet operation** — Due to the unique design of in-shot burners, location of inducer and use of insulation.
- **Smart Start® state-of-the-art control board** learns the start-up characteristics of the furnace as installed in your home. It adapts to the most efficient start-up time extending the life of the igniter.
- **Fixed 30 second blower delay** at burner start-up assures a warm duct temperature at furnace start-up. Adjustable blower off settings (60, 120, 160 and 180 seconds).
- **Fixed 30-second post purge** increases life of heat exchanger.
- Dependable, hot surface ignitor — Innovative application of an appliance type ignitor with a 20-year history of reliability, assures no call-backs because of handling.
- **Color coded wire harness** — Designed to fit the components, all with quick-connect fittings for ease of service and replacement.
- **Tubular primary heat exchanger** — Heavy gauge aluminized steel heat exchanger assures a long life.
- **Stainless steel** secondary heat exchanger assures a long life.
- **Fixed cooling cycle blower-off delay (TDR)** increases cooling performance when matched with a Maytag coil.
- **Approved for direct vent furnace, category IV venting system** – May be vertically or horizontally vented using either a one-pipe or two-pipe system for maximum flexibility in installation.
- **Fully insulated blower cabinet** for quiet operation.
- **Variable speed blower kit** is available to maximize air conditioner and heat pump efficiencies. On selected units, SEER ratings up to 14 and HSPF ratings up to 8.5 are ARI listed.
- **Multi-speed direct drive blower** — Designed to give a wide range of cooling capacities. 40VA transformer included.
- **LP convertible** — Simple burner orifice and regulator spring change for ease of convertibility.
- **Factory installed drain system** for reliable performance.
- **Diagnostic light flashes identify limit failure, pressure switch failure and improper ground and polarization** — for easy troubleshooting.
- **Incorporates integrated control board** with connections for electronic air cleaner, humidifier and twinning.
- **Two piece door design** enhances furnace appearance and uses screw fasteners for great fit and accessibility.
- **3 amp fuse** protection against low voltage shorts; protects transformer and control board.
- **Low voltage terminal board** for easy field wiring.
- **Components and Controls** — Designing quality into our products means selecting manufacturers that have a reputation for delivering high quality, dependable products.

Roll-out Switch.

Remote Flame Sensor
for proof of carry-over.
(Not Shown)

**Aluminized Steel In-shot
Burners, Hot Surface Ignitor
and Redundant Gas Valve**
provide safe, reliable ignition
and efficient combustion.

Supply Air Limit.

Pressure Switch assures
proper operation of the
induced draft system.

Counterflow Heat Exchanger
orientation and aluminized
steel tubular design, means
improved efficiency and
durability.

**SmartStart™ Integrated
Control** monitors the burner
flame and limit circuit
continuously. Blower
timing has adjustable OFF
settings. Provides humidifier
and electronic air cleaner
connections.

Induced Draft Blower provides
quiet and reliable operation.

Vent Switch protects against
blocked flue.

Front Door Screw Fasteners
ensure tight fit.

Fully Insulated blower
compartment.

**Multi-speed PSC Motor/
Blower** provides quiet
airflow, reliable operation
and is installed on a slide
out track.

Factory Installed Drain
for reliable performance.

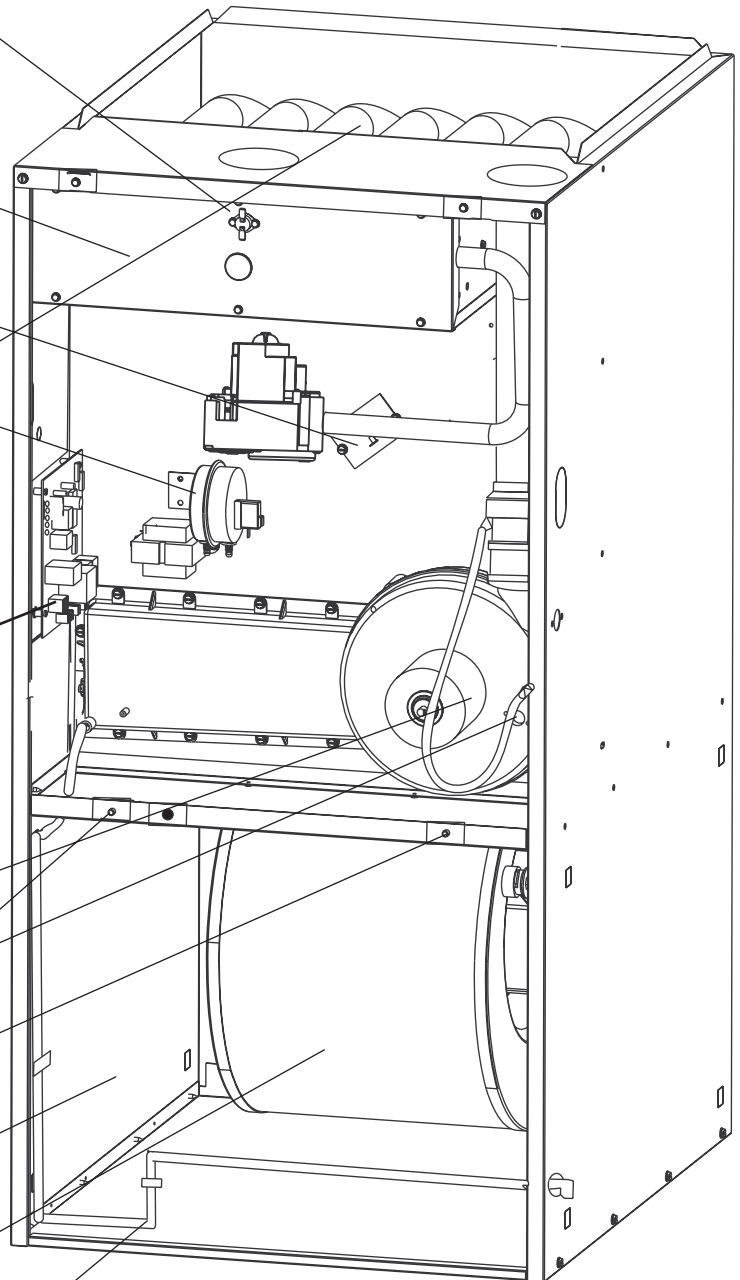

DIMENSIONS

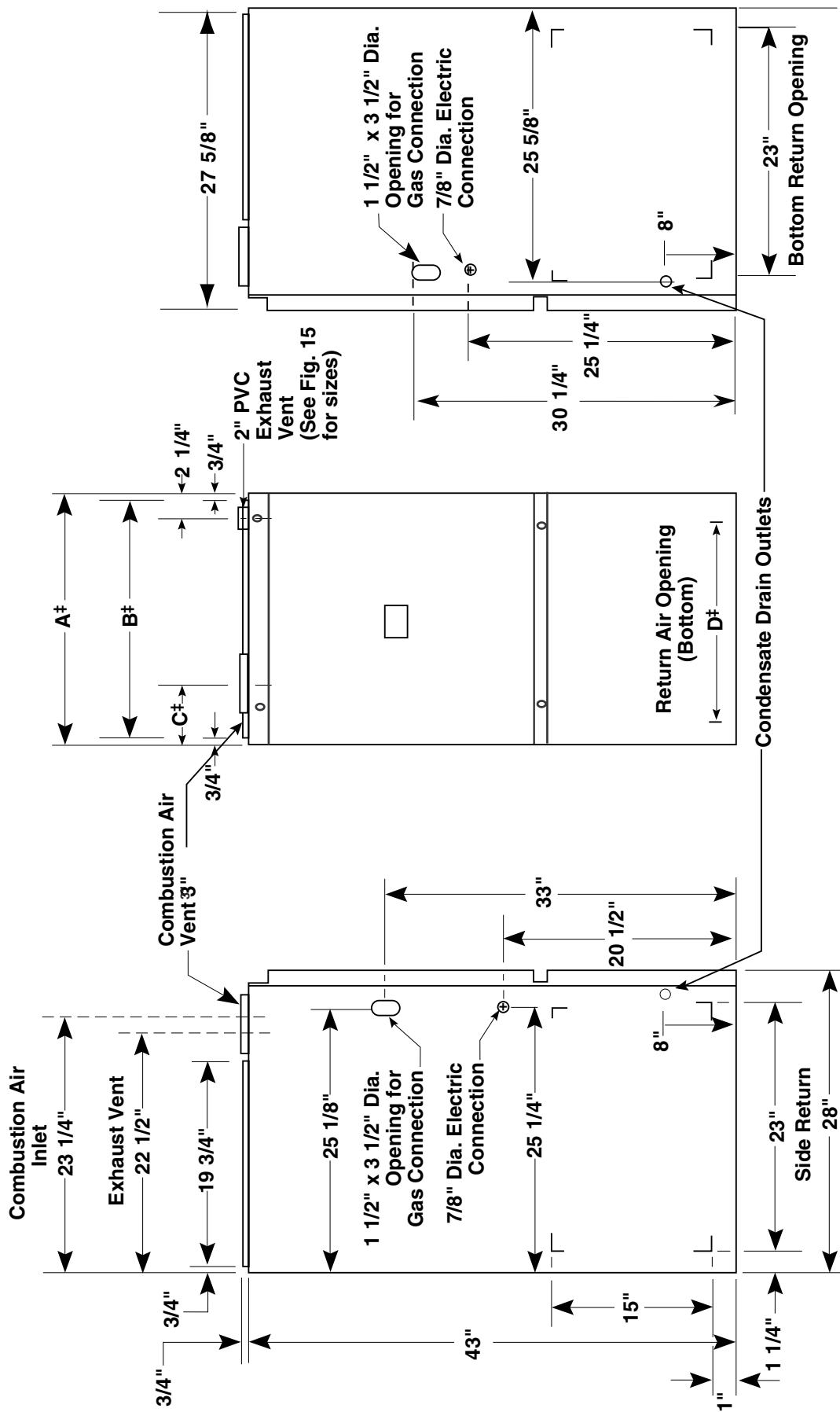

MODEL NUMBER PGF1RC	Dimensions				Shipping Weights (lbs)
	A (in.)	B (in.)	C (in.)	D (in.)	
40,000 A	14 1/4	12 3/4	5 1/8	11 3/4	133
60,000 A	14 1/4	12 3/4	5 1/8	11 3/4	140
80,000 B	19 3/4	18 1/4	7 7/8	17 1/4	172
100,000 B	19 3/4	18 1/4	7 7/8	17 1/4	180
120,000 C	22 1/2	21	9 1/4	20	204

STANDARD EQUIPMENT

Direct vent; draft inducer; pressure switch; redundant main gas control; hot-surface ignition; timed ON/OFF blower controls (TDR); 40VA transformer for air conditioner application; limit controls; direct drive motor; all models can be converted to use L.P. (propane) gas. Factory approved kits only must be used and are available as an optional accessory from your Maytag distributor.

SPECIFICATIONS

PGF1RC MODEL NUMBERS:	040()08A	040()12A	060()12A	080()12B	080()16B	100()16B	100()20B	120()16C	120()20C
Input-Btuh (a)	40,000	40,000	60,000	80,000	80,000	100,000	100,000	120,000	120,000
Heating Capacity - Btuh	36,000	36,000	55,000	72,000	72,000	92,000	92,000	110,000	110,000
AFUE	92.1	92.1	92.1	92.1	92.1	92.1	92.1	92.1	92.1
Blower D x W	10 x 6	10 x 6	10 x 6	10 x 10	10 x 10	10 x 10	11 x 10	10 x 10	11 x 10
Motor H.P. -Speed -Type	1/5 - 3 - PSC	1/3 - 3 - PSC	1/3 - 3 - PSC	1/2 - 4 -PSC	1/2 - 4 -PSC	1/2 - 4 -PSC	3/4 - 4 -PSC	1/2 - 4 -PSC	3/4 - 4 -PSC
Motor FLA	3.0	6.0	6.0	7.9	7.9	7.9	11.1	7.9	11.1
Maximum Ext. SP - In. W.C.	0.5	0.5	0.5	0.5	0.5	0.5	0.5	0.5	0.5
Temperature Rise Range - °F	35 - 65	35 - 65	45 - 75	40 - 70	40 - 70	45 - 75	45 - 75	55 - 85	55 - 85

() Can be C or N

Note: All models are 115V, 60 Hz. Gas Connections are 1/2" N.P.T. AFUE = Annual Fuel Utilization Efficiency

(a) Ratings to 2,000 ft. Over 2,000 ft. reduce 4% for each 1,000 ft. above sea level.

VENTING

All models are approved for non direct (1 pipe) and direct (2 pipe) venting applications. See Vent Table below for specified sizes and allowable lengths.

APPLICATION	SINGLE PIPE LENGTH (ft.) with 1 long radius elbow*		DIRECT VENT, DUAL PIPE LENGTH (ft.) with 1 long radius elbow on each pipe*					
	Outlet	Outlet	Inlet/Outlet		Inlet/Outlet		Inlet/Outlet	
PVC, CPVC or ABS SCH. 40 Pipe Size	2"	3"	2"	2"	3"	2"	3"	3"
Models 040	80	150	40	40	50	50	90	90
Models 060 & 080	60	150	30	30	35	35	90	90
Models 100 & 120	30	150	15	15	25	25	90	90

* NOTE:

1. Subtract 2.5 ft. for each additional 2" elbow and 3.5 ft. for each additional 3" elbow.
2. Two 45 degree elbows are equivalent to one 90 degree elbow.
3. One short radius elbow is equivalent to two long radius elbows.
4. Do not include termination elbows in calculation of vent length.
5. This table is applicable for elevations from sea level to 2000 ft. For higher elevations decrease vent pipe lengths by 8% per 1000 ft. of altitude.
6. Only the listed pipe materials are approved for use with PGF1RC Condensing Furnaces.

VENT KITS

Kit	Order Number
U.S. LP Conversion Kit (0 to 10,000 ft.)	904090A
Canadian LP Gas Conversion Kit (0 to 4,500 ft.)	904091A
Fossil Fuel Kit	914762
Side Return Filter Kit	541036
Bottom Return A Cabinet	903088
Filter (20/Box) B Cabinet	903089
C Cabinet	903090
Horizontal Drain Kit	903568
Internal Side Return Filter Wire	903152
Variable Speed Blower Kit for "A" cabinets	904231
Variable Speed Blower Kit for "B" & "C" cabinets	904075

ACCESSORIES

Kit Description	2" PVC	3" PVC
Horizontal Exterior Vent Mounting Kit	902373	902375
Concentric Vent Kit	904177	904176
Neutralizer Kit (all models)	902377	
Side Wall Vent Kit	904347	

Furnace Input (Btuh)	Cabinet Width (in.)	Nominal Electrical Supply	Maximum Operating Voltage	Minimum Operating Voltage	Maximum on Furnace Amperes	Minimum Wire Gauge	Maximum on Fuse or Circuit Breaker Amps*
40,000	14.25	115-60-1	127	103	7.8	14	15
60,000	14.25	115-60-1	127	103	7.8	14	15
80,000	19.75	115-60-1	127	103	9.7	14	15
100,000	19.75	115-60-1	127	103	9.7	14	15
120,000	22.50	115-60-1	127	103	12.9	12	20

* Time-delay fuses or HACR-type circuit breakers are required.

Thermostat Wire Gauge	Recommended Maximum Thermostat Wire Length	
	2-wire (heating)	4 or 5-wire (cooling)
24	55 ft.	25 ft.
22	90 ft.	45 ft.
20	140 ft.	70 ft.
18	225 ft.	110 ft.

BLOWER PERFORMANCE

Model Number *RC	Heating Input (Btuh)	Motor Speed	Motor HP	External Static Pressure (Inches Water Column)															
				0.1		0.2		0.3		0.4		0.5		0.6		0.7		0.8	
				CFM	Rise	CFM	Rise	CFM	Rise	CFM	Rise	CFM	Rise	CFM	Rise	CFM	Rise	CFM	Rise
040()08A	40,000	High* Medium** Low	1/5	950	36	920	38	890	39	850	41	800	43	750	46	690	50	630	55
				740	47	710	49	680	51	650	53	600	58	550	63	490	-	430	-
				620	56	590	59	560	62	520	-	470	-	410	-	350	-	290	-
040()12A	40,000	High* Medium** Low	1/3	1330	-	1280	-	1230	-	1170	-	1120	-	1030	-	940	37	850	41
				1190	-	1160	-	1110	-	1060	-	1010	-	910	38	820	42	720	48
				830	42	810	43	780	44	760	46	720	48	670	52	610	57	550	63
060()12A	60,000	High* Medium** Low	1/3	1310	-	1260	-	1210	-	1160	45	1100	47	1040	50	980	53	920	56
				1160	45	1120	46	1080	48	1050	49	990	52	940	55	890	58	830	63
				800	65	780	67	760	68	740	70	710	73	680	-	650	-	620	-
080()12B	80,000	High* Med-High** Med-Low Low	1/2	1775	38	1724	39	1652	40	1583	42	1505	44	1430	46	1343	49	1226	54
				1417	47	1385	48	1339	50	1280	52	1224	54	1163	57	1097	61	1013	66
				1031	65	987	67	967	69	914	73	882	75	839	-	783	-	692	-
080()16B	80,000	High* Med-High** Med-Low Low	1/2	1840	-	1780	-	1700	41	1630	42	1550	45	1470	47	1380	50	1290	54
				1600	43	1560	44	1470	47	1400	49	1350	51	1280	54	1210	57	1150	60
				1380	50	1350	51	1300	53	1250	55	1190	58	1120	62	1040	67	960	-
100()16B	100,000	High* Med-High** Med-Low Low	1/2	1910	45	1860	47	1780	49	1700	51	1620	53	1520	57	1420	61	1310	66
				1640	53	1620	53	1540	56	1480	58	1420	61	1340	65	1250	69	1150	75
				1440	60	1410	61	1370	63	1320	66	1270	68	1210	72	1140	-	1060	-
100()20B	100,000	High* Med-High** Med-Low Low	3/4	2195	39	2140	40	2065	41	2000	42	1960	44	1860	46	1780	48	1695	50
				1975	43	1910	44	1875	45	1845	46	1805	47	1735	50	1670	51	1590	53
				1650	51	1615	52	1605	53	1570	54	1540	55	1485	57	1435	59	1370	62
120()16C	120,000	High* Med-High** Med-Low Low	1/2	1860	56	1800	58	1730	60	1650	63	1570	66	1480	70	1380	75	1270	82
				1650	63	1610	65	1550	67	1480	70	1410	74	1320	79	1230	84	1120	-
				1440	72	1410	74	1380	75	1320	79	1280	81	1220	85	1150	-	1080	-
120()20C	120,000	High* Med-High** Med-Low Low	3/4	2260	-	2200	-	2140	-	2070	-	1990	-	1910	-	1810	57	1710	61
				1870	56	1840	56	1790	58	1760	59	1710	61	1660	63	1610	65	1560	67
				1540	67	1530	68	1510	69	1470	71	1430	73	1370	76	1300	80	1220	85
				1360	76	1330	78	1310	79	1280	81	1250	83	1220	85	1190	-		

() Can be C or N

* Factory Set Cooling Speed

** Factory Set Heating Speed

- Not Recommended

NOTES: 1. Airflow rates of 1800 CFM or more require two return air connections. Data is for operation with filter(s).
2. Temperature rises in the table are approximate. Actual temperature rises may vary.
3. Temperature rises and airflows for external static pressures greater than 0.5 are for reference only. These conditions are not recommended.

IDENTIFICATION CODE

P G F 1 R C 120 C 20 C

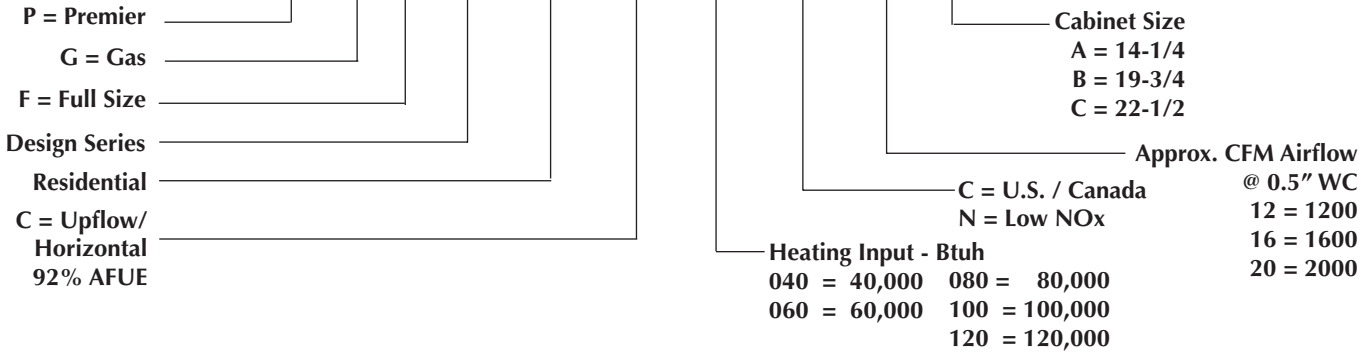

Before purchasing this appliance, read important energy cost and efficiency information available from your retailer. Specifications and illustrations subject to change without notice and without incurring obligations.

Maytag is a registered trademark of the Maytag Corporation and is used under license to NORDYNE Inc.

276B-0107 (Replaces 276B-1106)

Printed in U.S.A. (01/07)