

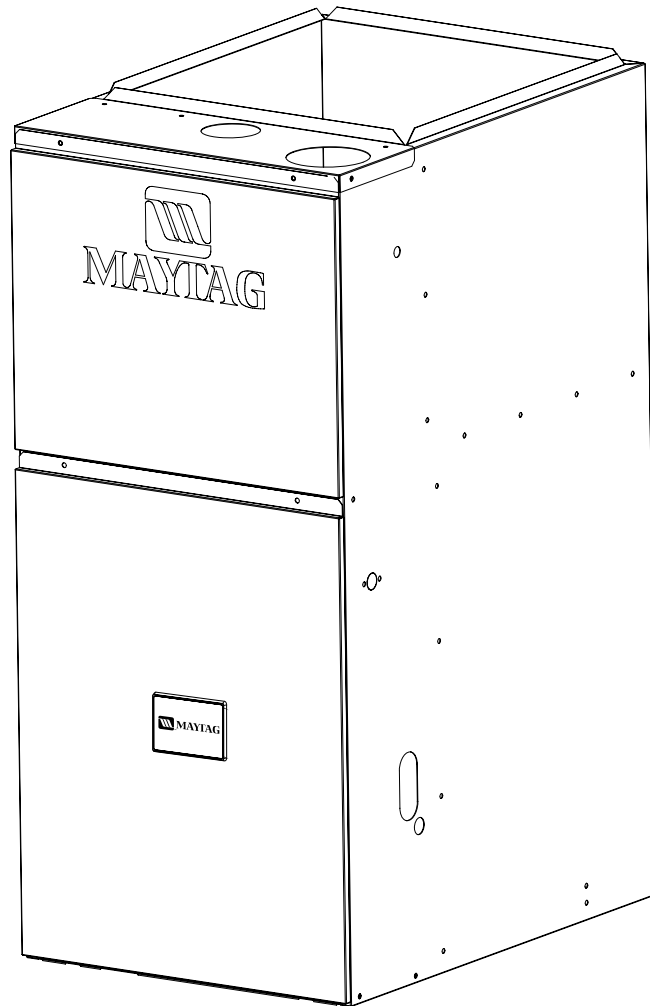

TECHNICAL SPECIFICATIONS

Model PGF1RL Series



M1010 Product Line

**High Efficiency / 92.1 AFUE Direct Vent or
Non Direct Vent Condensing Downflow Gas Furnace**

- **10 YEAR
WARRANTY**
- **WORRY-FREE
PERFORMANCE**
- **5 YEAR
DEPENDABILITY
PROMISE**



The high efficiency downflow gas furnace may be installed free standing in a utility room, or enclosed in an alcove or closet. The extended flush jacket provides a pleasing “appliance appearance.” Design certified by the Canadian Standards Association (CSA). The product is truly designed with the contractor and the consumer in mind.

Features and Benefits

- **Best warranty in the business** —
 - A lifetime warranty on the heat exchanger
 - 10 Year Limited Parts and Labor and 5 Year Dependability Promise
- **100% fired and tested** — All units and each component (both mechanical and electrical) are tested on the manufacturing line.
- **Best packaging in the industry** — Unique design assures product will arrive to the homeowner dent free.
- **Clean and quiet operation** — Due to the unique design of in-shot burners, location of inducer and use of insulation.
- **Fixed 30 second blower delay** at burner start-up assures a warm duct temperature at furnace start-up. Adjustable blower off settings (60, 120, 160 and 180 seconds).
- **Fixed 30-second post purge** increases life of heat exchanger.
- **SmartStart™ Control Board** — Provides extended life to ignitors in furnaces using hot surface ignition technology. Programmed to learn the heat-up characteristics of the ignitor, then adapt the ignition time to the characteristics of the furnace so the ignitor is energized appropriately.
- **Dependable, hot surface ignitor** — Innovative application of an appliance type ignitor with a 20-year history of reliability, assures no call-backs because of handling.
- **Color coded wire harness** — Designed to fit the components, all with quick-connect fittings for ease of service and replacement.
- **Tubular primary heat exchanger** — Heavy gauge aluminized steel heat exchanger assures a long life.
- **Stainless steel** secondary heat exchanger assures a long life.
- **Fixed cooling cycle blower-off delay (TDR)** increases cooling performance when matched with a Maytag coil.
- **Approved for direct vent furnace, category IV venting system** — May be vertically or horizontally vented using either a one-pipe or two-pipe system for maximum flexibility in installation.
- **Fully insulated blower cabinet** for quiet operation.
- **Multi-speed direct drive blower** — Designed to give a wide range of cooling capacities. 40VA transformer included.
- **LP convertible** — Simple burner orifice and regulator spring change for ease of convertibility.
- **Diagnostic light flashes** identify limit failure, pressure switch failure and improper ground and polarization — for easy troubleshooting.
- **Incorporates integrated control board** with connections for electronic air cleaner, humidifier and twinning.
- **Factory installed drain system** — for reliable performance.
- **Door design enhances furnace appearance** and uses screw fasteners for great fit and accessibility.
- **3 amp fuse** protection against low voltage shorts; protects transformer and control board.
- **Low voltage terminal board** for easy field wiring.
- **Components and Controls** — Designing quality into our products means selecting manufacturers that have a reputation for delivering high quality, dependable products.

Multi-speed PSC Motor/ Blower provides quiet airflow, reliable operation and is installed on a slide out track. (Not shown)

SmartStart™ Integrated Control monitors the burner flame and limit circuit continuously. Blower timing has adjustable OFF settings. Provides humidifier and electronic air cleaner connections.

Pressure Switch assures proper operation of the induced draft system.

Vent Switch protects against blocked flue.

Induced Draft Blower provides quiet and reliable operation.

Counterflow Heat Exchanger orientation and aluminized steel tubular design, means improved efficiency and durability. (Not shown)

Supply Air Limit.

Remote flame sensor for proof of flame carry-over. (Not Shown).

Roll-Out Switch.

Aluminized Steel In-shot Burners, Hot Surface Ignitor and Redundant Gas Valve provide safe, reliable ignition and efficient combustion.

Factory Installed drain for reliable performance.

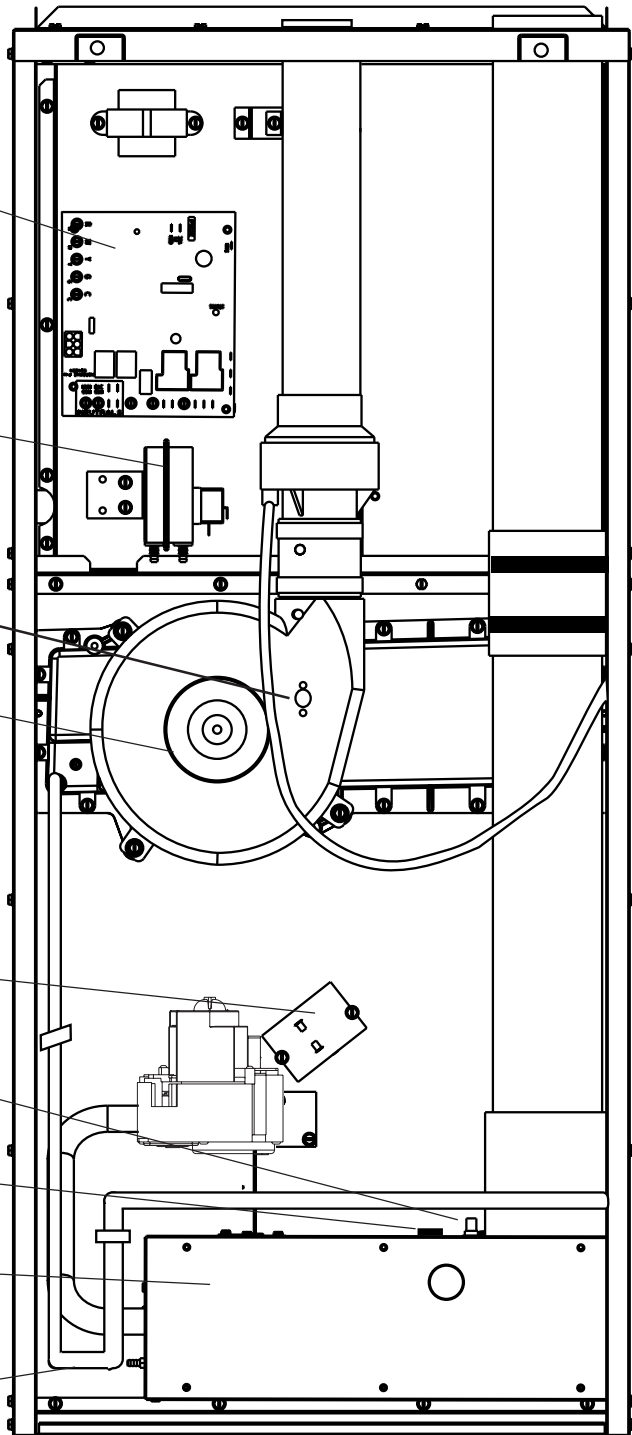

DIMENSIONS

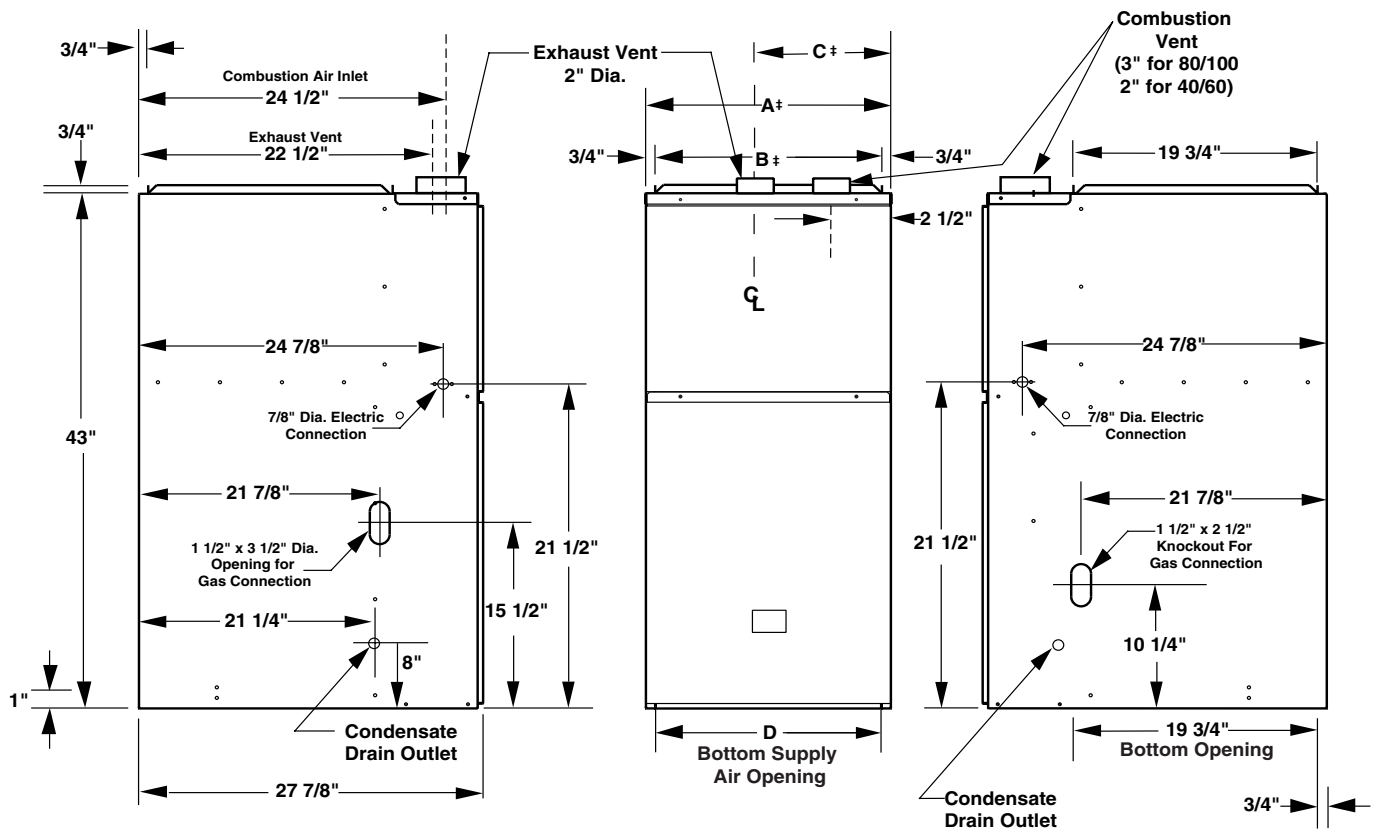

MODEL NUMBER PGF1RL	Furnace Input (Btu/Hr)	Dimensions				Shipping Weights (lbs)
		A (in.)	B (in.)	C (in.)	D (in.)	
040()12A	40,000	14 1/4	12 3/4	4 5/8	11 3/4	135
060()12A	60,000	14 1/4	12 3/4	4 5/8	11 3/4	135
080()16B	80,000	19 3/4	18 1/4	10	17 1/4	174
100()16B	100,000	19 3/4	18 1/4	10	17 1/4	185
120()20C	120,000	22 1/2	21	12 1/2	21 1/8	209

() Can be C or N

Allow 36" minimum clearance for service.

STANDARD EQUIPMENT

Direct vent; draft inducer; pressure switch; redundant main gas control; hot-surface ignition; timed ON/OFF blower controls (TDR); 40VA transformer for air conditioner application; limit controls; direct drive motor; all models can be converted to use L.P. (propane) gas. Factory approved kits only must be used and are available as an optional accessory from your Maytag distributor.

SPECIFICATIONS

PGF1RL MODEL NUMBERS	040()12A	060()12A	080()16B	100()16B	120()20C
Input-Btuh (a)	40,000	60,000	80,000	100,000.00	120,000
Heating Capacity - Btuh	36,000	56,000	74,000	93,000	112,000
AFUE	90+	92.1	92.1	92.1	92.1
Blower D x W	10 x 6	10 x 6	10 x 10	10 x 10	11 x 10
Motor H.P. -Speed -Type	1/3 - 3 - PSC	1/3 - 3 - PSC	1/2 - 4 -PSC	1/2 - 4 -PSC	1/2 - 4 -PSC
Motor FLA	7.0	7.0	9.0	9.0	9.0
Maximum Ext. SP - In. W.C.	0.5	0.5	0.5	0.5	0.5
Temperature Rise Range - °F	35 - 65	40 - 70	45 - 75	50 - 80	50 - 80

() Can be C or N

Note: All models are 115V, 60 Hz. Gas Connections are 1/2" N.P.T. AFUE = Annual Fuel Utilization Efficiency

(a) Ratings to 2,000 ft. Over 2,000 ft. reduce 4% for each 1,000 ft. above sea level.

BLOWER PERFORMANCE

Model Number PGF1RL	Heating Input (Btuh)	Motor Speed	Motor HP	External Static Pressure (Inches Water Column)															
				0.1		0.2		0.3		0.4		0.5		0.6		0.7		0.8	
				CFM	Rise	CFM	Rise	CFM	Rise	CFM	Rise	CFM	Rise	CFM	Rise	CFM	Rise	CFM	Rise
040()12	40,000	High*	1/3	1280	-	1210	-	1180	-	1140	-	1090	-	1070	-	1030	-	990	-
		Medium		1140	-	1090	-	1060	-	1030	-	980	35	950	36	910	37	870	39
		Low**		875	39	835	41	820	41	805	42	780	43	770	44	760	45	750	45
060()12	60,000	High*	1/3	1260	40	1190	43	1155	44	1120	45	1075	47	1030	49	980	52	940	54
		Medium		1120	45	1070	48	1040	49	1010	50	960	53	930	55	890	57	850	60
		Low**		855	59	815	62	800	64	780	65	760	67	730	70	710	-	690	-
080()16	80,000	High*	1/2	1635	-	1585	-	1525	-	1460	46	1400	48	1330	51	1260	54	1180	57
		Med-High		1435	47	1395	49	1350	50	1300	52	1255	54	1200	56	1150	59	1090	62
		Med-Low**		1230	55	1200	56	1165	58	1130	60	1090	62	1050	65	1000	68	960	71
100()16	100,000	High*	1/2	1600	53	1555	54	1500	56	1445	59	1380	61	1310	65	1240	68	1160	73
		Med-High**		1475	57	1435	59	1385	61	1335	63	1290	66	1240	68	1190	71	1130	75
		Med-Low		1320	-	1290	-	1250	-	1215	-	1170	-	1120	-	1070	-	1020	-
120()20	120,000	High*	3/4	2085	48	2034	49	1965	51	1909	52	1842	54	1779	56	1714	58	1631	61
		Med-High**		1924	52	1883	53	1836	55	1781	56	1728	58	1675	60	1613	62	1538	65
		Med-Low		1718	58	1671	60	1629	61	1612	63	1567	64	1510	66	1464	68	1412	72
120()20	120,000	Low	3/4	1501	66	1497	69	1461	66	1428	70	1397	72	1364	73	1316	-	1266	-

() Can be C or N

* Factory Set Cooling Speed

** Factory Set Heating Speed

- Not Recommended

Notes:

1. Airflow rates of 1800 CFM or more require two return air connections. Data is for operation with filter(s).

2. Temperature rises in the table are approximate. Actual temperature rises may vary.

3. Temperature rises and airflows for external static pressures greater than 0.5 are for reference only. These conditions are not recommended.

VENTING

APPLICATION	SINGLE PIPE LENGTH (ft.) with 1 long radius elbow**		DIRECT VENT, DUAL PIPE LENGTH (ft.) with 1 long radius elbow on each pipe**					
	Outlet	Outlet	Inlet/Outlet		Inlet/Outlet		Inlet/Outlet	
	2"	3"	2"	2"	3"	2"	3"	3"
Models PGF1RL 040	80	150	40	40	50	50	90	90
Models PGF1RL 060 & 080	60	150	30	30	35	35	90	90
Models PGF1RL 100 & 120	30	150	15	15	25	25	90	90

* NOTE:

1. Subtract 2.5 ft. for each additional 2" elbow and 3.5 ft. for each additional 3" elbow.
2. Two 45 degree elbows are equivalent to one 90° elbow.
3. One short radius elbow is equivalent to 2 long radius elbows.
4. Do not include termination elbows in calculation of vent length.
5. This table is applicable for elevations from sea level to 2000ft. For higher elevations decrease vent pipe lengths by 8% per 1000 ft. of altitude.
6. Only the above pipe materials are approved for use with these Condensing Furnaces.

ACCESSORY VENT KITS

Kit	Order Number
U.S. LP Conversion Kit (0 to 10,000 ft.)	904090A
Canadian LP Gas Conversion Kit (0 to 4,500 ft.)	904091A
Fossil Fuel Kit	914762
Downflow Sub-Base	A Cabinet 902974 B Cabinet 902677 C Cabinet 904108
Variable Speed Blower Kit For "A" Cabinets	904231
Variable Speed Blower Kit For "B" & "C" Cabinets	904075

Kit Description	2" PVC	3" PVC
Horizontal Exterior Vent Mounting Kit	9023730	9023750
Neutralizer Kit (all models)	9023770	

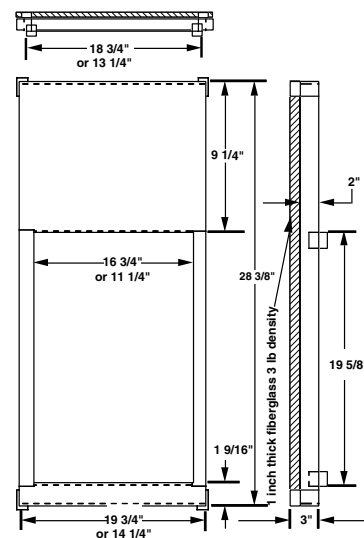

Downflow Sub-base

IDENTIFICATION CODE

P G F 1 R L 120 C 16 B

P = Premier
 G = Gas
 F - Full Size
 Design Series
 Residential
 L = Downflow,
 90% AFUE

Cabinet Width
 A = 14 1/4
 B = 19 3/4
 C = 22 1/2

Approx. CFM Airflow
 @ 0.5" WC
 12 = 1200
 16 = 1600

C = U.S. / Canada
 N = Low NOx

Heating Input - Btuh
 040 = 40,000 080 = 80,000
 060 = 60,000 100 = 100,000
 120 = 120,000



Before purchasing this appliance, read important energy cost and efficiency information available from your retailer. Specifications and illustrations subject to change without notice and without incurring obligations.

Maytag is a registered trademark of the Maytag Corporation and is used under license to NORDYNE Inc.

277B-0506 (Replaces 277B-0604)

Printed in U.S.A. (05/06)