

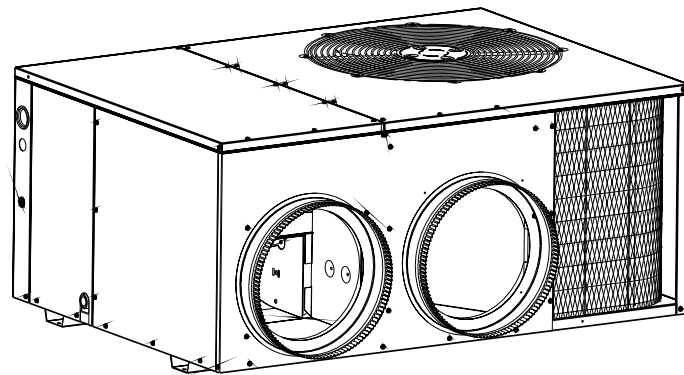

MAYTAG
TM

TECHNICAL SPECIFICATIONS

Model P3RA Series

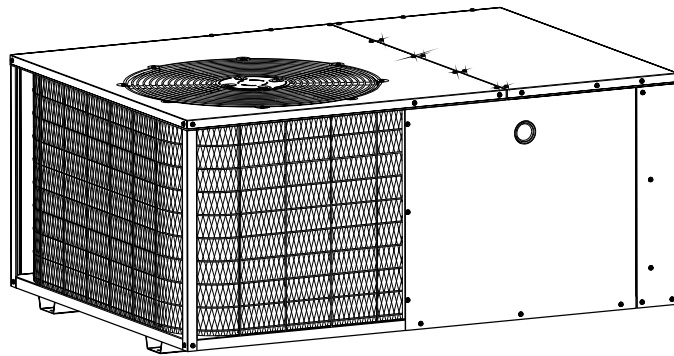

M1000 Product Line

Single Packaged Air Conditioner
10 SEER — 2 - 5 Ton Units

- **10 YEAR
WARRANTY**
- **WORRY-FREE
PERFORMANCE**



The P3 Series single packaged air conditioners are high efficiency self contained cooling and heating units that can be installed on a slab. Units are ETL and ETLc listed. The unit is truly designed with the contractor and the consumer in mind.

Features and Benefits

- **State-of-the-art compressor** is standard equipment.
- **Designed using galvanized steel** with a polyester urethane coat finish. The 950 hour salt spray finish resists corrosion 50% better than comparable units.
- **Both coils** are designed to optimize heat transfer, minimize size and cost, and increase durability and reliability.
- **A heavy duty PSC motor** for long lasting reliability and operation. Requires no maintenance and is completely protected from rain and snow.
- **The service valves are easily accessible** and simplify servicing of the refrigeration system.
- **A wire coil guard and mesh hail guard that will never rust** protects the coil from being damaged by balls, lawnmowers, hail, etc.
- **Designed to make servicing easier** for the contractor, access panels are provided to all major components and the compressor.
- **1" clearance** to combustibles on duct side of the unit allows for installations in tight areas.

- **Easy access** to evaporator for cleaning and general maintenance.
- **Drain trap** design optimizes drainage capabilities.
- **Easy to install** electric heat strip provides up to 20 kw of heat output.
- **Compact footprint and profile** make the P3 Series easy to install and transport.
- **10 Year Residential Parts Warranty**
The best warranty in the business.

DIMENSIONS

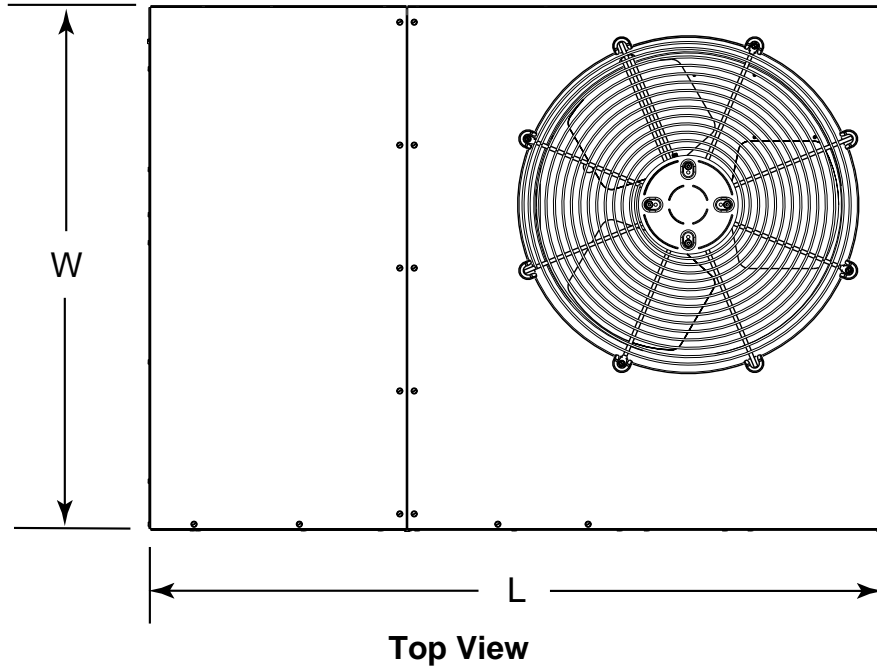

Model No. P3RA-	(L) Length	(W) Width	(H) Height	A	B
024K	49	35	22.2	40.15	7.61
030K	49	35	22.2	35.02	2.48
036K	49	35	22.2	35.02	2.48
042K	49	35	30.2	35.02	2.48
048K	49	35	30.2	40.15	7.61
060K	49	35	30.2	35.02	2.48

Model P3RA-	Return Diameter (in)	Supply Diameter (in)
024K	12	12
030K	12	12
036K	12	12
042K	14	12
048K	14	12
060K	14	12

DIMENSIONS continued

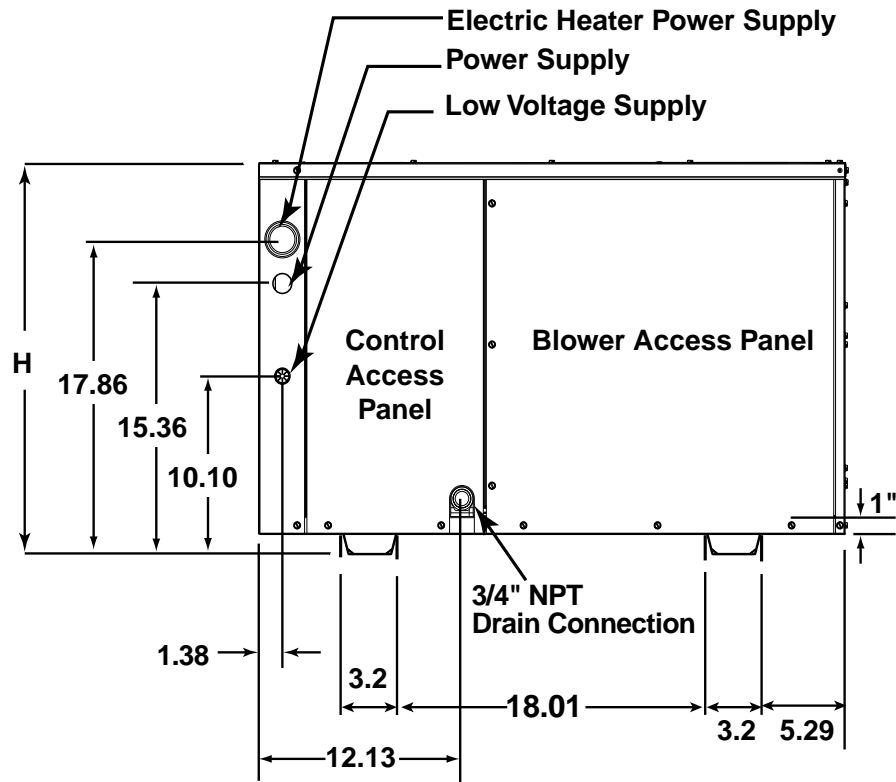

Side View

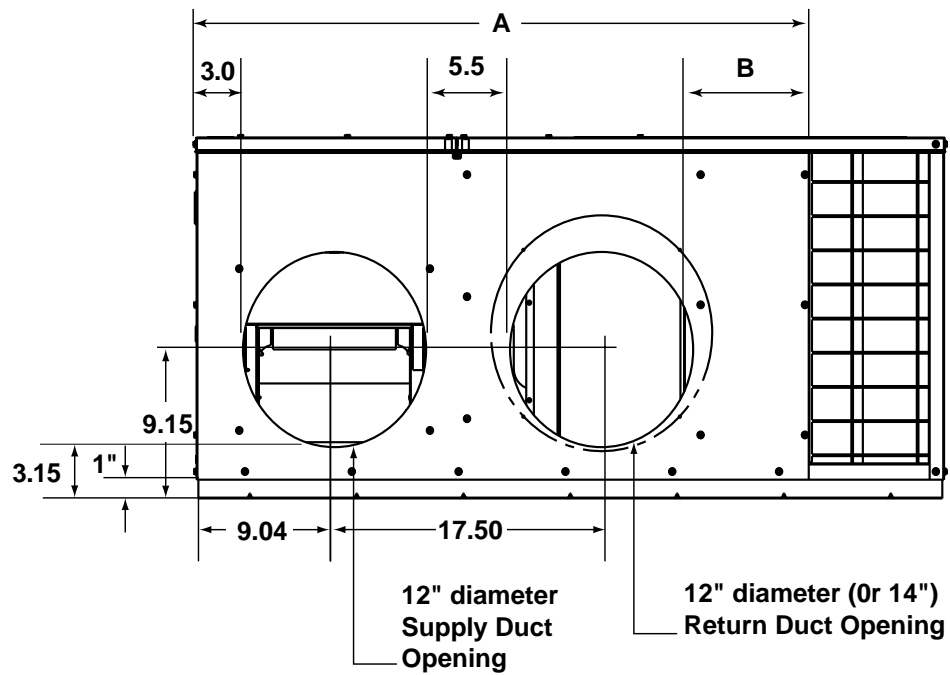

Back (Duct) View

ELECTRICAL DATA

Model Number	Heater Installed (Nom. KW)	Single Supply Circuit Option										Multiple Supply Circuit Option					
		Circuit A					Circuit B					Circuit A			Circuit B		
		Minimum Circuit Amp.	Rec Wire Gauge (60°C Cu)	Rec Wire Gauge (75°C Cu)	Rec Wire Gauge (90°C Cu)	Maximum Over-current Rating*	Minimum Circuit Amp.	Rec Wire Gauge (60°C Cu)	Rec Wire Gauge (75°C Cu)	Rec Wire Gauge (90°C Cu)	Maximum Over-current Rating	Minimum Circuit Amp.	Rec Wire Gauge (60°C Cu)	Rec Wire Gauge (75°C Cu)	Rec Wire Gauge (90°C Cu)	Maximum Over-current Rating	
P3RA-024K	0	14.9	14	14	20	-	-	-	-	-	-	-	-	-	-		
	5	26.8	10	10	30	-	-	-	-	-	-	-	-	-	-		
	8	41.3	6	8	45	-	-	-	-	-	-	-	-	-	-		
	10	51.8	6	8	60	-	-	-	-	-	-	-	-	-	-		
P3RA-030K	0	20.4	10	10	30	-	-	-	-	-	-	-	-	-	-		
	5	27.6	10	10	30	-	-	-	-	-	-	-	-	-	-		
	8	42.2	6	8	45	-	-	-	-	-	-	-	-	-	-		
	10	52.6	6	8	60	-	-	-	-	-	-	-	-	-	-		
P3RA-036K	0	21.8	10	10	35	50	6	8	8	60	27.6	10	10	10	30		
	5	27.6	10	10	35	-	-	-	-	-	-	-	-	-	-		
	8	42.2	6	8	45	-	-	-	-	-	-	-	-	-	-		
	10	52.6	6	8	60	-	-	-	-	-	-	-	-	-	-		
P3RA-042K	0	25.8	10	10	40	50	6	8	8	60	27.6	10	10	10	30		
	5	27.6	10	10	40	-	-	-	-	-	-	-	-	-	-		
	8	42.2	6	8	45	-	-	-	-	-	-	-	-	-	-		
	10	52.6	6	8	60	50.0	6	8	8	60	27.6	10	10	10	30		
P3RA-048K	0	102.6	1	2	110	50.0	6	6	6	60	52.6	6	6	8	60		
	5	31.6	8	8	50	-	-	-	-	-	-	-	-	-	-		
	8	43.3	6	8	50	-	-	-	-	-	-	-	-	-	-		
	10	53.8	6	8	60	-	-	-	-	-	-	-	-	-	-		
P3RA-060K	0	103.8	1	2	110	53.8	6	6	6	60	53.8	6	6	8	60		
	5	38.1	8	8	60	-	-	-	-	-	-	-	-	-	-		
	8	43.3	6	8	60	-	-	-	-	-	-	-	-	-	-		
	10	53.8	6	8	60	53.8	6	6	8	60	28.8	10	10	10	30		
P3RA-060K	0	103.8	1	2	110	53.8	6	6	6	60	53.8	6	6	8	60		
	5	38.1	8	8	60	-	-	-	-	-	-	-	-	-	-		
	8	43.3	6	8	60	-	-	-	-	-	-	-	-	-	-		
	10	53.8	6	8	60	53.8	6	6	8	60	28.8	10	10	10	30		
P3RA-060K	0	103.8	1	2	110	53.8	6	6	6	60	53.8	6	6	8	60		
	5	38.1	8	8	60	-	-	-	-	-	-	-	-	-	-		
	8	43.3	6	8	60	-	-	-	-	-	-	-	-	-	-		
	10	53.8	6	8	60	53.8	6	6	8	60	28.8	10	10	10	30		

*When overcurrent rating exceeds 60, internal circuit breakers must be installed in addition to branch circuit protection at distribution panel.

HEATER APPLICATION MATRIX

Model Number	Motor Speed	H3HK-005H-01A	H3HK-008H-01A	H3HK-010H-01A	H3HK-015H-01A	H3HK-020H-01A	H3HK-015H-21A	H3HK-020H-21A
		917166A	917167A	917168A	917169A	917170A	917172A	917173A
024K	High	X(0)	X(0)	X(0)	NA	NA	NA	NA
	Low	X(0)	X(0)	X(0)	NA	NA	NA	NA
	High	X(0)	X(0)	X(0)	X(2)	NA	X(0)	NA
030K	Low	X(0)	X(0)	X(0)	X(2)	NA	X(0)	NA
	High	X(0)	X(0)	X(0)	X(2)	NA	X(0)	NA
	Low	X(0)	X(0)	X(0)	X(2)	NA	X(0)	NA
036K	High	X(0)	X(0)	X(0)	X(2)	NA	X(0)	NA
	Low	X(0)	X(0)	X(0)	X(2)	NA	X(0)	NA
	High	X(0)	X(0)	X(0)	X(2)	X(3)	X(0)	X(1)
042K	Low	X(0)	X(0)	X(0)	X(2)	X(3)	X(0)	X(1)
	High	X(0)	X(0)	X(0)	X(2)	X(3)	X(0)	X(1)
	Low	X(0)	X(0)	X(0)	X(2)	X(3)	X(0)	X(1)
048K	High	X(0)	X(0)	X(0)	X(2)	X(3)	X(0)	X(1)
	Low	X(0)	X(0)	X(0)	X(2)	X(3)	X(0)	X(1)
	High	X(0)	X(0)	X(0)	X(2)	X(3)	X(0)	X(1)
060K	Low	X(0)	X(0)	X(0)	X(2)	X(3)	X(0)	X(1)
	High	X(0)	X(0)	X(0)	X(2)	X(3)	X(0)	X(1)
	Low	X(0)	X(0)	X(0)	X(2)	X(3)	X(0)	X(1)

NA = Not Approved

() = Number of internal circuit breaker kits required.

HEATER KIT ACCESSORIES

Description	Part Number
4-Pole single circuit adaptor	913350
6-Pole single circuit adaptor	913556
Circuit Breaker Single Phase (2-pole)	913554

IDENTIFICATION CODE

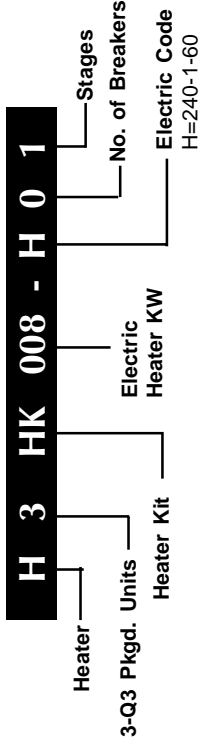

IDENTIFICATION CODE

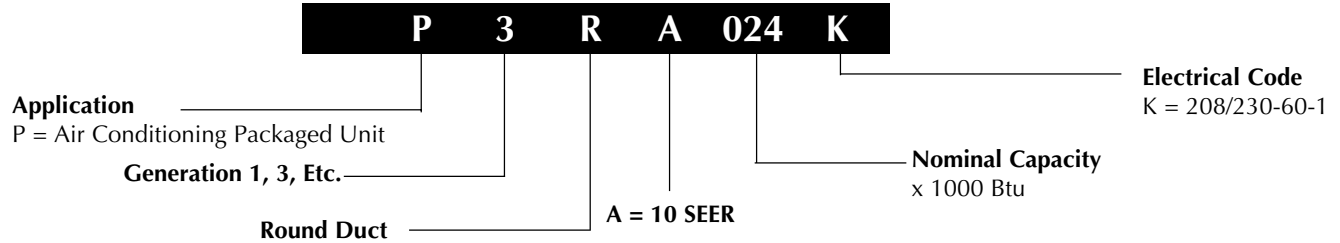

PHYSICAL SPECIFICATIONS

Model No. P3RA-	024K	030K	036K	042K	048K	060K
Electric Rating — 60 Hz (a)						
Operating Voltage Range	187 - 253	187 - 253	187 - 253	187 - 253	187 - 253	187 - 253
Minimum Circuit Ampacity (a)	14.9	20.4	21.8	25.8	31.6	38.1
Field Wire Size — AWG (a)	14	10	10	10	8	8
Delay Fuse — Maximum (b)	20	30	35	40	50	60
Total Unit — AMPS	12.4	17.0	18.1	21.3	26.1	31.3
Compressor						
Volts	208 - 230	208 - 230	208 - 230	208 - 230	208 - 230	208 - 230
Rated Load Amps	9.8	13.7	14.8	17.9	21.8	27.0
Lock Rotor Amps	56.0	75.0	96.0	103.0	131.0	144.0
Fan Motor and Condenser						
Fan Motor — HP - RPM	1/4 - 1100	1/4 - 1100	1/4 - 1100	1/3 - 1100	1/3 - 1100	1/3 - 1100
Fan Motor — Amps	1.2	1.2	1.2	1.3	1.3	1.3
Fan Dia. — CFM	20" - 2800	20" - 2800	20" - 2800	20" - 3000	20" - 3000	20" - 3000
Motor and Evaporator						
Blower Motor — HP - RPM	1/4 - 980	1/3 - 1080	1/3 - 900	1/3 - 900	1/2 - 1000	1/2 - 1000
Blower Motor — Amps	1.4	2.1	2.1	2.1	3	3
CFM @ E.S.P. — in. W.C.	1000 @ .30	1320 @ .30	1390 @ .30	1390 @ .30	1730 @ .30	1680 @ .30
Refrigerant — Oz.	55	56	63	64	86	128
Shipping Weight -- Lbs.	275	280	280	285	325	375

(a) Amperage and wire size based on refrigeration system only. See Electrical Data tables for supplemental electric heaters. Refer to National Electric Code for additional derating factors for field installed conductors.

(b) Use time delay fuse or "HACR" type circuit breaker.

SYSTEM COOLING CAPACITIES

Model Number P3RA-	Cooling Btuh	SEER
024K	24,000	10
030K	30,000	10
036K	35,400	10
042K	40,500	10
048K	47,500	10
060K	59,000	10

BLOWER PERFORMANCE

Model Number		External Static Pressure (in. WC)					
P3RA-		0.1	0.2	0.3	0.4	0.5	0.6
024K	High	1120	1060	1000	930	860	750
	Low	840	800	760	710	610	N/A
030K	High	1450	1380	1320	1240	1150	1050
	Low	1070	1050	1030	980	930	N/A
036K	High	1480	1440	1390	1330	1270	1190
	Low	1270	1230	1190	1140	1080	1000
042K	High	1480	1430	1390	1330	1270	1190
	Low	1270	1220	1180	1140	1080	1010
048K	High	1840	1780	1730	1650	1580	1500
	Low	1700	1650	1590	1540	1470	1390
060K	High	1800	1740	1680	1620	1540	1470
	Low	1660	1610	1560	1500	1430	1360

COPPER WIRE SIZE — AWG (1% Voltage Drop)				
Supply Wire Length-Feet				Supply Circuit
200	150	100	50	Ampacity
6	8	10	14	15
4	6	8	12	20
4	6	8	10	25
4	4	6	10	30
3	4	6	8	35
3	4	6	8	40
2	3	4	6	45
2	3	4	6	50

Wire Size based on N.E.C. for 60° type copper conductors.



We Encourage Professionalism



Before purchasing this appliance, read important energy cost and efficiency information available from your retailer. Specifications and illustrations subject to change without notice and without incurring obligations.

Maytag is a registered trademark of the Maytag Corporation and is used under license to NORDYNE Inc.

301B-0303 (Replaces 301B-0802)

Printed in U.S.A. (03/03)