

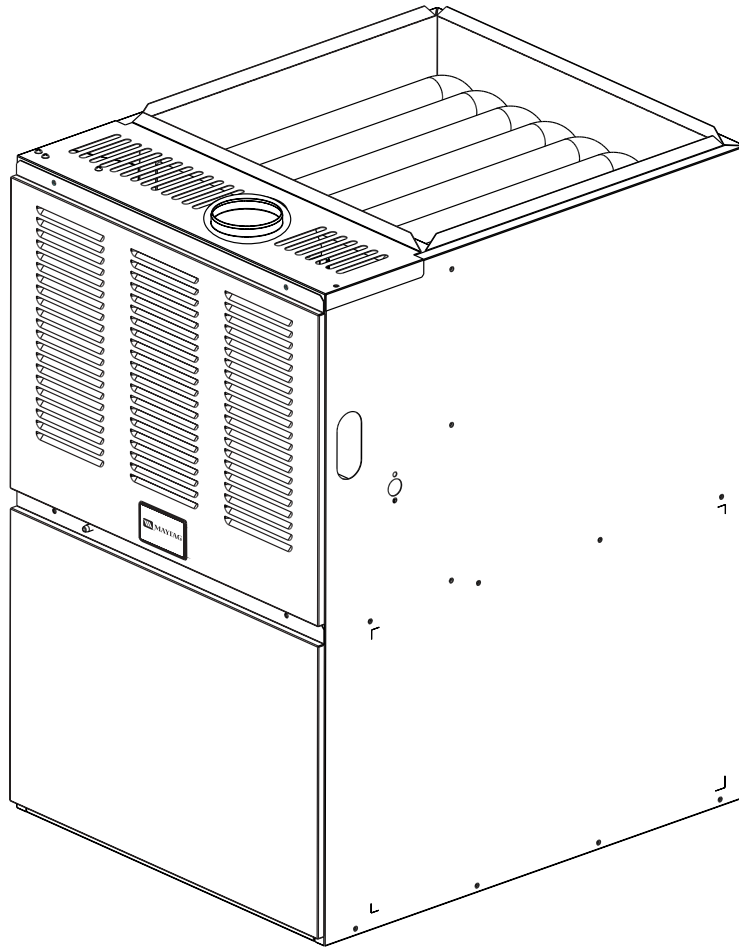

TECHNICAL SPECIFICATIONS

Model MGC1RA Series



M1000 Product Line

**Upflow/Horizontal Gas Furnace
80+ AFUE**

- **10 YEAR
WARRANTY**
- **WORRY-FREE
PERFORMANCE**



The upflow/horizontal gas furnace may be installed free standing in a utility room, basement, or enclosed in an alcove or closet. The extended flush jacket provides a pleasing "appliance appearance." The product is truly designed with the contractor and the consumer in mind.

Features and Benefits

Best warranty in the business —

- A 20 Year warranty on the heat exchanger
- 10 Year Limited Parts
- **100% fired and tested** — All units and each component (both mechanical and electrical) are tested on the manufacturing line.
- **Best packaging in the industry** — Unique design assures product will arrive to the homeowner dent free.
- **Clean and quiet operation** — Due to the unique design of in-shot burners, location of inducer and use of insulation.
- **Fixed 30 second blower delay** at burner start-up assures a warm duct temperature at furnace start-up. Adjustable blower off settings (60, 120, 160 and 180 seconds).
- **Fixed 30-second post purge** increases life of heat exchanger.
- Dependable, hot surface igniter — Innovative application of an appliance type igniter with a 20-year history of reliability, assures no call-backs because of handling.
- **Color coded wire harness** — Designed to fit the components, all with quick-connect fittings for ease of service and replacement.
- **Approved for category I venting system** — May be common or dedicated vented for flexibility in installation.
- **Tubular primary heat exchanger** — Heavy gauge aluminized steel heat exchanger assures a long life.
- **SmartStart® Control Board** — provides extended life to igniters programmed to learn the heat-up characteristics of the igniter so the ignition timing is energized appropriately.
- **Fixed cooling cycle blower-off delay (TDR)** increases cooling performance when matched with a Maytag coil.
- **Furnace is easy to handle** — short and lightweight.
- **Fully insulated blower cabinet** for quiet operation.
- **Multi-speed direct drive blower** — Designed to give a wide range of cooling capacities. 40VA transformer included.
- **LP convertible** — Simple burner orifice and regulator spring change for ease of convertibility.
- **Diagnostic lights flash to identify limit failure, pressure switch failure, improper ground and polarization, and low flame signal** — for easy troubleshooting.
- **Two piece door design** enhances furnace appearance and uses screw fasteners for easier accessibility.
- **3 amp fuse** protection against low voltage shorts; protects transformer and control board.
- **Low voltage terminal board** for easy field wiring.

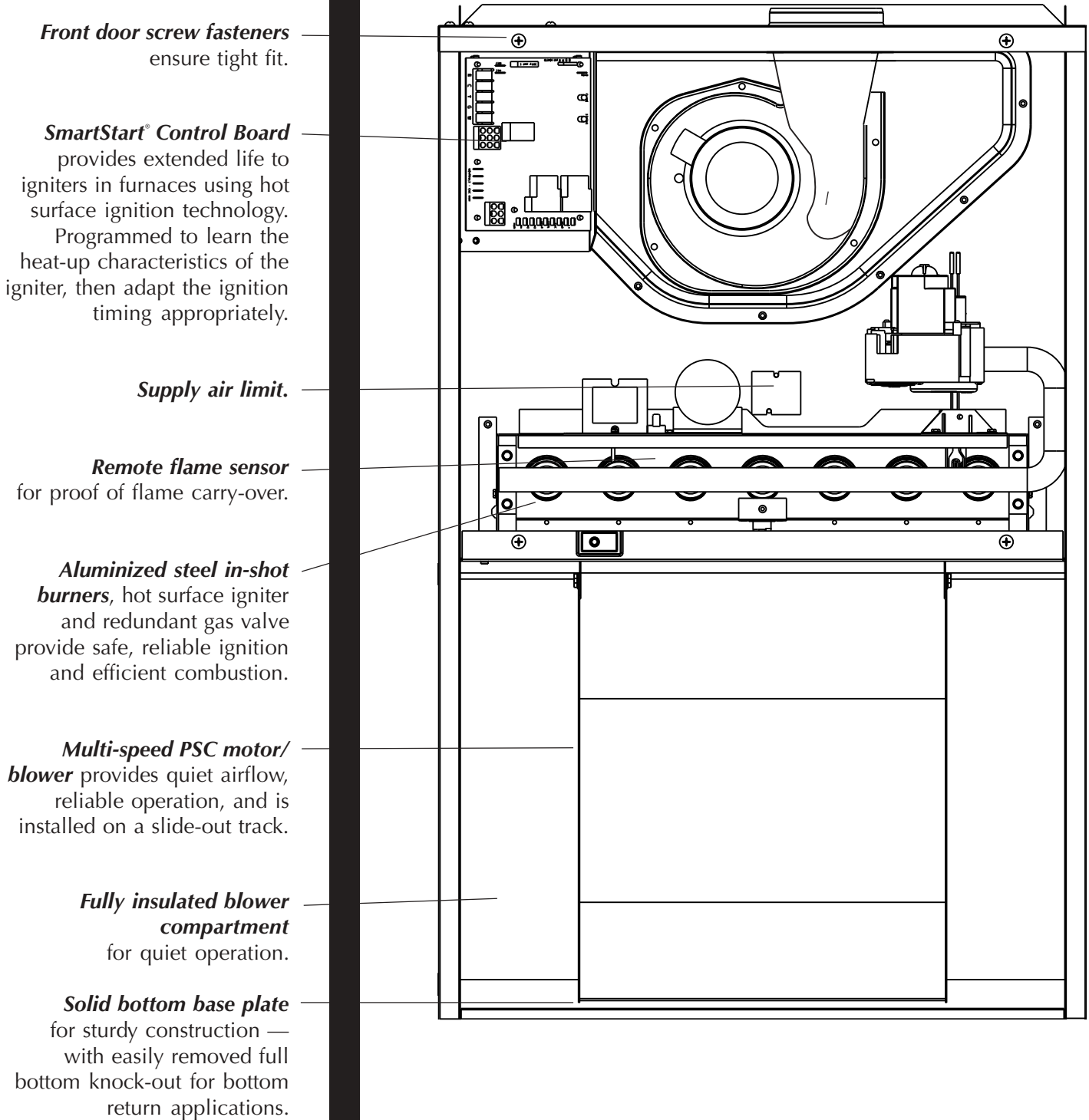

STANDARD EQUIPMENT

Draft inducer; pressure switch; redundant main gas control; hot-surface ignition; timed ON/OFF blower controls (TDR); 40VA transformer for air conditioner application; limit controls; solid base plate with knock-out for easy removal; direct drive motor; all models can be converted to use L.P. (propane) gas. Factory approved kits *only* must be used and are available as an optional accessory from your distributor.

SPECIFICATIONS

MGC1RA MODEL NUMBERS	045(*)08A	054(*)12A	072(*)12A	072(*)12B	072(*)16B	090(*)12B	090(*)16B	108(*)16B	108(*)20C	126(*)20C
Input-Btuh (a)	45,000	54,000	72,000	72,000	72,000	90,000	90,000	108,000	108,000	126,000
Heating Capacity - Btuh	36,000	43,000	58,000	58,000	58,000	72,000	72,000	86,000	86,000	101,000
AFUE	80+	80+	80+	80+	80+	80+	80+	80+	80+	80+
Max. Htg. Ext. St. Press. In W.C.	.5	.5	.5	.5	.5	.5	.5	.5	.5	.5
Blower Wheel D x W	10 x 6	10 x 6	10 x 6	9 x 9	10 x 10	9 x 9	10 x 10	11 x 10	11 x 10	11 x 10
Motor H.P. -Speed -Type	1/5-2-PSC	1/3-3-PSC	1/3-3-PSC	1/4-3-PSC	1/2-4-PSC	1/4-3-PSC	1/2-4-PSC	1/2-2-PSC	3/4-4-PSC	3/4-4-PSC
Motor FLA	4.0	6.0	6.0	6.0	8.8	6.0	8.8	8.8	10.1	10.1
Temperature Rise Range - °F	40 - 70	40 - 70	40 - 70	40 - 70	40 - 70	40 - 70	40 - 70	40 - 70	40 - 70	40 - 70

*Can be C or N.

All models are 115 V, 60 Hz. Gas connections are 1/2" N.P.T.

AFUE = Annual Fuel Utilization Efficiency.

(a) Ratings to 2,000 feet. Over 2,000 feet, reduce 4% for each 1,000 ft. above sea level.

VENTING

All models may be common vented with a gas water heater. Type B gas vent materials may be used when connected to a vertical vent system. The installation must be in accordance with the venting instructions supplied with the furnace.

ACCESSORIES

High Efficiency with Honeywell VR Gas Valve		
Kit		Order Number
U.S. LP Conversion Kit (0 to 10,000 ft.)		904090A
Canadian LP Gas Conversion Kit (0 to 4,500 ft.)		904091A
Fossil Fuel Kit		914762
External Side Return Filter Frame		541036
Bottom Return	A Cabinet	903088
Filter 20/Box	B Cabinet	903089
	C Cabinet	903090
Internal Side Return Filter Retainers 10/Box		903152
High Altitude Pressure Switch Kit (5,001 to 10,000 ft.)		903853

BLOWER PERFORMANCE

MODEL NUMBER MGCT1RA	HEATING INPUT	MOTOR SPEED	MOTOR HP	EXTERNAL STATIC PRESSURE (INCHES OF WATER COLUMN)															
				0.1		0.2		0.3		0.4		0.5		0.6		0.7		0.8	
				CFM	Rise	CFM	Rise	CFM	Rise	CFM	Rise	CFM	Rise	CFM	Rise	CFM	Rise	CFM	Rise
045-08A	40,000	HIGH* LOW**	1/5	1000 760	33 43	970 740	34 44	950 730	35 45	920 720	36 46	870 690	38 48	820 670	41 49	770 640	43 52	700 620	47 53
054-12A	54,000	HIGH* MEDIUM LOW**	1/3	1300 1150 790	31 34 50	1260 1120 780	32 35 50	1210 1090 770	33 36 51	1160 1050 750	34 38 53	1110 1000 720	35 40 55	1050 950 690	38 42 57	980 890 650	40 44 61	910 830 600	44 48 66
072-12A	72,000	HIGH* MEDIUM LOW**	1/3	1380 1220 820	38 43 64	1350 1190 800	39 44 66	1310 1160 780	40 45 68	1260 1120 760	42 47 69	1210 1070 730	44 49 73	1150 1020 700	46 52 76	1080 950 670	49 55 79	1000 880 640	53 60 83
072-12B	72,000	HIGH* MEDIUM LOW**	1/4	1550 1380 1030	34 41 52	1500 1310 1030	35 41 52	1440 1240 1010	37 44 53	1360 1200 980	40 44 54	1280 1140 930	42 47 57	1190 1090 860	45 49 62	1080 970 780	49 55 69	970 870 670	55 61 80
072-16B	72,000	HIGH* MED-HIGH* MED-LOW** LOW	1/2	1955 1635 1370 1165	26 32 40 46	1945 1615 1365 1160	27 33 40 46	1920 1590 1350 1150	27 33 40 46	1890 1570 1340 1130	28 34 41 47	1845 1550 1305 1110	29 35 42 48	1785 1500 1270 1075	30 36 43 49	1700 1440 1230 1030	31 37 44 51	1605 1370 1150 975	33 40 46 55
090-12B	90,000	HIGH* MEDIUM LOW**	1/4	1550 1380 1030	42 52 64	1500 1310 1030	44 55 64	1440 1240 1010	46 58 65	1360 1200 980	48 55 67	1280 1140 930	51 58 72	1190 1090 860	55 64 78	1080 970 780	61 68 85	970 870 670	68 76 99
090-16B	90,000	HIGH* MED-HIGH** MED-LOW LOW	1/2	1985 1635 1410 1210	33 41 47 55	1955 1640 1400 1195	34 41 47 55	1905 1610 1380 1180	35 42 48 56	1855 1575 1355 1160	36 42 49 57	1790 1545 1320 1135	37 43 50 59	1705 1490 1290 1100	40 45 52 60	1630 1430 1240 1060	41 47 54 63	1530 1350 1175 1010	44 49 57 66
090-20B	90,000	HIGH* MED-HIGH MED-LOW LOW**	3/4	2375 1975 1640 1365	28 33 40 49	2320 1955 1615 1345	29 34 41 50	2280 1920 1595 1330	30 35 41 50	2215 1895 1575 1315	30 35 42 51	2150 1850 1540 1280	31 36 43 52	2085 1800 1500 1245	32 37 44 53	2015 1740 1460 1225	33 38 46 54	1940 1685 1400 1210	34 39 48 55
108-16B	108,000	HIGH* MED-HIGH** MED-LOW LOW	1/2	1985 1635 1410 1210	40 49 57 66	1955 1640 1400 1195	41 49 57 67	1905 1610 1380 1180	42 50 58 68	1855 1575 1355 1160	43 51 59 69	1790 1545 1320 1135	45 52 60 70	1705 1490 1290 1100	47 54 62 73	1630 1430 1240 1060	49 56 65 75	1530 1350 1175 1010	52 59 68 79
108-20B	108,000	HIGH* MED-HIGH MED-LOW LOW**	3/4	2410 2035 1680 1435	32 39 47 55	2370 1995 1660 1430	33 40 48 55	2330 1965 1650 1425	34 41 49 56	2275 1955 1645 1415	35 41 49 56	2230 1915 1640 1400	36 42 50 57	2165 1895 1565 1350	37 42 51 59	2075 1815 1550 1330	38 44 52 60	1990 1790 1485 1275	40 45 54 62
108-20C	108,000	HIGH* MED-HIGH** MED-LOW LOW	3/4	2270 1880 1565 1325	35 42 50 60	2210 1865 1550 1320	36 43 51 61	2190 1835 1535 1315	36 43 52 61	2165 1815 1520 1310	37 44 52 61	2130 1790 1510 1285	38 45 53 62	2100 1770 1495 1275	39 45 54 63	2030 1755 1455 1250	40 46 55 64	1975 1720 1420 1220	41 47 56 66
126-20C	126,000	HIGH* MED-HIGH** MED-LOW LOW	3/4	2270 1880 1565 1325	40 49 59 70	2210 1865 1550 1320	41 50 60 70	2190 1835 1535 1315	42 51 61 71	2165 1815 1520 1310	43 51 61 71	2130 1790 1510 1285	44 52 62 72	2100 1770 1495 1275	45 52 63 73	2030 1755 1455 1250	46 53 64 75	1975 1720 1420 1220	47 54 66 76

- * Factory Set Cooling Speed
- ** Factory Set Heating Speed
- Not Recommended

Notes:

1. Airflow rates of 1800 CFM or more require two return air connections. Data is for operation with filter(s).
2. Temperature rises in the table are approximate. Actual temperature rises may vary.
3. Temperature rises and airflows for external static pressures greater than 0.5 are for reference only. These conditions are not recommended.

