

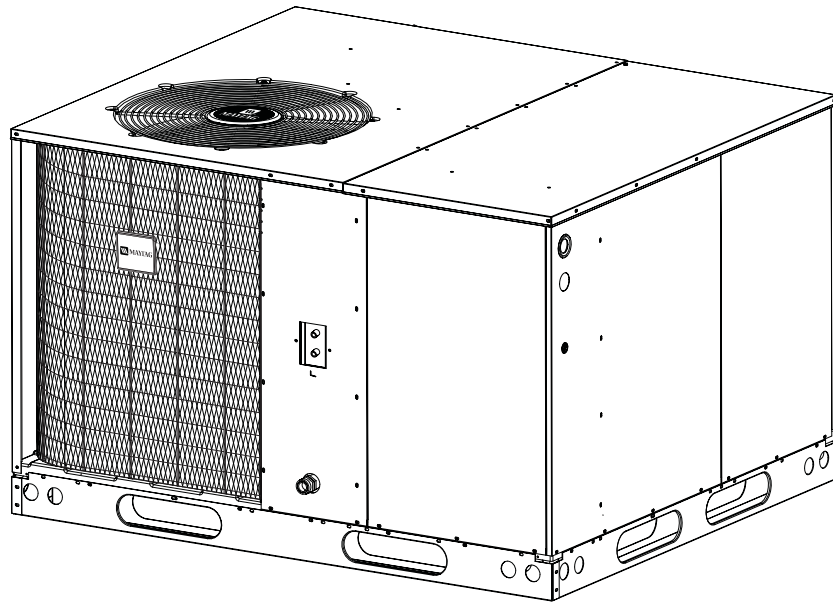

TECHNICAL SPECIFICATIONS

Model Q4SE Series



M1000 Product Line

**Single Packaged Heat Pump
14 SEER - 3 – 5 Ton Units**

- **10 YEAR
WARRANTY**
- **WORRY-FREE
PERFORMANCE**



The Q4SE Series single packaged heat pumps are high efficiency self contained cooling and heating units that can be installed on a roof or on a slab. The convertible unit design makes installations simple in all applications. Units are ETL and ETLc listed.

Features and Benefits

- **Copeland Ultra-Tech Compressor**
Two stage heat/cool.
- **Compact Footprint/Low Profile**
Easy to handle and transport.
- **Heavy-Gauge, Full Perimeter Base Rails**
Facilitates forklift handling and curb mounting.
- **Hi/Low Pressure Switches**
Added compressor protection.
- **Convertible Air Delivery**
Horizontal or downflow to accommodate rooftop or horizontal application.
- **R-410A Refrigerant**
Environmentally friendly.
- **Galvanized Steel Cabinet**
Unit is trimmed in a silicone-protected polyester finish with a 950 hour salt spray finish that resists corrosion 50% better than comparable units.
- **Plastic Coated Coil Guard and Mesh Hail Guard**
Will never rust and protects the coil from being damaged by balls, lawnmowers, hail etc.
- **Externally Accessible Service Ports**
Quick access to refrigerant system without disrupting operation.
- **Access to Controls and Major Components**
Easy in and out service.
- **Corrosion-Resistant Drain Pan**
Quickly drains away evaporator condensate.
- **Service Access Panels**
Allows easy access to all major components and the compressor. Designed to make servicing easier for the Contractor.
- **Easy to Install**
Electric heat strip provides up to 20 KW of heat output.
- **Proven, Industry Standard Components**
Easier service and availability.
- **Demand Defrost Standard**
Provides additional energy savings in heating by defrosting only when necessary.
- **ECM Variable Speed Motor**
Advanced technology allows the motor to automatically adjust to different static loads. The variable speed motor allows for extra quiet operation and improved air quality.
- **Quiet Operation and Low Vibration**
20" fan blade combined with custom venturi condenser fan. Compressor sound blanket for ultra-high operation.
- **10 Year Residential Parts Warranty**
The best warranty in the business.

IDENTIFICATION CODE

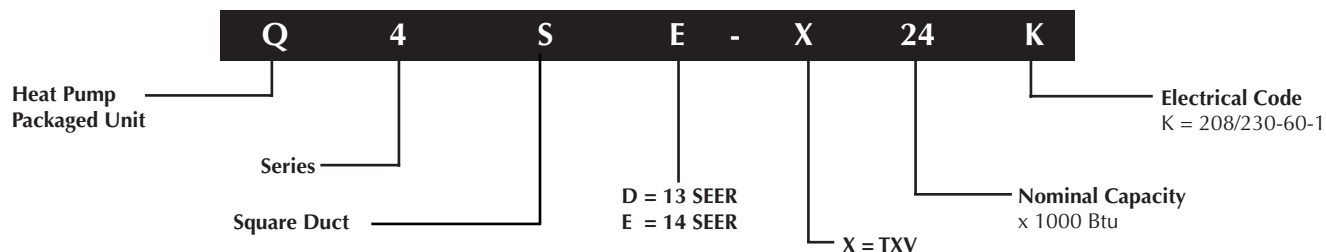

SPECIFICATIONS

Model Number	Q4SE		
	-X36K	-X48K	-X60K
Performance			
Capacity - Heating BTUH	33,000	42,500	54,500
Efficiency - HSPF	8.0	8.0	8.0
Capacity - Cooling BTUH	34,000	44,000	56,500
Efficiency - SEER	14.00	14.50	14.00
EER (Btuh/watt)	11.0	11.0	11.0
Electrical Rating - 60 Hz			
Phase	1	1	1
Operating Voltage Range	187-253	187-253	187-253
Compressor Data			
Volts	208-230	208-230	208-230
Rated Load Amps	19.0	24.0	26.0
Lock Rotor Amps	82	96	118
Indoor Blower			
Type	Var. Sp.	Var. Sp.	Var. Sp.
Motor HP	1/2	3/4	3/4
Motor RPM Range	490-740	645-950	645-950
Motor - Amps	4.3	6.8	6.8
Outdoor Fan			
Motor - HP / RPM	1/4 - 1100	1/4 - 1100	1/3 - 1000
Motor - Amps	1.2	1.2	1.5
Fan Diameter / CFM	20 / 3800	20 / 3800	20 / 4000
Refrigerant Charge - Oz.	126.4	264	236.8
Net Weight lbs.	460	570	580
Shipping weight lbs.	470	580	590

DIMENSIONS

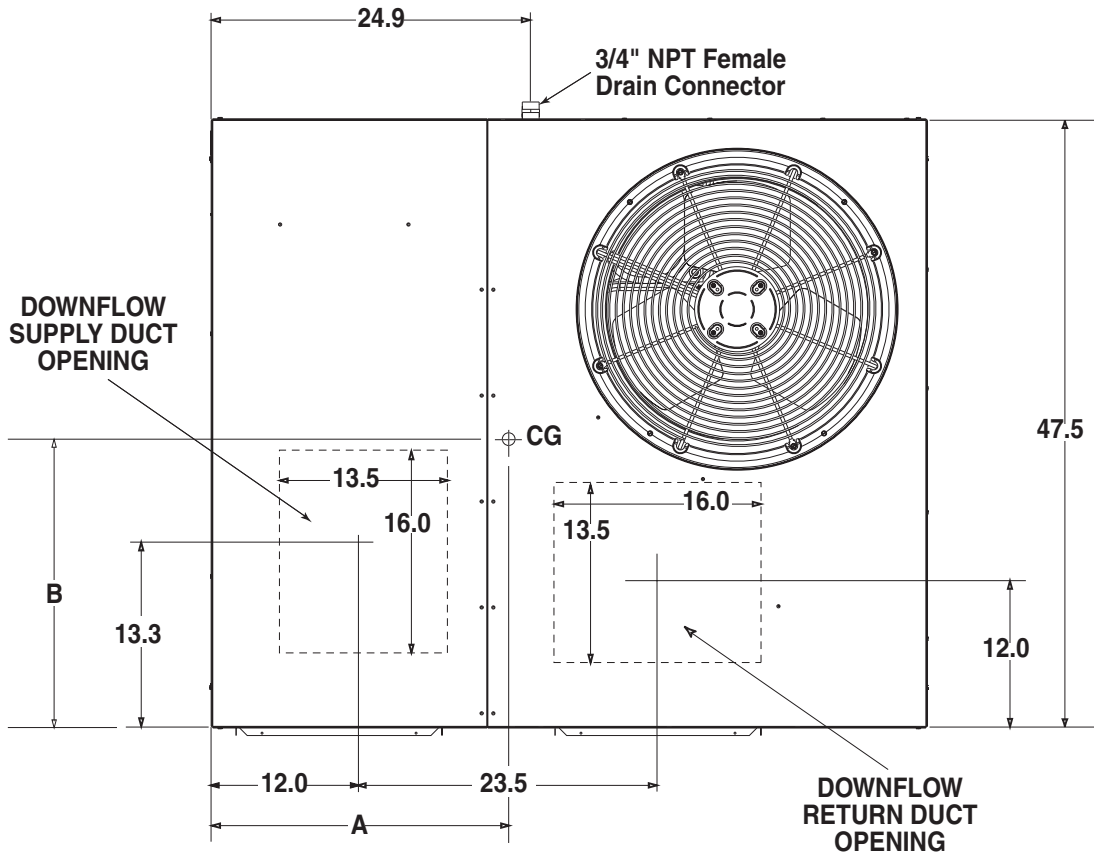

Top View

Model Number Q4SE	Unit Weight	Center of Gravity		Height (in inches)	
		A	B	C	
				with base rails	without base rails
-X36	460	28.0	25.5	39.0	35.3
-X48	570	29.5	26.0	43.0	39.3
-X60	580	29.5	26.0	43.0	39.3

DIMENSIONS continued

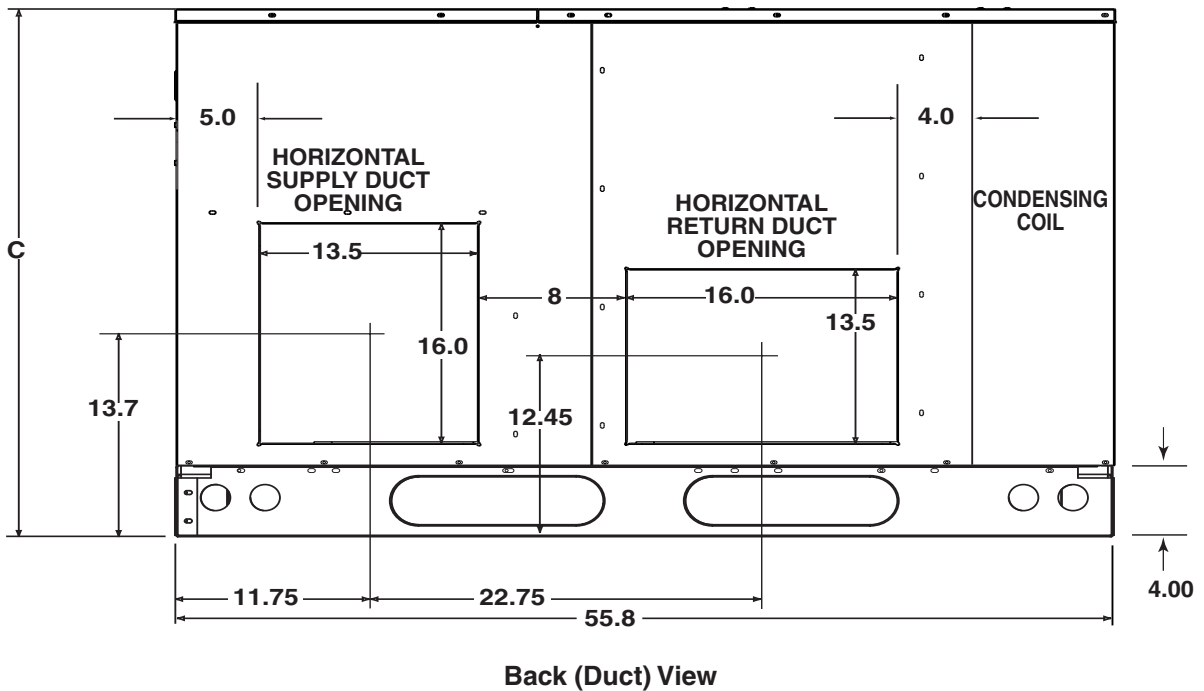
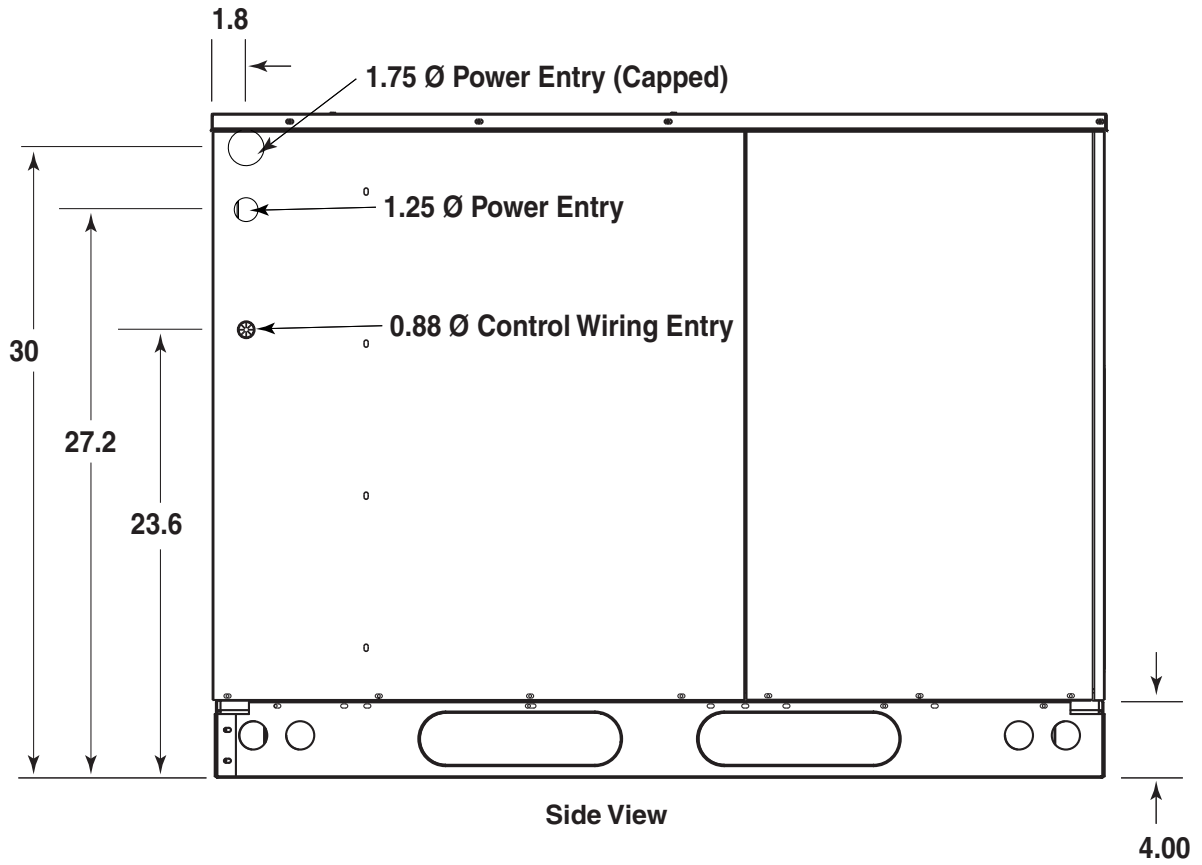

BLOWER PERFORMANCE

Basic Air-Flow Settings

1/2 HP Motor						3/4 HP Motor						
CFM	Switch				Nominal 3.0	CFM	Switch				Nominal	
	1	2	3	4			4.0	5.0				
1080	0	0	0	1	3 T O N	1395	0	0	0	1	4 T O N	5 T O N
1200	0	0	0	0		1485	1	0	0	1		
1215	1	0	0	1		1550	0	0	0	0		
1260	0	1	0	1		1620	0	1	0	1		
1320	0	0	1	0		1650	1	0	0	0		
1350	1	0	0	0		1705	0	0	1	0		
1395	1	1	0	1		1710	1	1	0	1		
1400	0	1	0	0		1800	0	1	0	0		
1485	1	0	1	0		1815	1	0	1	0		
1540	0	1	1	0		1900	1	1	0	0		
1550	1	1	0	0	1980	0	1	1	0			
1705	1	1	1	0	2090	1	1	1	0			

Note: 1=ON, 0=OFF

Air Flow Selection for Variable Speed Motors

Nominal KW	CFM	Switch Number							
		1	2	3	4	5	6	7	8
0-5	500					0	0		
6-10	700					1	0		
11-15	900					0	1		
16-20	1100					1	1		

Note: 1=ON, 0=OFF

Minimum Electric Heat Airflow

Delay Description	Switch Number							
	1	2	3	4	5	6	7	8
Delay A							0	0
Delay B							0	1
No Delay							1	0
De-Hum.							1	1

Note: 1=ON, 0=OFF

Delay Settings

HEATER APPLICATION MATRIX

Model Number	H3HK-005H-01	H3HK-008H-01	H3HK-010H-01	H3HK-015H-01	H3HK-020H-01	H3HK-015H-21	H3HK-020H-21
	917166	917167	917168	917169	917170	917172	917173
Q4SEX36K	X	X	X(2)	X(2)	NA	X	NA
Q4SEX48K	X(2)	X(2)	X(2)	X(3)	X(3)	X(1)	X(1)
Q4SEX60K	X(2)	X(2)	X(2)	X(3)	X(3)	X(1)	X(1)

NA = Not Applicable.

() = Number of internal circuit breaker kits required.

IDENTIFICATION CODE

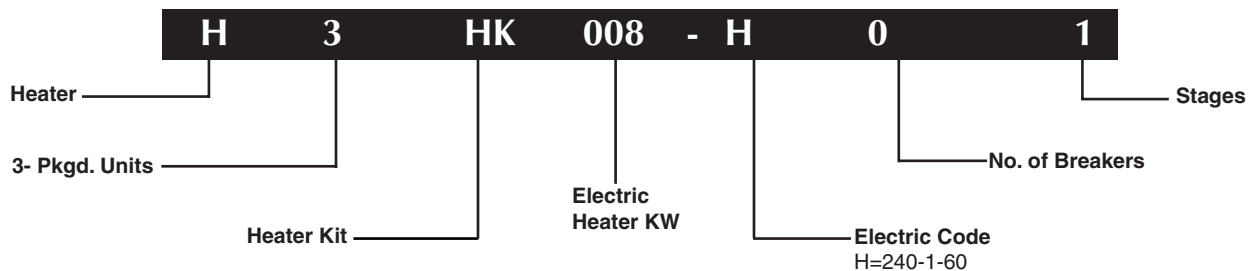

ACCESSORIES

Description	Part Number
Roof Curb (8")	547830
Roof Curb (14")	547831
Roof Curb (18")	547850
Roof Curb (24")	547851
Supply/return transition, 16"	547834
Supply/return transition, 18"	547835
Concentric diffuser, flush, 16"	547836
Concentric diffuser, flush, 18"	547837
Concentric diffuser, step down 16"	547838
Concentric diffuser, step down 18"	547839
HOOD TYPE HAIL GUARD 34" X 76" Q4SD/EX24, X30, X36	547846
HOOD TYPE HAIL GUARD 38" X 76" Q4SD/EX42, X48, X60	547847
CO2 sensors (special order)	547848
DUCT SMOKE DETECTOR PHOTO ELEC	547892
MULTI SIGNAL CONTROL	547893
SAMPLING TUBE ST3	547894
SAMPLING TUBE ST5	547895
Filter Rack, All Downflow Applications (not required with economizer)	547885
Filter Kit (not required with economizer) Q4SD/EX24, X36	547888
Filter Kit (not required with economizer) Q4SD/EX48, X60	547889
Universal Hard Start Kit	912933
Low Pressure Switch Kit	913551
High Pressure Switch Kit	913550
Low Ambient Kit	913549A
Outdoor Thermostat Kit	913852



Before purchasing this appliance, read important energy cost and efficiency information available from your retailer. Specifications and illustrations subject to change without notice and without incurring obligations.

Maytag is a registered trademark of the Maytag Corporation and is used under license to NORDYNE Inc.

398C-1206 (Replaces 398C-1006)

Printed in U.S.A. (12/06)