

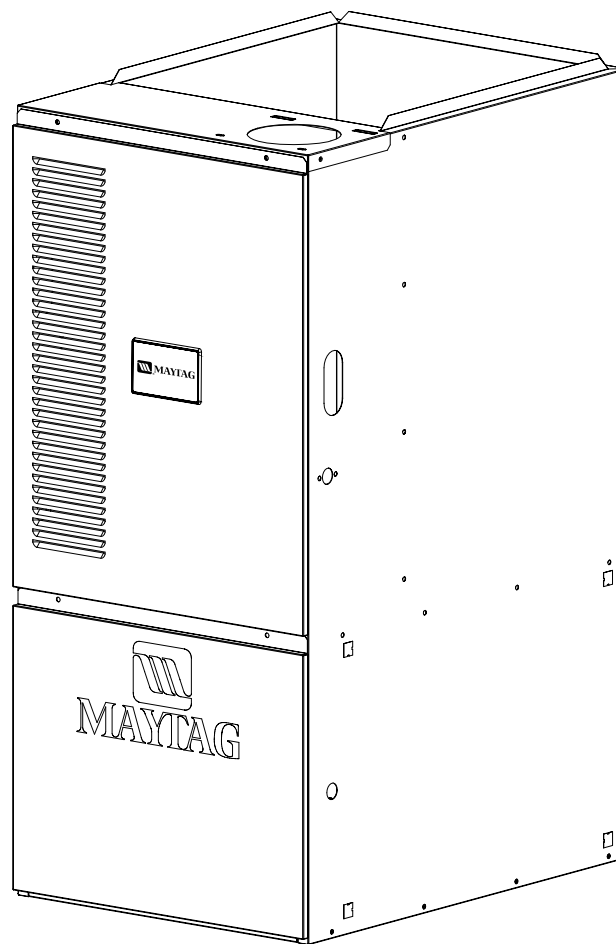

TECHNICAL SPECIFICATIONS

Model PGF1TA 2 Stage Series Upflow/Horizontal



M1010 Product Line

High Efficiency / 80+ Upflow/Horizontal 2 Stage Gas Furnace with Variable Speed Blower

- **10 YEAR
WARRANTY**
- **WORRY-FREE
PERFORMANCE**
- **5 YEAR
DEPENDABILITY
PROMISE**



The high efficiency 2-Stage gas furnace may be installed free standing in a utility room, basement, or enclosed in an alcove or closet. The extended flush jacket provides a pleasing “appliance appearance.” Design certified by the Canadian Standards Association (CSA) International. The product is truly designed with the contractor and the consumer in mind.

Features and Benefits

Best warranty in the business —

- A 20 year warranty on the heat exchanger
- 10 Year Parts and Labor Warranty and 5 Year Dependability Promise.
- **100% fired and tested** — All units and each component (both mechanical and electrical) are tested on the manufacturing line.
- **Best packaging in the industry** — Unique design assures product will arrive to the homeowner dent free.
- **Clean, quiet and efficient operation** — Due to the unique design of in-shot burners, location of inducer and use of insulation. Operation at low fire uses less fuel than single capacity furnaces.
- **Fixed 30 second blower delay** at burner start-up assures a warm duct temperature at furnace start-up. Adjustable blower off settings (60, 120, 160 and 180 seconds).
- **Fixed 30-second post purge** increases life of heat exchanger.
- **SmartStart™ Control Board** — Provides extended life to ignitors in furnaces using hot surface ignition technology. Programmed to learn the heat-up characteristics of the ignitor, then adapt the ignition time to the characteristics of the furnace so the ignitor is energized appropriately.
- **Dependable, hot surface igniter** — Innovative application of an appliance type ignitor with a 20-year history of reliability, assures no call-backs because of handling.
- **Color coded wire harness** — Designed to fit the components, all with quick-connect fittings for ease of service and replacement.
- **Tubular primary heat exchanger** — Heavy gauge aluminized steel heat exchanger assures a long life.
- **Fixed cooling cycle blower-off delay (TDR)** increases cooling performance when matched with a Maytag coil.
- **Approved for category I and III venting systems** – May be common, dedicated, or horizontal vented for maximum flexibility in installation.
- **Fully insulated blower cabinet** for quiet operation.
- **Variable speed blower** — Maximizes air conditioner and heat pump efficiencies. On selected units, SEER ratings up to 14 and HSPF ratings up to 8.5 are ARI listed.
- **LP convertible** — Simple burner orifice and regulator spring change for ease of convertibility.
- **Diagnostic light flashes identify limit failure, pressure switch failure and improper ground and polarization** — for easy troubleshooting.
- **Incorporates integrated control board** with connections for electronic air cleaner, humidifier and twinning.
- **Two piece door design** enhances furnace appearance and uses screw fasteners for great fit and accessibility.
- **3 amp fuse** protection against low voltage shorts; protects transformer and control board.
- **Low voltage terminal board** for easy field wiring.

High Efficiency Upflow/Horizontal 80+ Two Stage Gas Furnace

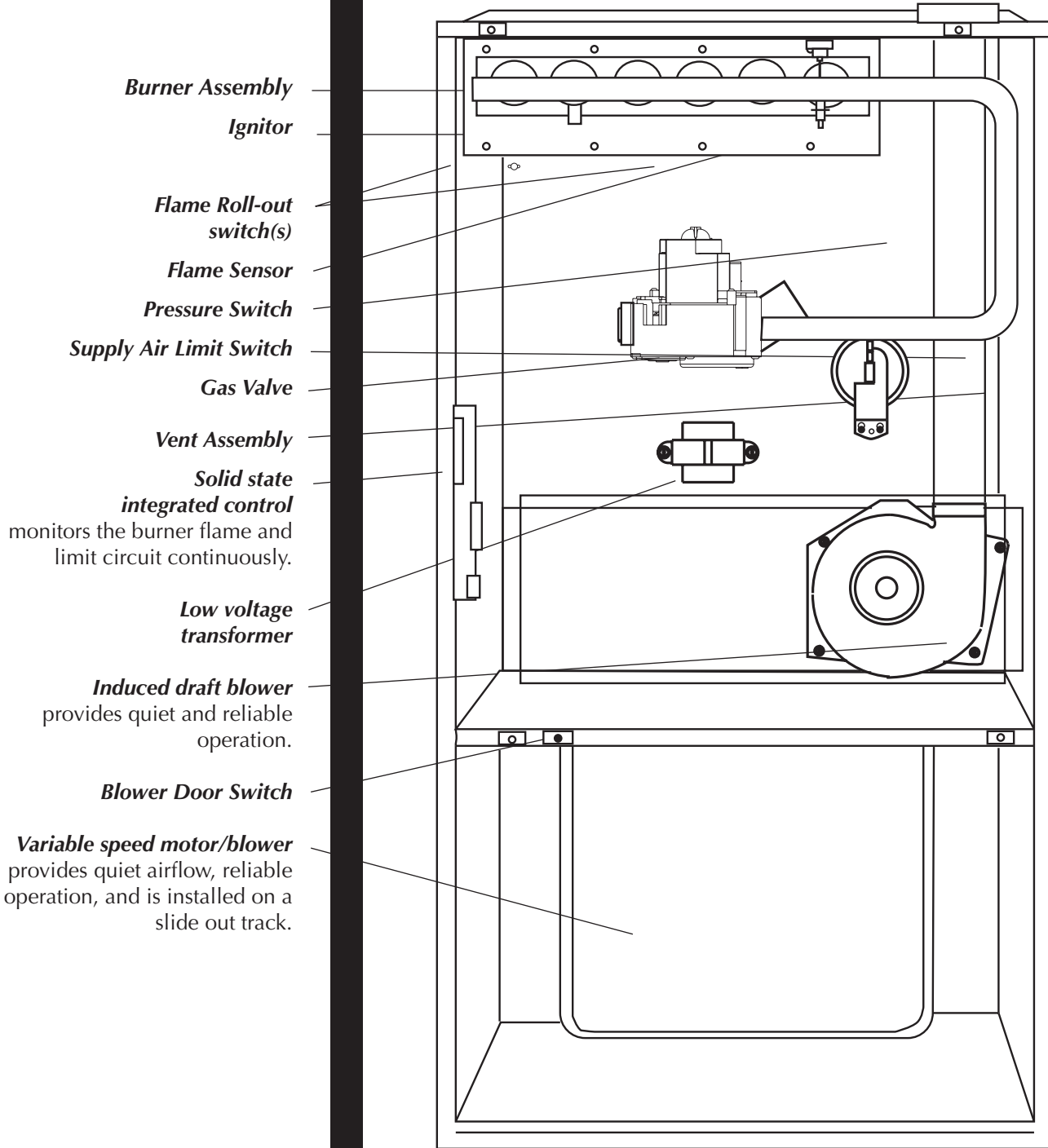

DIMENSIONS

Upflow/Horizontal Furnace

UPFLOW/HORIZONTAL FURNACE MODELS FURNACE DIMENSIONS AND SHIPPING WEIGHTS								
Model No	High Fire Input	Low Fire Input	Dimensions				Flue Outlet	Shipping Weight
			A	B	C	D		
	Btuh	Btuh	In.	In.	In.	In.	In.	Lbs
*TA 072C-VB	72,000	50,000	19 3/4	18 1/4	3 3/4	17 1/4	4	152
*TA 096C-VB	96,000	67,000	19 3/4	18 1/4	3 3/4	17 1/4	4	174
*TA 120C-VC	120,000	84,000	22 1/2	21	3 3/4	20	4	182

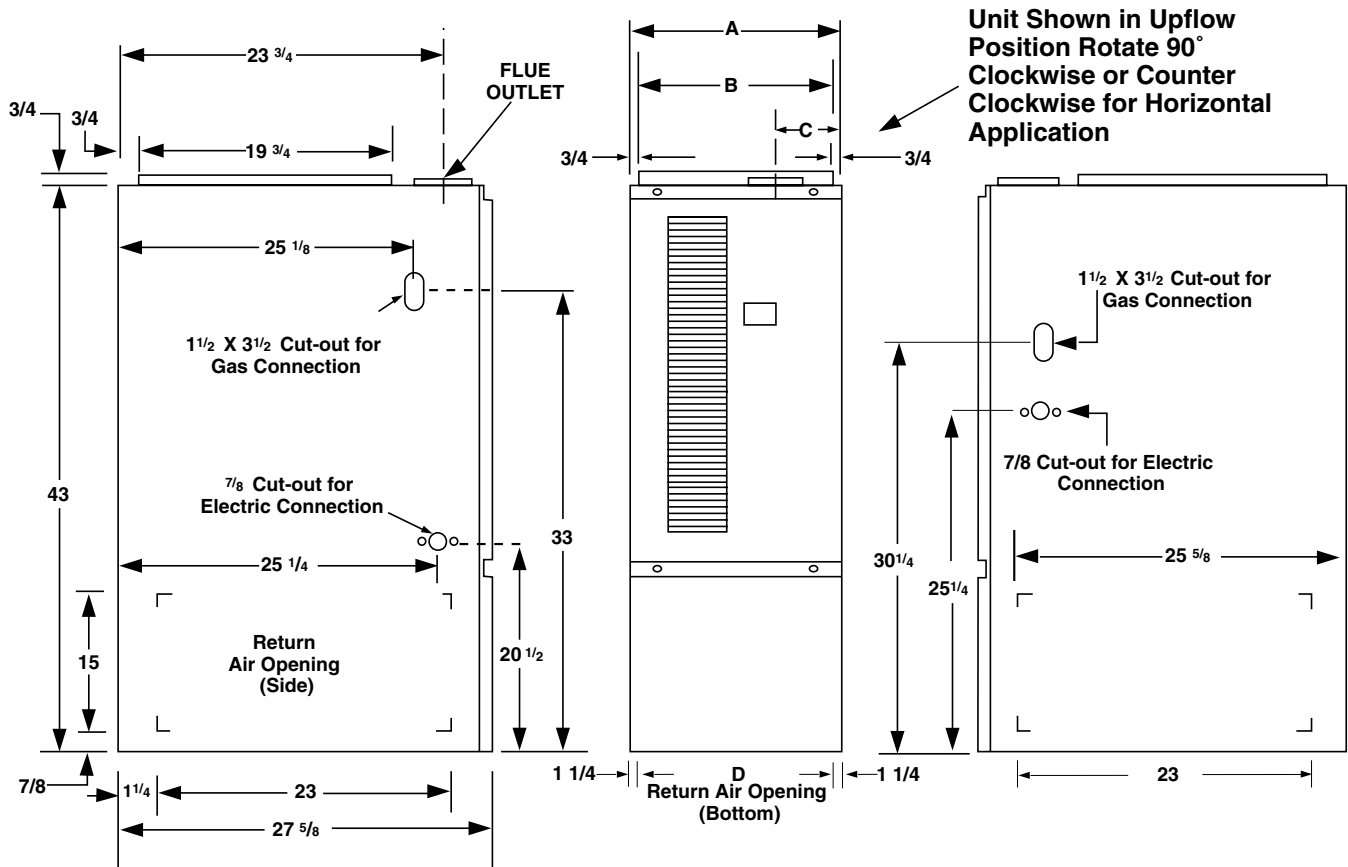

STANDARD EQUIPMENT

Direct vent; draft inducer; pressure switch; redundant main gas control; hot-surface ignition; timed ON/OFF blower controls (TDR); 40VA transformer for air conditioner application; limit controls; direct drive motor; all models can be converted to use L.P. (propane) gas. Factory approved kits only must be used and are available as an optional accessory from your Maytag distributor.

SPECIFICATIONS

MODEL NUMBER PGF1TA	072()VB	096()VB	120()VC
High Fire Rated Input(Btu/h) (a)	72,000	96,000	120,000
High Fire Heating Capacity(Btu/h)	58,000	77,000	96,000
Low Fire Rated Input(Btu/h) (a)	50,000	67,000	84,000
Low Fire Heating Capacity(Btu/h)	40,000	54,000	67,000
AFUE	80+	80+	80+
Maximum Heating Ext. St. Press.(in WC)	1.0	1.0	1.0
Blower Wheel D x W	11 x 10	11 x 10	11 x 10
Motor H.P. -Type	3/4 - Variable	3/4 - Variable	3/4 - Variable
Motor FLA	9.6	9.6	9.6
High Fire Temperature Rise Range(F)	35 - 75	40 - 70	40 - 70
Low Fire Temperature Rise Range(F)	40 - 70	45 - 75	35 - 65

IDENTIFICATION CODE

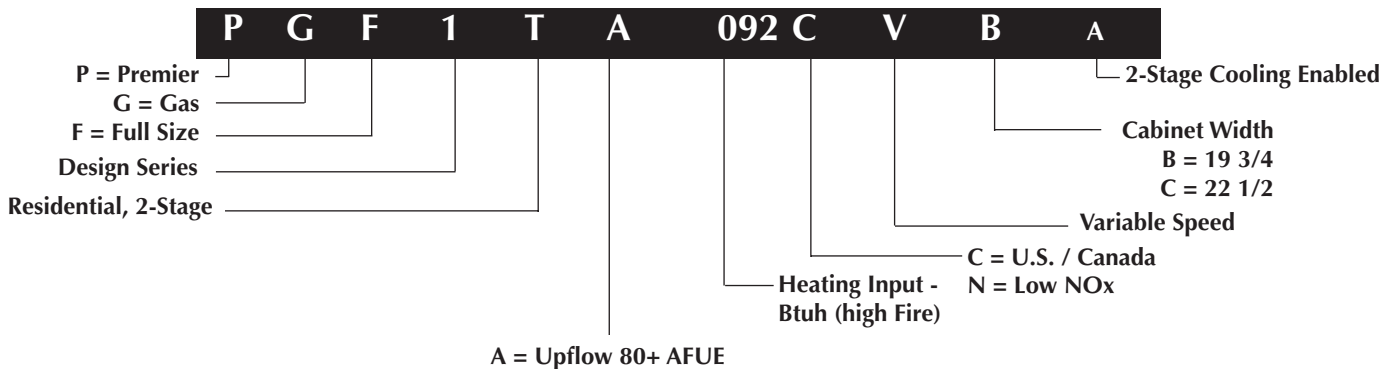

VENTING

All models, with the exception of the reduced NOx models, are approved for vertical and horizontal venting applications. All models may be common vented with a gas water heater. Type B gas vent materials may be used when connected to a vertical vent system. The installation must be in accordance with the venting instructions supplied with the furnace.

Furnace Model Number PGF1TA	Pipe Size	Reducer Needed	Maximum # Elbows	Max. Feet Vent Pipe
072()VB	3"	4" to 3"	4	35
096()VB	3"	4" to 3"	4	35
120()VC	3"	4" to 3"	4	35

ACCESSORIES

Kit	Order Number
U.S. LP Conversion Kit (0 to 10,000 ft.)	904404
Canadian LP Gas Conversion Kit (0 to 4,500 ft.)	904405
Fossil Fuel Kit	914762
Side Return Filter Kit	541036
Bottom Return Filter (20/Box)	B Cabinet 903089 C Cabinet 903090
Internal Side Return Filter Wire	903152
Downflow "B" Combustion Floor Base	902677
Downflow "C" Combustion Floor Base	904108

CAPACITIES — Furnace Airflow Data

Cooling/Heat Pump Airflow Settings

CFM	SWITCH NUMBER							Nominal A/C and HP Capacity		
	LOW	HIGH	1	2	3	4	5		6	7
500	720	0	0	0	1					
550	800	0	0	0	0					
610	880	0	0	1	0					2 TON
650	945	1	0	0	1					2.5 TON
720	1050	1	0	0	0					3 TON
800	1155	1	0	1	0					3.5 TON
900	1305	0	1	0	1					4 TON
1000	1450	0	1	0	0					5 TON
1060	1530	1	1	0	1					4 TON
1100	1595	0	1	1	0					5 TON
1170	1700	1	1	0	0					4 TON
1290	1870	1	1	1	0					5 TON

NOTE: 0 = OFF 1 = ON

Heating Airflow Settings

Nominal Airflow Rates (CFM) and Temperature Rises (Degree F)														
Switches			*TA 072-VB Models				*TA 096-VB Models				*TA 120-VC(B) Models			
			Low Fire Input		High Fire Input		Low Fire Input		High Fire Input		Low Fire Input		High Fire Input	
5	6	7	50,000		72,000		67,000		96,000		84,000		120,000	
0	0	#	660	54	1090	50	660	73	1090	63	660	92	1090	84
1	0	#	750	48	1240	44	750	64	1240	58	750	80	1240	74
0	1	#	1220	30	1680	33	1220	40	1680	41	1220	50	1680	55
1	1	#	1300	28	1880	29	1300	37	1880	36	1300	47	1880	49

Switch not used - Can be 0 or 1.

Notes:

1. Recommended temperature rises are highlighted in bold.
2. Airflow rates of 1800 CFM or more require two return air connections. Data is for operation with filter(s).
3. Temperature rises in the table are approximate. Actual temperature rises may vary.
4. Temperature rises that are shaded grey are for reference only. These conditions are not recommended.
5. For single stage cooling, the indoor blower will operate at the CFM listed in the high column.

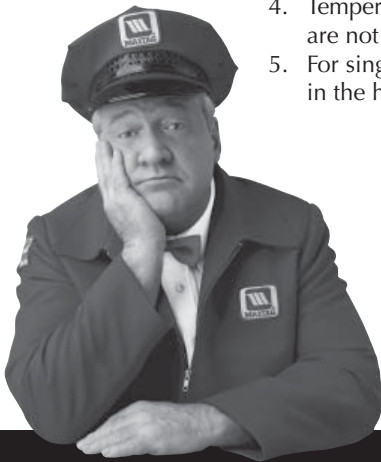

Before purchasing this appliance, read important energy cost and efficiency information available from your retailer. Specifications and illustrations subject to change without notice and without incurring obligations.

Maytag is a registered trademark of the Maytag Corporation and is used under license to NORDYNE Inc.

470B-0606 (Replaces 470B-0305)

Printed in U.S.A. (06/06)