

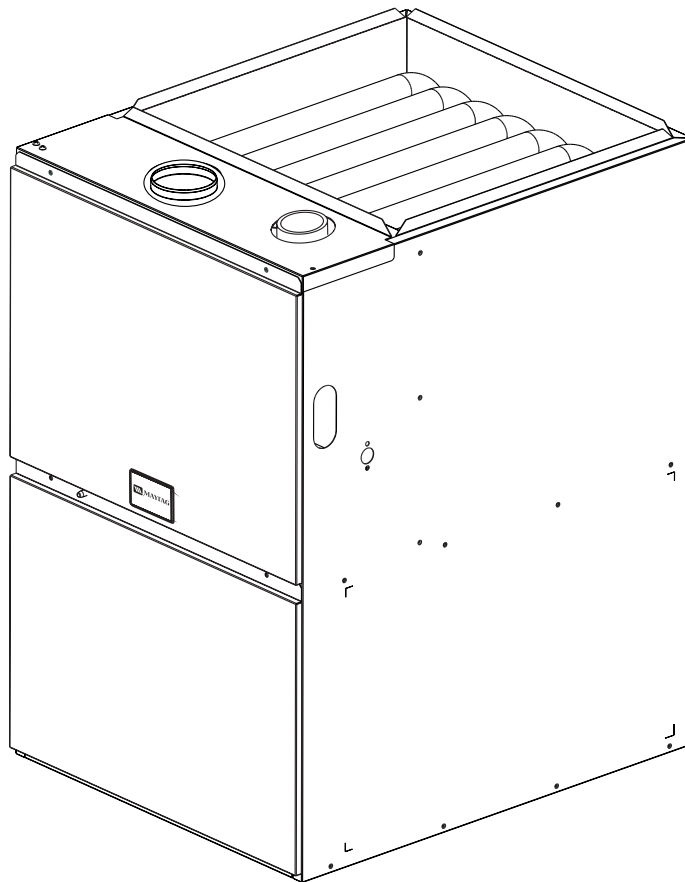

## TECHNICAL SPECIFICATIONS

*Model MGC1RC Series*



M1000 Product Line

**Upflow/Horizontal Gas Furnace  
92+ AFUE**



- **10 YEAR WARRANTY**
- **WORRY-FREE PERFORMANCE**



The compact high efficiency upflow/horizontal gas furnace may be installed free standing in a utility room, basement, or enclosed in an alcove or closet. The extended flush jacket provides a pleasing "appliance appearance." The product is truly designed with the contractor and the consumer in mind.

### Features and Benefits

#### Best warranty in the business —

- A lifetime warranty on the heat exchanger
- 10 Year Limited Parts
- **100% fired and tested** — All units and each component (both mechanical and electrical) are tested on the manufacturing line.
- **Best packaging in the industry** — Unique design assures product will arrive to the homeowner dent free.
- **Clean and quiet operation** — Due to the unique design of in-shot burners, location of inducer and use of insulation.
- **Fixed 30 second blower delay** at burner start-up assures a warm duct temperature at furnace start-up. Adjustable blower off settings (60, 90, 120 and 180 seconds).
- **Fixed 30-second post purge** increases life of heat exchanger.
- **Dependable, hot surface ignitor** — Innovative application of an appliance type ignitor with a 20-year history of reliability, assures no call-backs because of handling.
- **Color coded wire harness** — Designed to fit the components, all with quick-connect fittings for ease of service and replacement.
- **Approved for direct vent furnace, category IV venting system** — May be vertically or horizontally vented using either a one-pipe or two-pipe system for maximum flexibility in installation.
- **Tubular primary heat exchanger** — Heavy gauge aluminized steel heat exchanger assures a long life.
- **Stainless steel secondary heat exchanger** — Assures a long life.
- **SmartStart™ Control Board** — Provides extended life to ignitors programmed to learn the heat-up characteristics of the ignitor so the ignition timing is energized appropriately.
- **Fixed cooling cycle blower-off delay (TDR)** increases cooling performance when matched with a Maytag coil.
- **Furnace is easy to handle** — short and lightweight.
- **Fully insulated blower cabinet** for quiet operation.
- **Multi-speed direct drive blower** — Designed to give a wide range of cooling capacities. 40VA transformer included.
- **LP convertible** — Simple burner orifice and regulator spring change for ease of convertibility.
- **Diagnostic lights flash to identify limit failure, pressure switch failure, improper ground and polarization, and low flame signal** — for easy troubleshooting.
- **Two piece door design** enhances furnace appearance and uses screw fasteners for easier accessibility.
- **3 amp fuse** protection against low voltage shorts; protects transformer and control board.
- **Low voltage terminal board** for easy field wiring.
- **Factory installed drain system** for reliable performance.

**Counterflow heat exchanger orientation and aluminized steel tubular design** means improved efficiency and durability.

**Front door screw fasteners** ensure tight fit.

**Aluminized steel in-shot burners, hot surface ignitor and redundant gas valve** provide safe, reliable ignition and efficient combustion.

**Solid state integrated control** monitors the burner flame and limit circuit continuously. Blower timing has adjustable OFF settings. Proves humidifier and electronic air cleaner connections.

**Induced draft blower** provides quiet and reliable operation.

**Vent switch** protects against blocked flue.

**Factory Installed drain** for reliable performance.

**Easy Access to Pressure Switch.** Assures proper operation of induced draft system.

**Multi-speed PSC motor/blower** provides quiet airflow, reliable operation and is installed on a slide out track.

**Fully insulated blower compartment.**

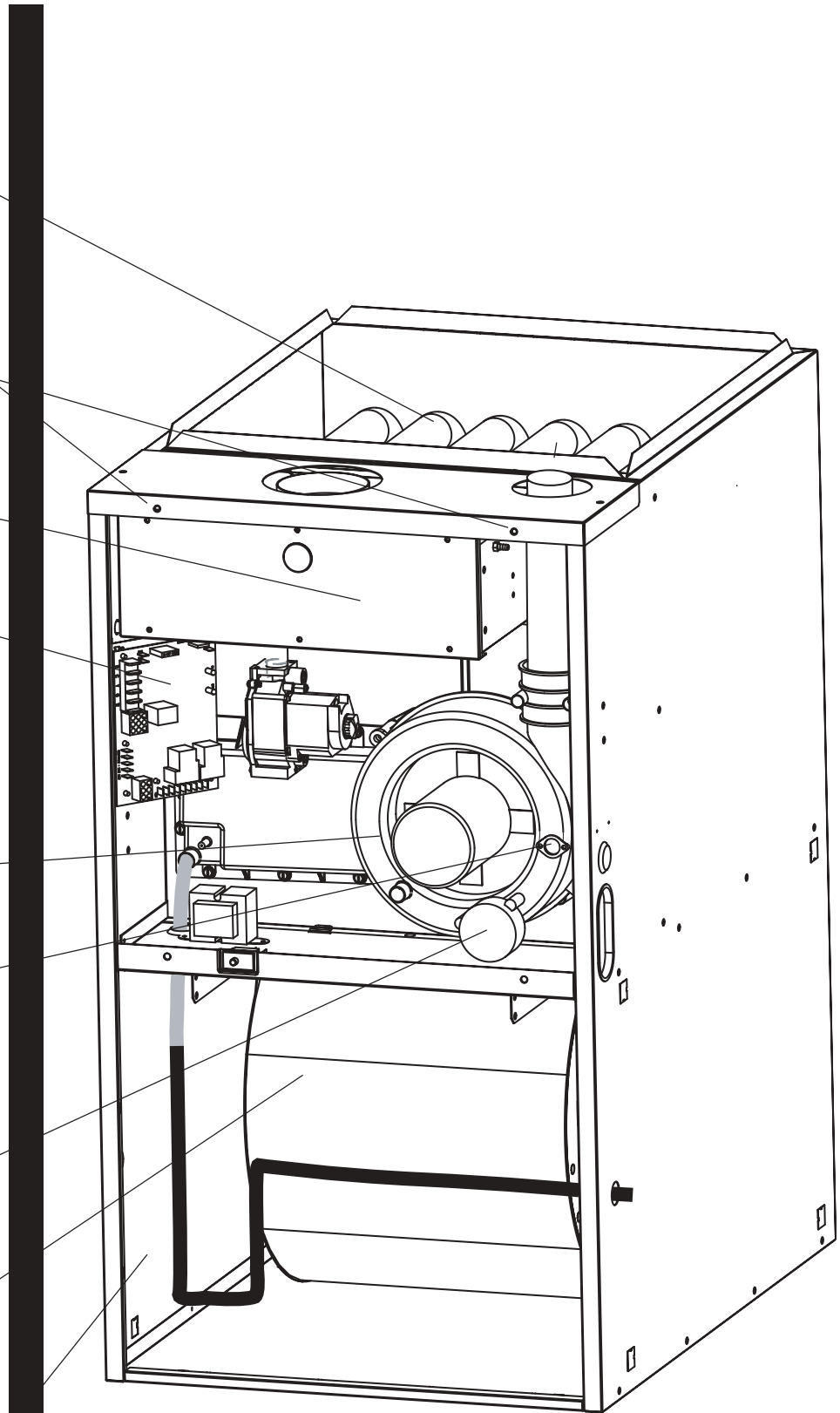

# DIMENSIONS

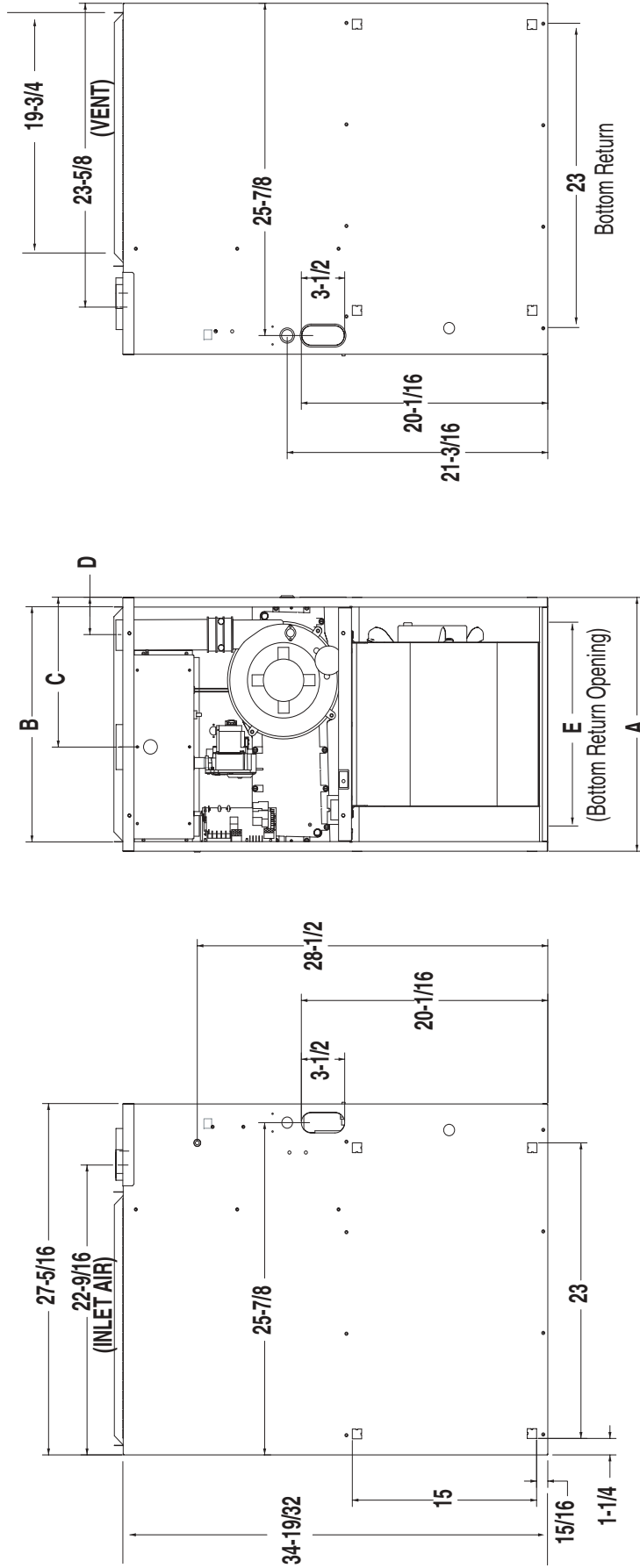

MODEL NUMBER	Dimensions				Shipping Weights (lbs)
	A (in.)	B (in.)	C (in.)	D (in.)	
MGC1RC					
040D-08A	14 1/4	12 13/16	8 5/8	2 11/16	88
060D-12A	14 1/4	12 13/16	8 5/8	2 11/16	92
080D-12B	19 3/4	18 5/16	9 11/16	2 15/16	98
080D-16B	19 3/4	18 5/16	9 11/16	2 15/16	102
100D-16B	19 3/4	18 5/16	9 11/16	2 15/16	130
120D-16C	22 1/2	21 1/16	13 1/8	2 13/16	135
120D-20C	22 1/2	21 1/16	13 1/8	2 13/16	140

# STANDARD EQUIPMENT

Draft inducer; pressure switch; redundant main gas control; hot-surface ignition; timed ON/OFF blower controls (TDR); 40VA transformer for air conditioner application; limit controls; solid base plate with knock-out for easy removal; direct drive motor; all models can be converted to use L.P. (propane) gas. Factory approved kits *only* must be used and are available as an optional accessory from your distributor.

# SPECIFICATIONS

MGC1RC MODEL NUMBERS	040D08A	060D12A	080D12B	080D16B	100D16B	120D16C	120D20C
Input-Btuh (a)	38,000	60,000	80,000	80,000	100,000	120,000	120,000
Heating Capacity - Btuh	35,000	56,000	76,000	76,000	93,000	112,000	112,000
AFUE	92.1	92.1	92.1	92.1	92.1	92.1	92.1
Max. Htg. Ext. St. Press. In W.C.	.5	.5	.5	.5	.5	.5	.5
Blower Wheel D x W	10 x 6	10 x 6	10 x 8	10 x 10	10 x 10	10 x 10	11 x 10
Motor H.P. -Speed -Type	1/5-2-PSC	1/3-3-PSC	1/3-3-PSC	1/2-4-PSC	1/2-4-PSC	1/2-4-PSC	3/4-4-PSC
Motor FLA	4.0	6.0	6.0	7.9	7.9	7.9	11.1
Temperature Rise Range - °F	30 - 60	35 - 65	35 - 65	35 - 65	40 - 70	50 - 80	50 - 80

Note: All models are 115V, 60 Hz. Gas Connections are 1/2" N.P.T. AFUE = Annual Fuel Utilization Efficiency

(a) Ratings to 2,000 ft. Over 2,000 ft. reduce 4% for each 1,000 ft. above sea level.

# VENTING

All models are approved for vertical non direct (1 pipe) and direct (2 pipe) venting applications. See Vent Table below for specified sizes and allowable lengths.

MODELS	SINGLE PIPE LENGTH (FT.) with 1 long radius elbow**		DIRECT VENT, DUEL PIPE LENGTH (ft.) WITH 1 long radius elbow on each pipe**	
	OUTLET	OUTLET	INLET/OUTLET	INLET/OUTLET
	2"	3"	2"	3"
MGC1RC040	60	90	30	90
MGC1RC060	50	70	30	50
MGC1RC080	30	90	15	90
MGC1RC100	50	70	20	60
MGC1RC120	N/A	40	N/A	40

### \*\*NOTES

1. Subtract 2.5 ft. for each additional 2" **long** radius elbow, 5 ft. for each additional 2" **short** radius elbow, 3.5 feet for each additional 3" **long** radius elbow, and 7 feet for each additional 3" **short** radius elbow.
2. Two 45 degree elbows are equivalent to one 90 degree elbow.
3. Do not include termination elbows in calculation of vent length
4. This table is applicable for elevations from sea level to 2000 ft. For higher elevations decrease vent pipe lengths by 8% per 1000 ft. of altitude.
5. Only the above pipe materials are approved for use with these condensing furnaces.

Kit Description	2" PVC	3" PVC
Horizontal Venting Exterior Wall Vent Kit	902373	902375
Concentric Vent Kit	903578	
Neutralizer Kit (all models)	902377	

# BLOWER PERFORMANCE

MODEL NUMBER MGC1RC	HEATING INPUT	MOTOR SPEED	MOTOR HP	EXTERNAL STATIC PRESSURE (INCHES OF WATER COLUMN)															
				0.1		0.2		0.3		0.4		0.5		0.6		0.7		0.8	
				CFM	Rise	CFM	Rise	CFM	Rise	CFM	Rise	CFM	Rise	CFM	Rise	CFM	Rise	CFM	Rise
040D-08A	36,000	HIGH** LOW*	1/5	945 720	36 47	920 700	37 49	885 665	39 51	850 630	40 54	815 600	42 57	785 560	43 60	730 510	47 -	675 460	50 -
060D-12A	60,000	HIGH* MEDIUM** LOW	1/3	1300 1110 715	40 46 -	1260 1075 705	41 47 -	1210 1050 690	42 49 -	1170 1020 660	44 50 -	1115 985 635	45 52 -	1060 940 605	48 54 -	1000 885 565	47 58 -	850 675 520	55 62 -
080D-12B	80,000	HIGH* MEDIUM** LOW	1/3	1495 1225 760	45 55 -	1450 1200 735	47 57 -	1390 1155 710	49 59 -	1310 1100 675	52 62 -	1245 1050 630	55 65 -	1160 965 585	58 71 -	1030 885 525	66 -	805 450	71 64 -
080D-16B	80,000	HIGH* MED-HIGH** MED-LOW** LOW	1/2	1955 1665 1415 1200	35 41 48 57	1890 1630 1385 1185	36 42 50 58	1825 1580 1360 1165	37 43 50 59	1755 1535 1325 1140	39 44 51 60	1680 1480 1285 1095	41 46 53 62	1605 1420 1235 1045	42 48 55 65	1510 1345 1170 995	45 51 58 -	1400 1250 1085 930	49 55 63 -
100D-16B	100,000	HIGH* MED-HIGH** MED-LOW** LOW	1/2	1955 1665 1415 1200	43 51 60 -	1890 1630 1385 1185	45 52 61 -	1825 1580 1360 1165	47 54 62 -	1755 1535 1325 1140	49 55 64 -	1680 1480 1285 1095	51 58 66 -	1605 1420 1235 1045	53 60 70 -	1510 1345 1170 995	56 63 -	1400 1250 1085 930	61 68 -
120D-16C	120,000	HIGH* MED-HIGH** MED-LOW** LOW	1/2	1955 1670 1400 1190	52 61 -	1900 1635 1380 1185	53 62 -	1840 1580 1375 1165	55 64 -	1770 1545 1340 1150	57 66 -	1695 1490 1305 1120	60 68 -	1620 1425 1250 1060	63 70 -	1520 1360 1190 1010	67 -	1420 1265 1100 950	- -
120D-20C	120,000	HIGH* MED-HIGH** MED-LOW** LOW	3/4	2230 1840 1595 1365	45 55 64 -	2175 1830 1570 1345	47 55 65 -	2120 1810 1550 1335	48 56 66 -	2070 1780 1540 1315	49 57 66 -	2010 1755 1505 1300	51 58 68 -	1935 1710 1455 1275	53 59 70 -	1865 1665 1410 1210	55 61 -	1790 1570 1370 1160	57 65 -

- \* Factory Set Cooling Speed
- \*\* Factory Set Heating Speed
- Not Recommended

Notes:

1. Airflow rates of 1800 CFM or more require two return air connections. Data is for operation with filter(s).
2. Temperature rises in the table are approximate. Actual temperature rises may vary.
3. Temperature rises and airflows for external static pressures greater than 0.5 are for reference only. These conditions are not recommended.

# ACCESSORIES

Kit	Order Number
U.S. LP Conversion Kit (0 to 10,000 ft.)	904090
Canadian LP Gas Conversion Kit (0 to 4,500 ft.)	904091
Fossil Fuel Kit	914762
Side Return Filter Kit	541036
Bottom Return Filter (20/Box)	A Cabinet 903088 B Cabinet 903089 C Cabinet 903090
Internal Side Return Filter Wire	903152
Horizontal Positioned Furnace Vent Drain Kit 2"	904079
Horizontal Positioned Furnace Vent Drain Kit 3"	904080
Variable Speed Blower Kit for "B" & "C" Cabinets	904075

