

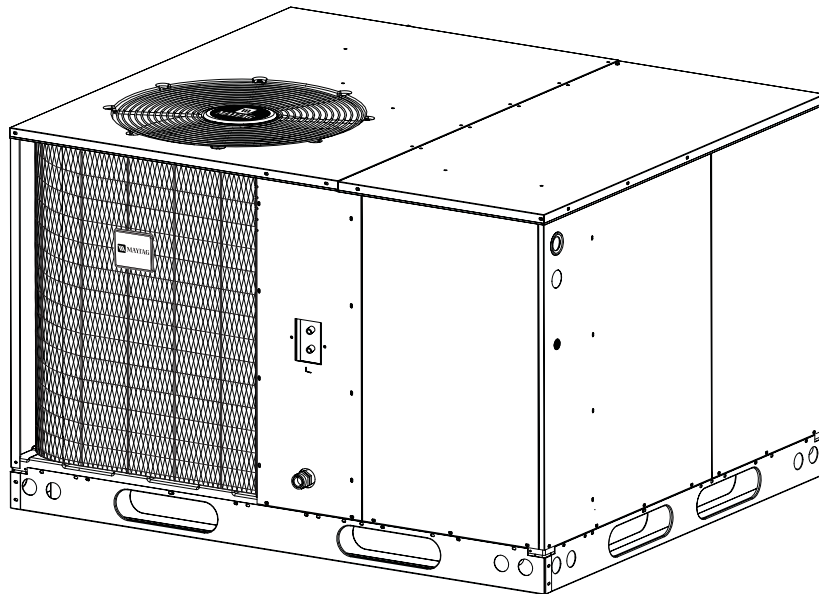

TECHNICAL SPECIFICATIONS

Model Q4SD Series



M1000 Product Line

**Single Packaged Heat Pump
13 SEER — 3 - 5 Ton Units**

- **10 YEAR
WARRANTY**
- **WORRY-FREE
PERFORMANCE**



The Q4 Series single packaged heat pumps are high efficiency self contained cooling and heating units that can be installed on a roof or on a slab. The convertible unit design makes installations simple in all applications. Units are ETL and ETLc listed.

Features and Benefits

- **Compact Footprint/Low Profile**
Easy to handle and transport.
- **Five Minute Restart Time Delay** – When the unit shuts down, a five minute delay keeps the unit from restarting, eliminating the highest cause for compressor failure.
- **Heavy-Gauge, Full Perimeter Base Rails**
Facilitates forklift handling and curb mounting.
- **Convertible Air Delivery**
Horizontal or downflow to accommodate rooftop or horizontal application.
- **Galvanized Steel Cabinet**
Polyurethane finish provides 950 hours salt spray protection.
- **Plastic Coated Coil Guard and Mesh Hail Guard**
Will never rust and protects the coil from being damaged by balls, lawnmowers, hail etc.
- **Externally Accessible Service Ports**
Quick access to refrigerant system without disrupting operation.
- **Access to Controls and Major Components**
Easy in and out service.
- **Corrosion-Resistant Drain Pan**
Quickly drains away evaporator condensate.
- **Service Access Panels**
Allows easy access to all major components and the compressor. Designed to make servicing easier for the Contractor.
- **Easy to Install**
Electric heat strip provides up to 20 KW of heat output.
- **Proven, Industry Standard Components**
Easier service and availability.
- **Quiet Operation and Low Vibration**
20" fan blade combined with custom venturi condenser fan.
- **Accessories**
Roof curbs, and more.
- **Time / Temperature Defrost** – A reliable, industry standard control offers various time settings to meet any type climate.
- **10 Year Residential Parts Warranty**
The best warranty in the business.

IDENTIFICATION CODE

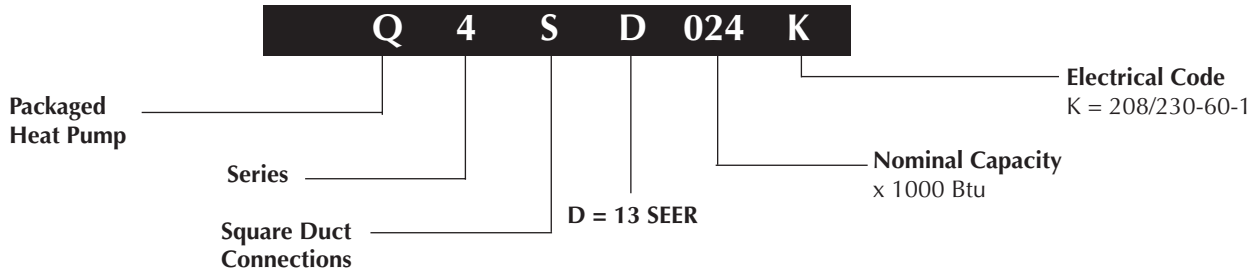

SPECIFICATIONS

Model Number	Q4SD		
	036	048	060
Performance			
Capacity - Heating BTUH	33,500	45,000	51,000
Efficiency - HSPF	7.7	7.7	7.7
Capacity - Cooling BTUH	34,800	46,000	55,500
Efficiency - SEER	13.00	13.00	13.00
EER (Btuh/watt)	11.0	11.0	11.0
Electric Rating - 60Hz (a)			
Phase	1	1	1
Operating Voltage Range	187-253	187-253	187-253
Min. Circuit Ampacity (a)	27.7	36.7	42.5
Field Wire Size - AWG (a)	10	8	6
Total Unit - Amps	23.2	30.8	35.5
Compressor Data			
Volts	208-230	208-230	208-230
Rated Load Amps	17.9	23.6	28.0
Lock Rotor Amps	88	137	169
Indoor Blower			
Type	Fixed Torque	Fixed Torque	Fixed Torque
Motor HP-RPM Range	1/2-1100	3/4-1400	3/4-1600
Motor - Amps	4.1	6.0	6.0
Outdoor Fan			
Motor - HP / RPM	1/4 - 1100	1/4 - 1100	1/3 - 1000
Motor - Amps	1.2	1.2	1.5
Fan Diameter / CFM	20 / 3800	20 / 3800	20 / 4000
Refrigerant Charge - Oz.	127	293	224
Net Weight lbs.	460	570	580
Shipping weight lbs.	470	580	590

BLOWER PERFORMANCE

Model Number Q4SD	Speed	External Static Pressure Drop-inches water column					
		0.1	0.2	0.3	0.4	0.5	0.6
036	* * Tap T1	1150	1050	1000	950	850	780
	* Tap T2	1230	1190	1120	1080	1000	950
	Tap T3	1400	1350	1200	1150	1080	1030
	Tap T4	1600	1500	1400	1300	1200	1050
	Tap T5	1700	1650	1600	1565	1530	1480
048	* Tap T1	1515	1450	1380	1350	1300	1250
	* * Tap T2	1580	1520	1460	1400	1360	1300
	Tap T3	1740	1690	1650	1600	1540	1500
	Tap T4	1960	1910	1840	1820	1780	1740
	Tap T5	2090	2050	2010	1975	1940	1900
060	* * Tap T1	1515	1450	1380	1350	1300	1250
	* Tap T2	1580	1520	1460	1400	1360	1300
	Tap T3	1740	1690	1650	1600	1540	1500
	Tap T4	1960	1910	1840	1820	1780	1740
	Tap T5	2090	2050	2010	1975	1940	1900

* Denotes factory set cooling and heat pump speed

** Denotes factory set electric heating speed

DIMENSIONS

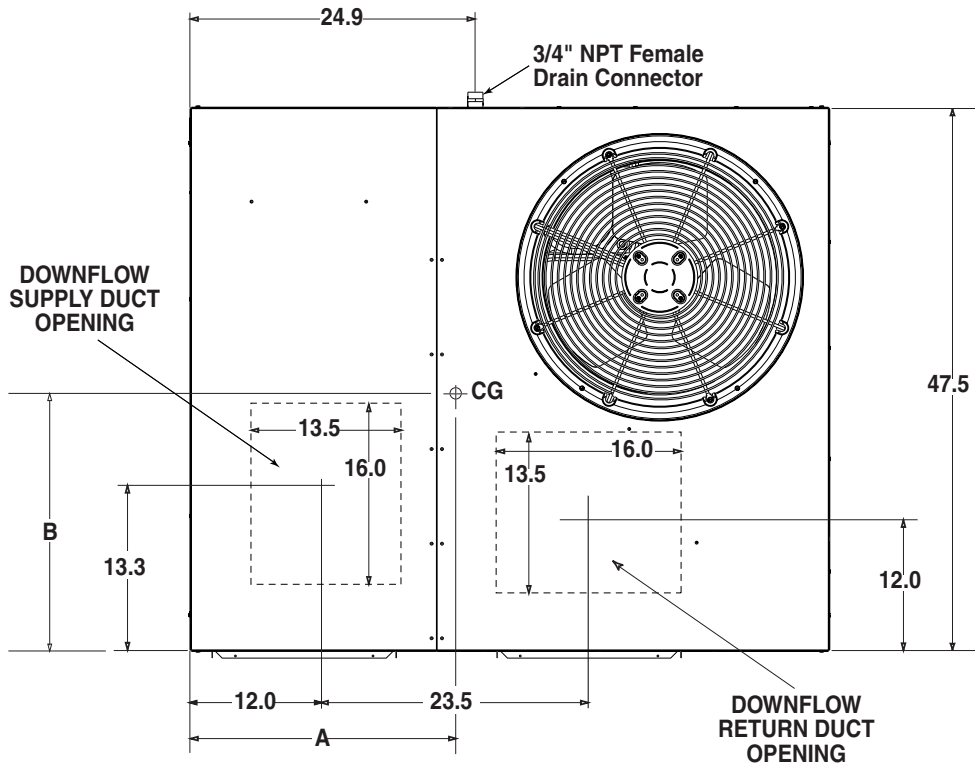

Top View

Model Number Q4SD	Unit Weight	Center of Gravity		Height (in inches)	
		A	B	C	
				with base rails	without base rails
036	460	28.0	25.5	35.0	35.3
048	570	29.5	26.0	43.0	39.3
060	580	29.5	26.0	43.0	39.3

DIMENSIONS continued

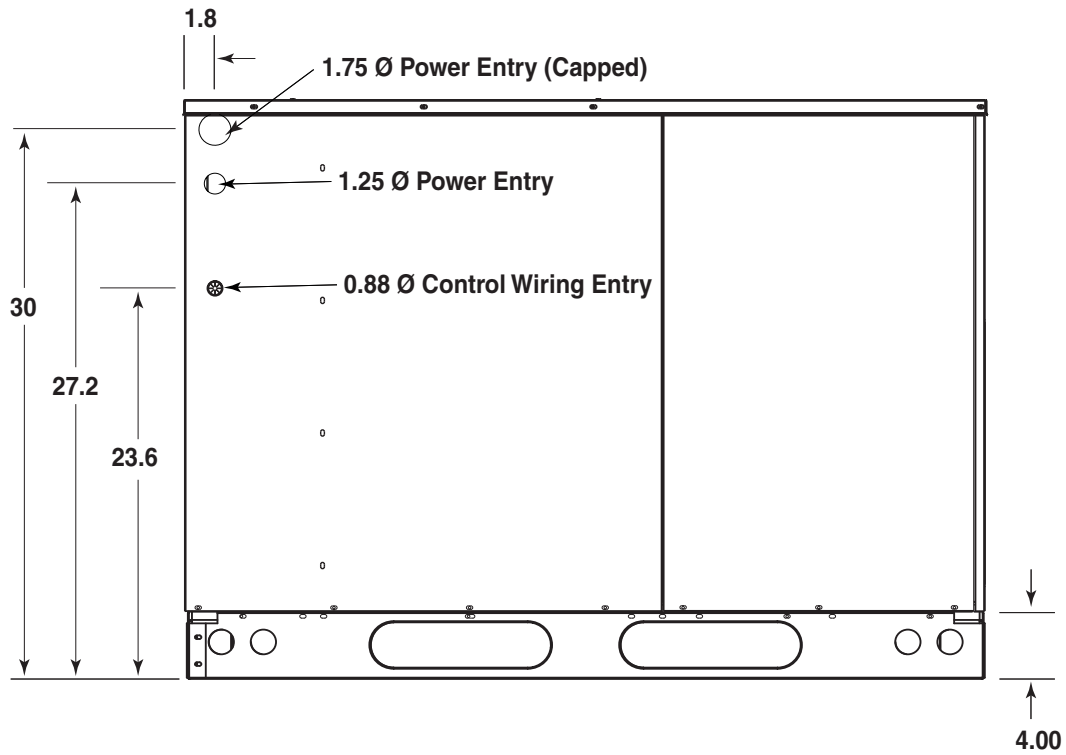

Side View

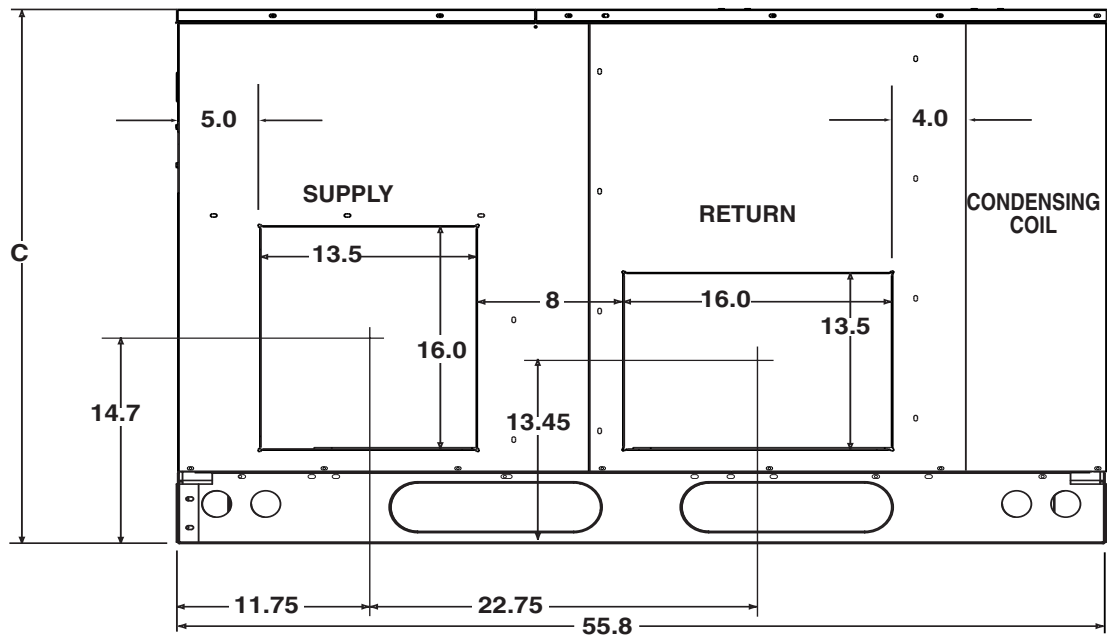

Back (Duct) View

ELECTRICAL DATA

Model Number	Heater Installed Nom. KW	Single Supply Circuit Option						Multiple Supply Circuit Option											
		Circuit A (Compressor & Fan)			Circuit B (Blower & Heater)			Circuit A (Compressor & Fan)				Circuit B (Blower & Heater)				Circuit C (Heater Only)			
		Minimum Circuit Amp.	Rec Wire Gauge (60° C Cu)	Rec Wire Gauge (90° C Cu)	Maximum Over-current Rating*	Minimum Circuit Amp.	Rec Wire Gauge (60° C Cu)	Rec Wire Gauge (90° C Cu)	Maximum Over-current Rating*	Minimum Circuit Amp.	Rec Wire Gauge (60° C Cu)	Rec Wire Gauge (75° C Cu)	Rec Wire Gauge (90° C Cu)	Maximum Over-current Rating*	Minimum Circuit Amp.	Rec Wire Gauge (60° C Cu)	Rec Wire Gauge (75° C Cu)	Rec Wire Gauge (90° C Cu)	Maximum Over-current Rating*
Q4SD-X36K	0	27.9	10	10	45	-	-	-	-	-	-	-	-	-	-	-	-	-	-
	5	52.9	6	6	60	23.6	10	10	40	29.3	10	10	10	30	-	-	-	-	-
	8	67.5	4	4	70	23.6	10	10	40	43.7	6	8	8	45	-	-	-	-	-
	10	77.9	3	4	80	23.6	10	10	40	54.3	6	6	8	60	-	-	-	-	-
	15	102.9	1	2	110	23.6	10	10	40	54.3	6	6	8	60	25	10	10	10	30
	20	127.9	00	1	150	23.6	10	10	40	54.3	6	6	8	60	50	6	8	8	60
Q4SD-X48K	0	36.7	8	8	60	-	-	-	-	-	-	-	-	-	-	-	-	-	-
	5	61.7	4	6	80	30.7	8	8	50	31.2	8	8	8	35	-	-	-	-	-
	8	76.3	3	4	90	30.7	8	8	50	45.6	6	8	8	50	-	-	-	-	-
	10	86.7	2	3	100	30.7	8	8	50	56.8	4	6	6	60	-	-	-	-	-
	15	111.7	0	2	125	30.7	8	8	50	56.8	4	6	6	60	25	10	10	10	30
	20	136.7	00	1	150	30.7	8	8	50	56.8	4	6	6	60	50	6	8	8	60
Q4SD-X60K	0	42.5	6	8	70	-	-	-	-	-	-	-	-	-	-	-	-	-	-
	5	67.5	4	4	90	36.5	8	8	60	31.8	8	8	8	35	-	-	-	-	-
	8	82.1	3	4	100	36.5	8	8	60	46.4	6	8	8	50	-	-	-	-	-
	10	92.5	2	3	110	36.5	8	8	60	56.8	4	6	8	60	-	-	-	-	-
	15	117.5	0	1	125	36.5	8	8	60	56.8	4	6	6	60	25	10	10	10	30
	20	142.5	00	0	150	36.5	8	8	60	56.8	4	6	6	60	50	6	8	8	60

*When overcurrent rating exceeds 60, internal circuit breakers must be installed in addition to branch circuit protection at distribution panel.

HEATER APPLICATION MATRIX

Model Number	H3HK-005H-01	H3HK-008H-01	H3HK-010H-01	H3HK-015H-01	H3HK-020H-01	H3HK-015H-21	H3HK-020H-21
Q4S() -036K	X	X	X(2)	X(2)	NA	X	917173
Q4S() -048K	X(2)	X(2)	X(2)	X(3)	X(3)	X(1)	NA
Q4S() -060K	X(2)	X(2)	X(2)	X(3)	X(3)	X(1)	X(1)

NA = Not Applicable.

() = Number of internal circuit breaker kits required.

IDENTIFICATION CODE

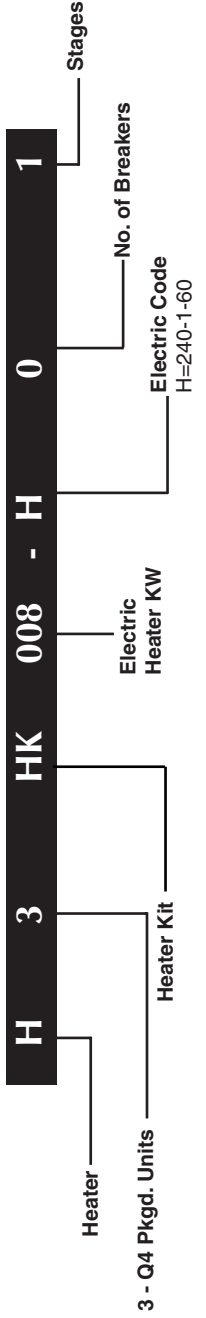

ACCESSORIES

Description	Part Number
Roof Curb (8")	547830
Roof Curb (14")	547831
Roof Curb (18")	547850
Roof Curb (24")	547851
Filter Rack, All Downflow Applications (not required with economizer)	547885
Filter Kit (not required with economizer) for Horizontal Applications Q4SA 030, 036, 042	547887
Filter Kit (not required with economizer) for Horizontal Applications Q4SA 048 - 060	547888
Universal Hard Start Kit	912933
Low Pressure Switch Kit	913551
High Pressure Switch Kit	913550
Low Ambient Kit	913549A
P-Trap Kit	913810
Outdoor Thermostat Kit	913852



CERTIFICATION APPLIES
ONLY WHEN THE
COMPLETE SYSTEM
IS LISTED WITH ARI

We Encourage
Professionalism



Through Technician
Certification by NATE



Before purchasing this appliance, read important energy cost and efficiency information available from your retailer. Specifications and illustrations subject to change without notice and without incurring obligations.

Maytag is a registered trademark of the Maytag Corporation and is used under license.

994B-0306 (Replaces 994B-1105)

Printed in U.S.A. (03/06)