

⚠ WARNING:

If the information in these instructions is not followed exactly, a fire or explosion may result, causing death, personal injury, or property damage.

⚠ FOR YOUR SAFETY!

- Do not store or use gasoline or other flammable vapors and liquids in the vicinity of this or any other appliance. To do so may result in an explosion or fire.
- Installation and service must be performed by a qualified installer, service agency, or the gas supplier.

WHAT TO DO IF YOU SMELL GAS

- Do not try to light any appliance.
- Do not touch any electrical switch; do not use any phone in your building.
- Immediately call your gas supplier from a neighbor's phone. Follow the gas supplier's instructions.
- If you cannot reach your gas supplier, call the fire department.
- Do not return to your home until authorized by the gas supplier or fire department.

Do not destroy manual. Please read carefully and keep in a safe place for future reference.

⚠ WARNING:

This water heater is not suitable for use in manufactured (mobile) homes.



The new degree of comfort.™

Rheem Tankless Rack System (RTRS)

Installation Manual

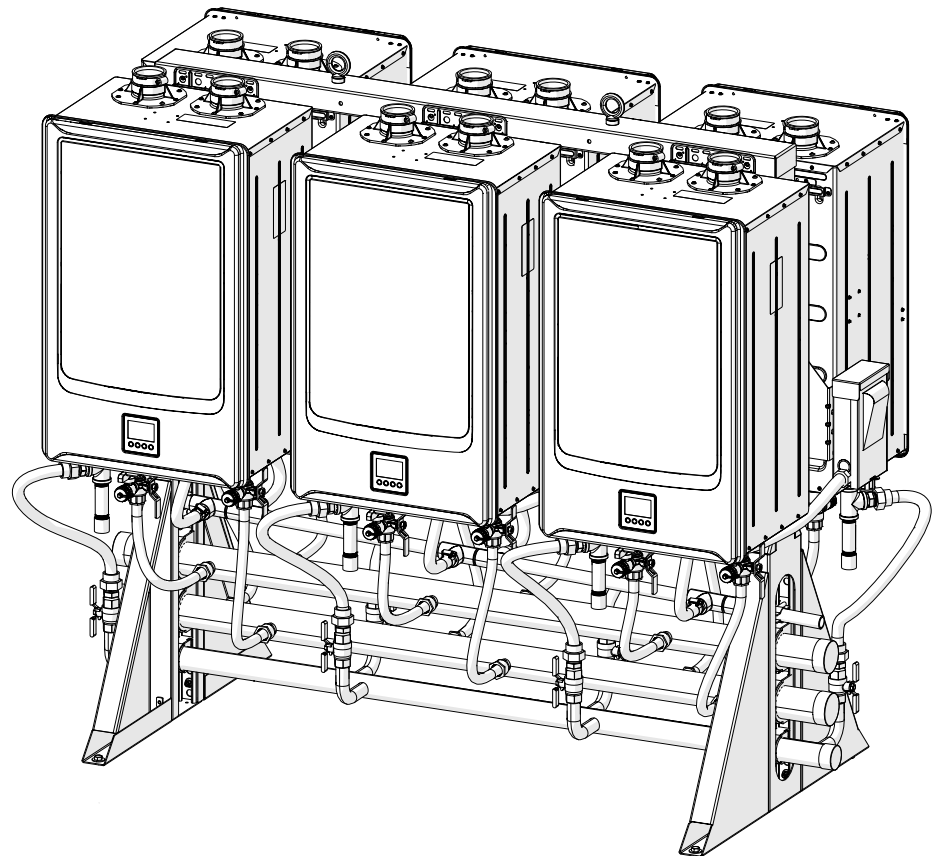

CONTENTS

2.....IMPORTANT SAFETY INFORMATION
9.....DESCRIPTION
10.....RTRS PART NOS. AND MAIN COMPONENTS
12.....SPECIFICATIONS
20.....CLEARANCES
21.....HOISTING (LIFTING LUGS)
22.....SECURING THE RACKS
24.....VENTING OPTIONS

PLUMBING

25.....RELIEF VALVE PIPING
25.....PIPING FOR MULTIPLE RACKS
26.....PARALLEL PIPING DRAWING
27.....END CAPS / CONNECTIONS
28.....CONDENSATE DRAIN

28.....CONDENSATE MANIFOLD
29.....CHECKLIST FOR PLUMBING

GAS SUPPLY

29.....INSTALLATION OF GAS SUPPLY

ELECTRICAL

30.....ELECTRICAL CONNECTIONS
31.....ELECTRICAL INDOOR (PRE-WIRED ELECTRICAL ASSEMBLY)
33.....ELECTRICAL OUTDOOR (PRE-WIRED ELECTRICAL ASSEMBLY)
35.....MULTIPLE UNITS CONTROLS
37.....FINAL CHECKLIST
38.....REPLACEMENT PARTS
41.....IF YOU NEED SERVICE
42.....LIMITED WARRANTY

IMPORTANT SAFETY INFORMATION

Your safety and the safety of others are very important. There are many important safety messages in this manual and on your appliance. Always read and obey all safety messages.



This is the safety alert symbol. Recognize this symbol as an indication of Important Safety Information! This symbol alerts you to potential hazards that can kill or hurt you and others.

All safety messages will follow the safety alert symbol and either the word “DANGER,” “WARNING,” “CAUTION,” or “NOTICE.”

These words mean:

▲ DANGER: An imminently hazardous situation that will result in death or serious injury.

▲ WARNING: A potentially hazardous situation that can result in death or serious injury and/or damage to property.

▲ CAUTION: A potentially hazardous situation that may result in minor or moderate injury.

NOTICE: Attention is called to observe a specified procedure or maintain a specific condition.

▲ WARNINGS:

- This tankless system is not suitable for use in manufactured (mobile) homes!
- Improper installation, adjustment, alteration, service, or maintenance can cause death, personal injury, or property damage. Follow the instructions in this manual.

Read All Instructions Before Using

Be sure to read and understand the entire Use and Care Manual before attempting to install or operate this tankless system. It may save you time and money. Pay particular attention to the Safety Instructions. Failure to follow these warnings could result in death or serious bodily injury. Should you have problems understanding the instructions in this manual, or have any questions, STOP and get help from a qualified service technician or the local gas utility.

IMPORTANT SAFETY INFORMATION

Water Heater Venting Safety

▲ DANGER:

- Failure to install and properly vent the water heater to the outdoors as outlined in the “Venting” section of the Installation Instructions in this manual will result in death from fire, explosion, or asphyxiation from carbon monoxide. NEVER operate this water heater unless it is properly vented and has an adequate air supply for proper operation.
- Be sure to inspect the vent terminal, the air intake, and the coaxial vent system on the water heater for proper installation at initial start-up and at least annually thereafter. Refer to the “Care and Cleaning” section of this manual for more information regarding coaxial vent system inspection.

▲ WARNINGS:

- Gasoline and other flammable liquids, materials, and vapors (including paint thinners, solvents, and adhesives) are extremely dangerous. DO NOT handle, use, or store gasoline or other flammable or combustible materials anywhere in the vicinity of a water heater or any other appliance. Be sure to read and follow the labels on the water heater, as well as the warnings printed in this manual. Failure to do so can result in death, bodily injury, or property damage.
- Combustible construction refers to adjacent walls and ceilings and should not be confused with combustible or flammable products and materials. Combustible materials, such as clothing, cleaning materials, or flammable liquids, should never be stored in the vicinity of this or any gas appliance. Fire or explosion can occur causing death, personal injury, and/or product damage.
- Follow vent manufacturer’s instructions for venting installation, including additional clearances from combustibles, to avoid conditions that can lead to death, personal injury, and/or property damage.
- Use tankless water heater manufacturer-approved Schedule 40 PVC (foam core is not permitted at any time), Schedule 80 PVC, CPVC, ABS, UL 1738-listed Category III Stainless Steel, or InnoFlue® PP. No other vent material is permitted. For Canada, installations must follow ULC S636 for exhaust venting.
- Moisture in the flue gas will condense as it leaves the vent terminal. In cold weather this condensate can freeze on the exterior wall, under the eaves, and on surrounding objects. Some discoloration to the exteri-

▲ DANGER



▲ Vapors from flammable liquids will explode and catch fire causing death or severe burns.
Do not use or store flammable products such as gasoline, solvents or adhesives in the same room or area near the water heater.

Keep flammable products:

1. far away from heater,
2. in approved containers,
3. tightly closed and
4. out of children’s reach.

Water heater has a main burner flame.
The main burner flame:

1. which can come on at any time and
2. will ignite flammable vapors.

Vapors:

1. cannot be seen,
2. are heavier than air,
3. go a long way on the floor and
4. can be carried from other rooms to the main burner flame by air currents.

Installation:
Do not install water heater where flammable products will be stored or used unless the main burner flame is at least 18" above the floor. This will reduce, but not eliminate, the risk of vapors being ignited by the main burner flame.

Read and follow water heater warnings and instructions. If owners manual is missing, contact the retailer or manufacturer.

or of the building is to be expected. However, improper location or installation can result in severe damage to the structure or exterior finish of the building.

- For systems with multiple exhaust vents, a minimum distance between vent terminations must be maintained to prevent recirculation of vent gases. Maintain a center-to-center distance between vent terminations of 19 in. (48 cm) for two-exhaust vents. Maintain a center-to-center distance between vent terminations of 21 in. (53 cm) for installation of three or more exhaust vents.

▲ CAUTIONS:

- Ensure that the appliance vent is securely attached to the water heater collar.
- Condensate must drain away from the water heater and should not be allowed to drain back into any part of the vent system.
- DO NOT operate without the condensate trap connected to the vent and routed to the proper drain.
- Follow the vent manufacturer’s installation instructions because the design might vary from manufacturer to manufacturer.

IMPORTANT SAFETY INFORMATION

Water Supply Safety

⚠ DANGERS:

- **WATER TEMPERATURE SETTINGS**
 - Safety and energy conservation are factors to be considered when selecting the water temperature setting of a water heater's remote control. Water temperatures above 125°F (52°C) can cause death or severe burns from scalding. Be sure to read and follow the warnings outlined on the pictured label.
- There is a hot water scald potential if the water temperature is set too high. Households with small children, the disabled, or elderly persons may require a 120°F (49°C) or lower temperature setting to prevent contact with "HOT" water.
- Before manually operating the relief valve, make certain no one will be exposed to the danger of the hot water released by the valve. The water may be hot enough to create a scald hazard. The water should be released into a suitable drain to prevent injury or property damage.
- Failure to perform the recommended Routine Preventive Maintenance can harm the proper operation of this water heater, which can cause carbon monoxide dangers, excessive hot water temperatures, and other potentially hazardous conditions.

⚠ WARNINGS:

- **IMPORTANT: DO NOT** apply heat to the HOT or COLD water connections. If sweat connections are used, sweat tubing to adapter before fitting adapter to the water connections on heater. Any heat applied to the water supply fittings will permanently damage the internal components of the water heater.
- In case the pipe insulation is not rated for the appropriate weather conditions, install electric heat tracing or equivalent to prevent freezing of the pipes. **DO NOT** insulate or block the drain valve on the hot outlet fitting. If the pipes are allowed to freeze, the water heater and the pipes may malfunction or leak due to freezing water.

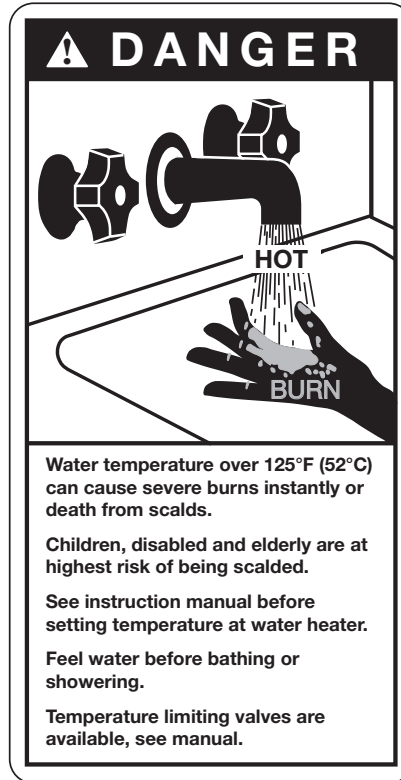

⚠ CAUTIONS:

- This water heater must only be used with the following water supply system conditions:
 - With clean, potable water free of corrosive chemicals, sand, dirt, or other contaminants.
 - With inlet water temperatures above 32°F (0°C), but not exceeding 120°F (49°C).
 - **DO NOT** reverse the hot and cold water connections. The water heater will not operate.
- Even when drained properly, a small amount of water will remain in the water heater. In cold weather conditions, this water can freeze. If this happens, allow the defrost protection on the heater at least 30 minutes to melt the frozen water or the water heater may not work properly.

Time/Temperature Relationship in Scalds

Water Temperature	Time to Produce a Serious Burn
120°F (49°C)	More than 5 minutes
125°F (52°C)	1 1/2 to 2 minutes
130°F (54°C)	About 30 seconds
135°F (57°C)	About 10 seconds
140°F (60°C)	Less than 5 seconds
145°F (63°C)	Less than 3 seconds
150°F (66°C)	About 1 1/2 seconds
155°F (68°C)	About 1 second

Table courtesy of Shriners Burn Institute

Temperature Conversion Chart °F/°C								
85	100	102	104	106	108	110	112	°F
29	38	39	40	41	42	43	44	°C
<hr/>								
114	116	118	120	125	130	140		°F
46	47	48	49	52	54	60		°C

IMPORTANT SAFETY INFORMATION

Natural Gas and Liquefied Petroleum Safety

⚠️ DANGERS:

- Never attempt to convert the water heater from natural gas to LP. The water heater should only use the fuel type in accordance with listing on data plate—natural gas for natural gas units and LP for LP units. Any other fuel usage will result in death or serious personal injury from fire and/or explosion. This water heater is not certified for any other fuel type.
- Both natural gas and propane (LP) have an odorant added to aid in detecting a gas leak. Some people may not physically be able to smell or recognize this odorant. If you are unsure or unfamiliar with the smell of natural gas or LP, ask the gas supplier. Other conditions, such as “odorant fade,” which causes the odorant to diminish in intensity, can also hide or camouflage a gas leak.
- Water heaters using LP gas are different from natural gas models. A natural gas water heater will not function safely on LP and vice versa.
- LP water heaters should not be installed below grade (for example, in a basement) if such installation is prohibited by federal, state, and/or local laws, rules, regulations, or customs.
- LP must be used with great caution. It is heavier than air and will collect first in lower areas, making it hard to detect at nose level.
- Before attempting to light the water heater, make sure to look and smell for gas leaks. Use a soapy solution to check all gas fittings and connections. Bubbling at a connection indicates a leak that must be corrected. When smelling to detect a gas leak, be sure to also sniff near the floor.
- Gas detectors are recommended in LP and natural gas applications and their installation should be in accordance with the detector manufacturer’s recommendations and/or local laws, rules, regulations, or customs.
- Combustible materials, such as clothing, cleaning materials, or flammable liquids, must not be placed in the vicinity of the water heater.
- If a gas leak is present or suspected:
 - DO NOT attempt to find the cause yourself.
 - Never use an open flame to test for gas leaks. The gas can ignite resulting in death, personal injury, or property damage.
 - Follow the steps listed under “What to Do If You Smell Gas” found on the front cover of this manual.

⚠️ WARNINGS:

- The installation of gas piping must conform to local utility company requirements and/or in the absence of local codes, use the latest edition of National Fuel Gas Code (NFGC), ANSI Z223.1/NFPA 54, or CAN/CSA B149.1, Natural Gas and Propane Installation Code.
- If inlet gas pressure is out of allowable range [4.0” w.c. (1.0kPa) – 10.5” w.c. (2.6kPa)] for Natural Gas, or [8.0” w.c. (2.0kPa) – 13.0” w.c. (3.2kPa)] for LP gas, a gas pressure regulator must be installed to maintain the allowable inlet gas pressure.
- Should overheating occur or the gas supply fail to shut off, turn off the manual gas control valve to the water heater.

⚠️ CAUTIONS:

- DO NOT attempt repair of electrical wiring, gas piping, remote control, burners, vent connectors, or other safety devices. Refer repairs to qualified service personnel.
- Turn off the manual gas shut-off valve if the water heater has been subjected to overheating, fire, flood, physical damage, or if the gas supply fails to shut off.
- DO NOT turn on the water heater unless the water and gas supplies are completely opened.

IMPORTANT SAFETY INFORMATION

Before operating this water heater, be sure to read and follow the instructions on the label pictured below and all other labels on the water heater, as well as the warnings printed in this manual. Failure to do so can result in unsafe operation of the water heater, resulting in death, personal injury, or property damage. Should you have any problems reading or following the instructions in this manual, STOP and get help from a qualified service technician.

FOR YOUR SAFETY READ BEFORE OPERATING

WARNING : If you do not follow these instructions exactly, a fire or explosion may result causing property damage, personal injury or loss of life.

A. This appliance does not have a pilot. It is equipped with an ignition device which automatically lights the burner. Do not try to light the burner by hand.

B. BEFORE OPERATING smell all around the appliance area for gas. Be sure to smell next to the floor because some gas is heavier than air and will settle on the floor.

WHAT TO DO IF YOU SMELL GAS

● Do not try to light any appliance. ● Do not touch any electric switch; do not use any phone in your building. ● Immediately call your gas supplier from a neighbor's phone. Follow the gas supplier's instructions. ● If you cannot reach your gas supplier, call the fire department.

● Do not return to your home until authorized by the gas supplier or fire department.

C. Use only your hand to push in or turn the gas control knob. Never use tools. If the knob will not push in or turn by hand, don't try to repair it, call a qualified service technician. Force or attempted repair may result in a fire or explosion.

D. Do not use this appliance if any part has been under water. Immediately call a qualified service technician to inspect the appliance and to replace any part of the control system and any gas control which has been under water.

31-16962 (0)

OPERATING INSTRUCTIONS

1. STOP! Read the safety information above on this label.

2. Turn off all electric power to the appliance.

3. Do not attempt to light the burner by hand.

4. Turn the Gas Shutoff Valve located on the outside of the unit clockwise  to the "OFF" position.

GAS SHUTOFF
VALVE



OPEN



CLOSE

5. Wait five (5) minutes to clear out any gas. If you then smell gas, STOP! Follow "B" in the safety information above on this label. If you don't smell gas, go to the next step.

6. Turn the Gas Shutoff Valve located on the outside of the unit counterclockwise  to the "ON" position.

7. Turn on all electric power to the appliance.

8. If the appliance will not operate, follow the instructions "To Turn Off Gas To Appliance" and call your service technician or gas supplier.

TO TURN OFF GAS TO APPLIANCE

1. Turn off all electric power to the appliance if service is to be performed.

2. Turn the Gas Shutoff Valve located on the outside of the unit clockwise  to the "OFF" position.

IMPORTANT SAFETY INFORMATION

Electrical Safety

⚠ DANGER:

- Shock Hazard – Make sure the electrical power to the water heater is off to avoid electric shock that will result in death or serious personal injury.

⚠ WARNINGS:

- For your safety, the information in this manual must be followed to minimize the risk of fire, explosion, or electric shock that can result in death, personal injury, and/or property damage.
- Field wiring connections and electrical grounding must comply with local codes or, in the absence of local codes, with the latest edition of the National Electrical Code, ANSI/NFPA 70, or in Canada, Canadian Electrical Code, CAN/CSA C22.1, Part 1.

⚠ CAUTIONS:

- Label all wires prior to disconnecting for service. Wiring errors can cause dangerous and improper operation. Verify correct operation after servicing.
- For your safety, burner inspection and cleaning should be performed only by qualified service personnel.
- Make certain the power to the water heater is OFF before removing the unit cover panel. Exposed electrical components and moving parts can cause personal injuries.
- For your safety, DO NOT attempt repair of electrical wiring, gas piping, remote control, burners, vent connectors, or other safety devices. Refer repairs to qualified service personnel.

For Installations in the State of California

California law requires that water heaters must be braced, anchored, or strapped to resist falling or horizontal displacement due to earthquake motions. For water heaters up to 52-gallon capacity, a brochure with generic earthquake bracing instructions can be obtained from: Office of the State Architect, 1102 Q Street, Suite 5100, Sacramento, CA 95814, or you may call 916-445-8100 or ask a water heater dealer.

However, applicable local codes shall govern installation. For residential water heaters of a capacity greater than 52 gallons or tankless-style, consult the local building jurisdiction code for acceptable bracing procedures.

IMPORTANT SAFETY INFORMATION

General Installation and Maintenance Safety

⚠ WARNINGS:

- This water heater must be installed in accordance with these instructions, local codes, utility company requirements and/or in the absence of local codes, use the latest edition of the American National Standard/National Fuel Gas Code (NFGC), ANSI Z223.1 and National Fire Protection Association, NFPA 54, or in Canada, CAN/CSA B149.1, Natural Gas and Propane Installation Code, and the latest edition of the National Electrical Code, ANSI/NFPA 70, or in Canada, Canadian Electrical Code, CAN/CSA C22.1, Part 1.
- If local codes require the application of external insulation blanket kits, carefully follow the manufacturer's installation instructions included with the kit. Only use blanket kits that are approved for use with your water heater.
- For your safety, **DO NOT** attempt to disassemble this water heater for any reason. Improper adjustments, alterations, service, or maintenance can cause death, personal injury, or property damage.

Safety Precautions

- Read this manual entirely before installing and/or operating the water heater.
- Use this water heater only for its intended purpose as described in the Use and Care Manual.
- Have the installer show you the location of the gas shut-off valve and how to shut it off if necessary. Turn off the manual shut-off valve if the water heater has been subjected to overheating, fire, flood, physical damage, or if the gas supply fails to shut off.
- Be sure your water heater is properly installed in accordance with local codes and the provided installation instructions.
- **DO NOT** attempt to repair or replace any part of your water heater unless it is specifically recommended in this manual. All other servicing should be referred to a qualified service technician.

Product Information

For Your Records

Write down and save the following product information along with the original sales slip and/or canceled check. The model and serial numbers can be found on the top label on the right side of the water heater.

MODEL NUMBER:
SERIAL NUMBER:
DATE OF INSTALLATION:
INSTALLING COMPANY/PHONE NUMBER:
PLUMBING CONTRACTOR/PHONE NUMBER:
See page 41 for additional service information.

DESCRIPTION

Rheem Tankless Rack Systems (RTRS) include wall hanging and free standing configurations. The wall hanging rack systems are available for 2 or 3 water heaters. Free standing rack systems are available for 2, 3, 4, 5 or 6 water heaters.

The RTRS can be ordered with Rheem's Common Venting System, which consists of Polypropylene venting. Up to 12 units can share the same vent system with the RTRS.

The RTRS features design details that make installation simple and straightforward.



- **Maneuverability:** Fits, fully assembled, through standard 32-inch doorways and on elevators.
- **Flexibility:** Available in both wall-hanging or free-standing design for indoor and outdoor installations. Preassembled gas and water manifolds are properly sized to maintain optimum performance.
- **The racks are constructed of powder-coated galvanized steel to stand up to the most demanding commercial environments, while minimizing weight.**

NOTE:

The RTRS is designed to be used with Rheem tankless water heaters only. **DO NOT** mount non-Rheem water heaters on the RTRS.

RTRS PART NOS. AND MAIN COMPONENTS

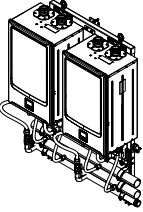
Tankless Rack Wall Hanging

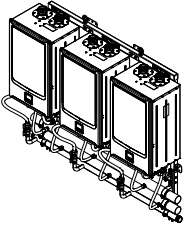
Part No.*	Rack Type	Configuration	Illustration
RTRS-WH220DVLN	2-unit interior wall hanging rack, NG		
RTRS-WH220XLN	2-unit exterior wall hanging rack, NG		
RTRS-WH220DVLP	2-unit interior wall hanging rack, LP		
RTRS-WH220XLP	2-unit exterior wall hanging rack, LP		
RTRS-WH330DVLN	3-unit interior wall hanging rack, NG		
RTRS-WH330XLN	3-unit exterior wall hanging rack, NG		
RTRS-WH330DVLP	3-unit interior wall hanging rack, LP		
RTRS-WH330XLP	3-unit exterior wall hanging rack, LP		

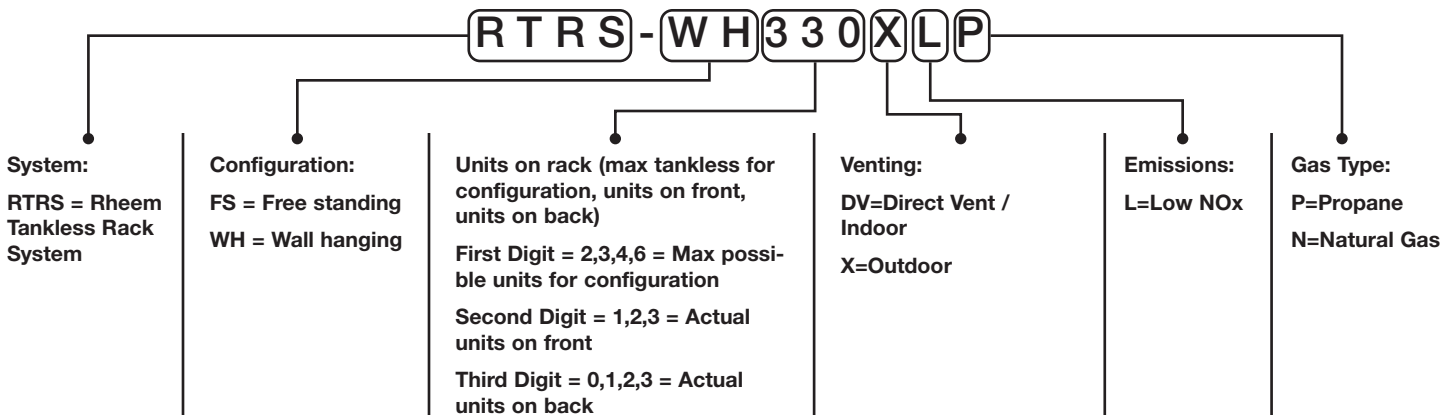

RTRS PART NOS. AND MAIN COMPONENTS

Tankless Rack Freestanding

Part No.*	Rack Type	Configuration	Illustration
RTRS-FS411DVLN	2-unit interior free standing rack, NG		
RTRS-FS411XLN	2-unit exterior free standing rack, NG		
RTRS-FS411DVLP	2-unit interior free standing rack, LP		
RTRS-FS411XLP	2-unit exterior free standing rack, LP		
RTRS-FS420DVLN	2-unit INLINE interior free standing rack, NG		
RTRS-FS420XLN	2-unit INLINE exterior free standing rack, NG		
RTRS-FS420DVLP	2-unit INLINE interior free standing rack, LP		
RTRS-FS420XLP	2-unit INLINE exterior free standing rack, LP		
RTRS-FS630DVLN	3-unit INLINE interior free standing rack, NG		
RTRS-FS630XLN	3-unit INLINE exterior free standing rack, NG		
RTRS-FS630DVLP	3-unit INLINE interior free standing rack, LP		
RTRS-FS630XLP	3-unit INLINE exterior free standing rack, LP		
RTRS-FS421DVLN	3-unit interior free standing rack, NG		
RTRS-FS421XLN	3-unit exterior free standing rack, NG		
RTRS-FS421DVLP	3-unit interior free standing rack, LP		
RTRS-FS421XLP	3-unit exterior free standing rack, LP		
RTRS-FS422DVLN	4-unit interior free standing rack, NG		
RTRS-FS422XLN	4-unit exterior free standing rack, NG		
RTRS-FS422DVLP	4-unit interior free standing rack, LP		
RTRS-FS422XLP	4-unit exterior free standing rack, LP		
RTRS-FS632DVLN	5-unit interior free standing rack, NG		
RTRS-FS632XLN	5-unit exterior free standing rack, NG		
RTRS-FS632DVLP	5-unit interior free standing rack, LP		
RTRS-FS632XLP	5-unit exterior free standing rack, LP		
RTRS-FS633DVLN	6-unit interior free standing rack, NG		
RTRS-FS633XLN	6-unit exterior free standing rack, NG		
RTRS-FS633DVLP	6-unit interior free standing rack, LP		
RTRS-FS633XLP	6-unit exterior free standing rack, LP		

System:

RTRS = Rheem Tankless Rack System

Configuration:

FS = Free standing
WH = Wall hanging

Units on rack (max tankless for configuration, units on front, units on back)

First Digit = 2,3,4,6 = Max possible units for configuration

Second Digit = 1,2,3 = Actual units on front

Third Digit = 0,1,2,3 = Actual units on back

Venting:

DV=Direct Vent / Indoor

X=Outdoor

Emissions:

L=Low NOx

Gas Type:

P=Propane

N=Natural Gas

SPECIFICATIONS

2 Unit Wall Hanging

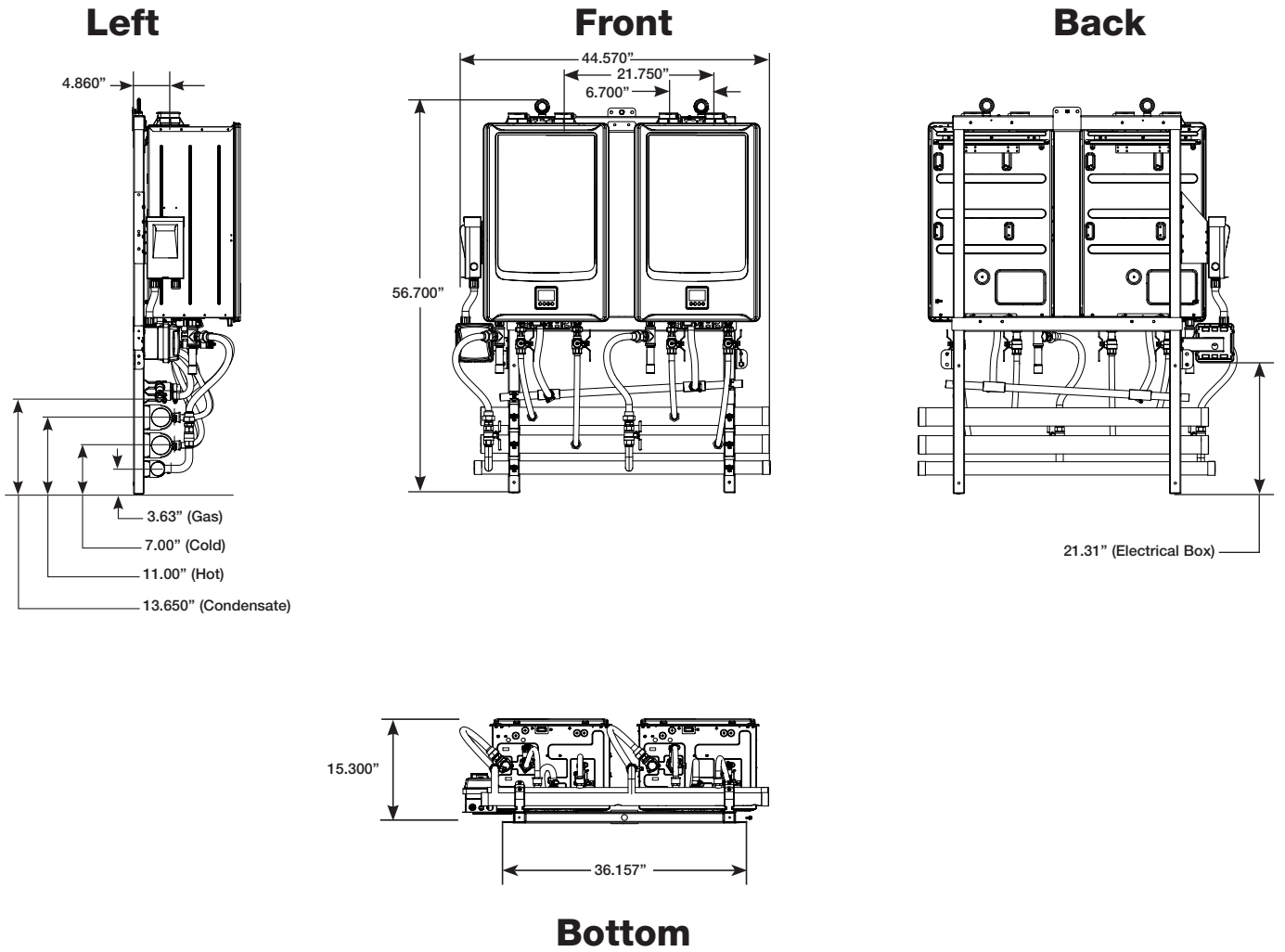

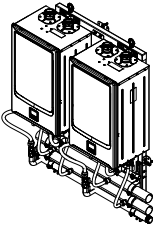
<i>Model</i>	<i>Configuration</i>	<i>Illustration</i>
RTRS-WH220		

SPECIFICATIONS

2 Unit Wall Hanging

Model	RTRS-WH2*
Water Heater Model	RTGH-CS11i (NG/LP, Indoor/Outdoor)
Crate Dimensions (HxLxD) - in	26 X 54 X 66
Weight - Fully Assembled - lbs	250
Weight - Shipping (total) - lbs	350
Rack Frame	
Frame Material	16 Gauge Galvanized Steel
Frame Finish	Powder Coat
Color	Gray
Water, Gas and Condensate Connections	
Hot Water Trunk Line Diameter	2 - 1/2"
Cold Water Trunk Line Diameter	2 - 1/2"
Hot Water Trunk Line Material	Rigid Copper
Cold Water Trunk Line Material	Rigid Copper
Water Trunk Connection Type	2 - 1/2" PIPE
Gas Trunk Line Diameter	1-1/2"
Gas Trunk Connection Type	1-1/2" MNPT
Gas Trunk Line Material	Sch 40 Steel
Gas Branch Line Material	Sch 40 Steel
Condensate Trunk Line Diameter	3/4"
Condensate Trunk Line Material	Sch-40 PVC
Condensate Trunk Connection Type	3/4" Pipe
Electrical	
Voltage	120V AC / 60Hz
Maximum Current (Amperes)	4
BTU and Flow Rates	
Number of Tankless Water Heaters	2
Flow rate @ 70°F rise (gpm)	11.1
Flow rate @ 100° F rise (gpm)	7.7
Minimum input rate (Btuh)	11,000
Maximum input rate (Btuh)	399,800

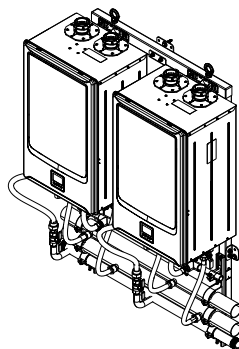

*Refer to page 10 for Part No.

SPECIFICATIONS

3 Unit Wall Hanging

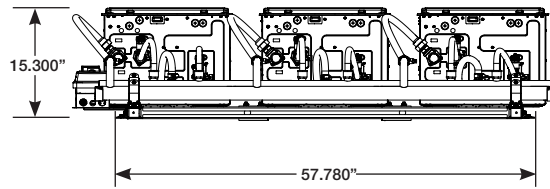
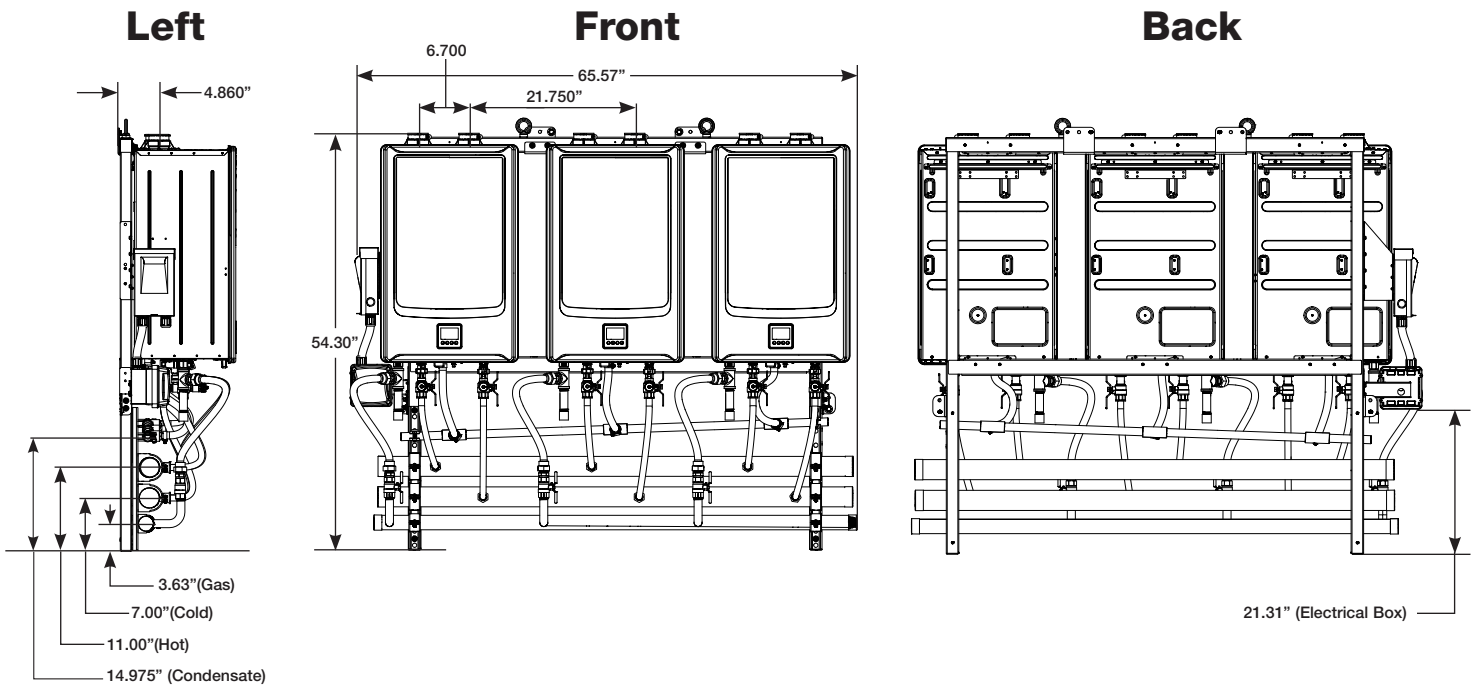

Bottom

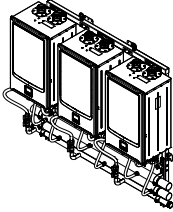
<i>Model</i>	<i>Configuration</i>	<i>Illustration</i>
RTRS-WH330		

SPECIFICATIONS

3 Unit Wall Hanging

<i>Model</i>	<i>RTW-WH3*</i>
Water Heater Model	RTGH-CS11i (Indoor NG/LP, Indoor/Outdoor)
Crate Dimensions (HxLxD) - in	26 X 74 X 66
Weight - Fully Assembled - lbs	355
Weight - Shipping (total) - lbs	475
Rack Frame	
Frame Material	16 Gauge Galvanized Steel
Frame Finish	Powder Coat
Color	Gray
Water, Gas and Condensate Connections	
Hot Water Trunk Line Diameter	2 - 1/2"
Cold Water Trunk Line Diameter	2 - 1/2"
Hot Water Trunk Line Material	Rigid Copper
Cold Water Trunk Line Material	Rigid Copper
Water Trunk Connection Type	2 - 1/2" PIPE
Gas Trunk Line Diameter	1-1/2"
Gas Trunk Connection Type	1-1/2" MNPT
Gas Trunk Line Material	Sch 40 Steel
Gas Branch Line Material	Sch 40 Steel
Condensate Trunk Line Diameter	3/4"
Condensate Trunk Line Material	Sch-40 PVC
Condensate Trunk Connection Type	3/4" Pipe
Electrical	
Voltage	120V AC / 60Hz
Maximum Current (Amperes)	6
BTU and Flow Rates	
Number of Tankless Water Heaters	3
Flow rate @ 70°F rise (gpm)	16.6
Flow rate @ 100° F rise (gpm)	11.6
Minimum input rate (Btuh)	11,000
Maximum input rate (Btuh)	599,700

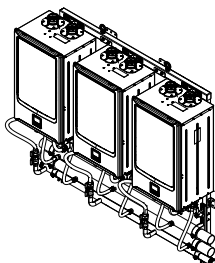



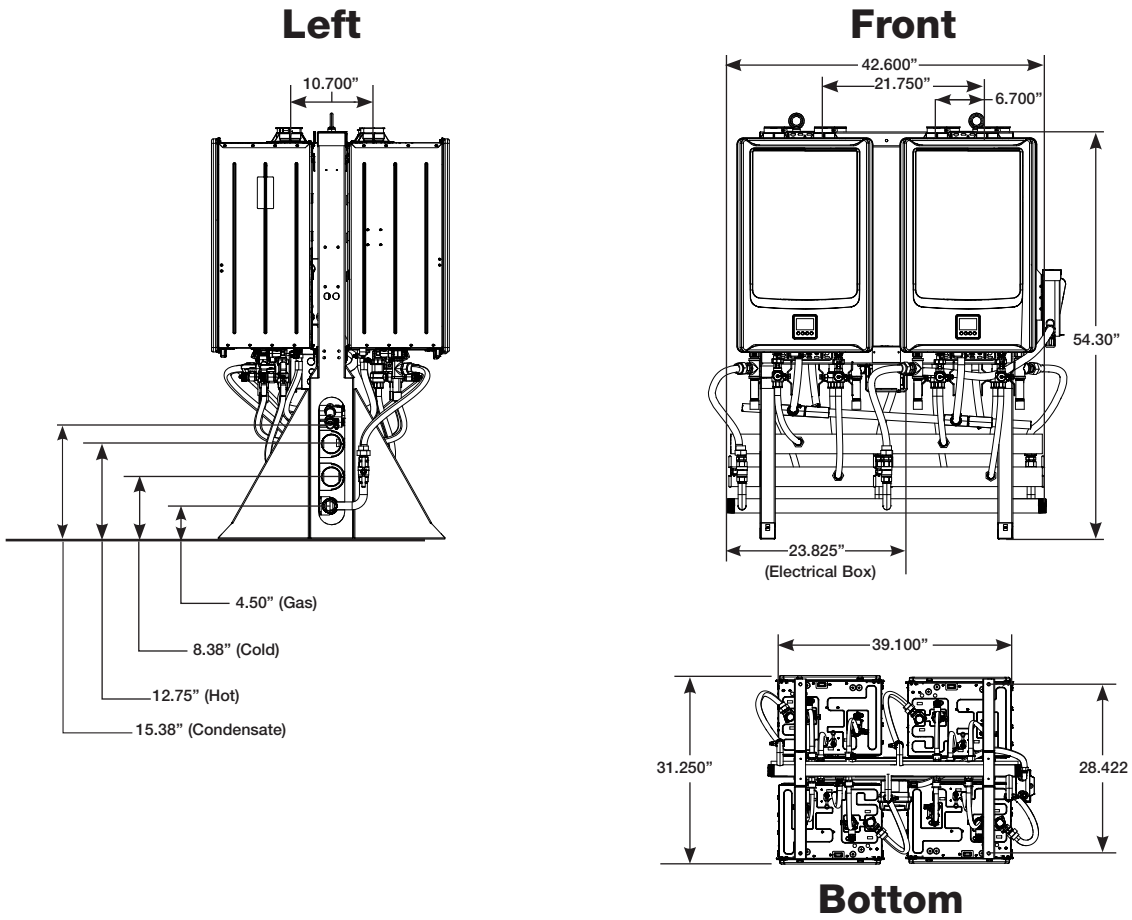

*Refer to page 10 for Part No.

SPECIFICATIONS

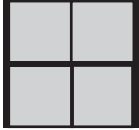
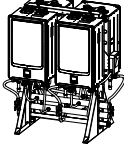
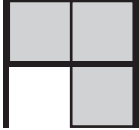
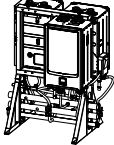
4 Unit Free Standing

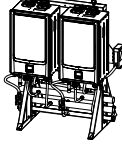

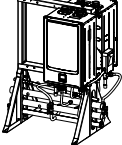
Model	Configuration	Illustration
RTRS-FS422		
RTRS-FS421		
RTRS-FS420	In-line (Facing same direction) 	
RTRS-FS411	Back to Back 	

SPECIFICATIONS

4 Unit Free Standing

<i>Model</i>	<i>RTRS-FS422*</i>	<i>RTRS-FS421*</i>	<i>RTRS-FS420*</i>	<i>RTRS-FS411*</i>
Water Heater Model	RTGH-CS11i (NG/LP, Indoor/Outdoor)			
Crate Dimensions (HxLxD) - in	65 X 55 X 38			
Weight - Fully Assembled - lbs	480	375	270	270
Weight - Shipping (total) - lbs	590	485	380	380
Rack Frame - Specifications				
Frame Material	14 Gauge Galvanized Steel			
Frame Finish	Powder Coat			
Color	Gray			
Water, Gas and Condensate Connections				
Hot Water Trunk Line Diameter	2 - 1/2"			
Cold Water Trunk Line Diameter	2 - 1/2"			
Hot Water Trunk Line Material	Rigid Copper			
Cold Water Trunk Line Material	Rigid Copper			
Water Trunk Connection Type	2 - 1/2" PIPE			
Gas Trunk Line Diameter	1-1/2"			
Gas Trunk Connection Type	1-1/2" MNPT			
Gas Trunk Line Material	Sch 40 Steel			
Gas Branch Line Material	Sch 40 Steel			
Condensate Trunk Line Diameter	3/4"			
Condensate Trunk Material	Sch-40 PVC			
Condensate Trunk Connection Type	3/4" Pipe			
Electric				
Voltage	120V AC/60 Hz			
Maximum Current (Amperes)	8	6	4	
BTU and Flow Rates				
Number of Tankless Water Heaters	4	3	2	
Flow rate @ 70°F rise (gpm)	22.1	16.6	11.1	
Flow rate @ 100°F rise (gpm)	15.5	11.6	7.7	
Minimum input rate (Btuh)	11,000			
Maximum input rate (Btuh)	799,600	599,700	399,800	

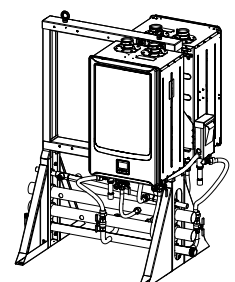
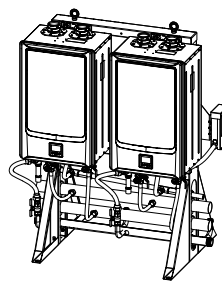
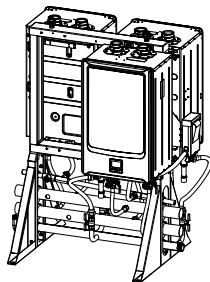
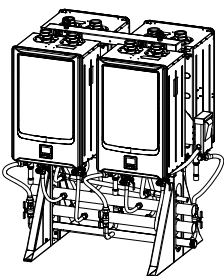

*Refer to page 11 for Part No.

SPECIFICATIONS

6 Unit Free Standing

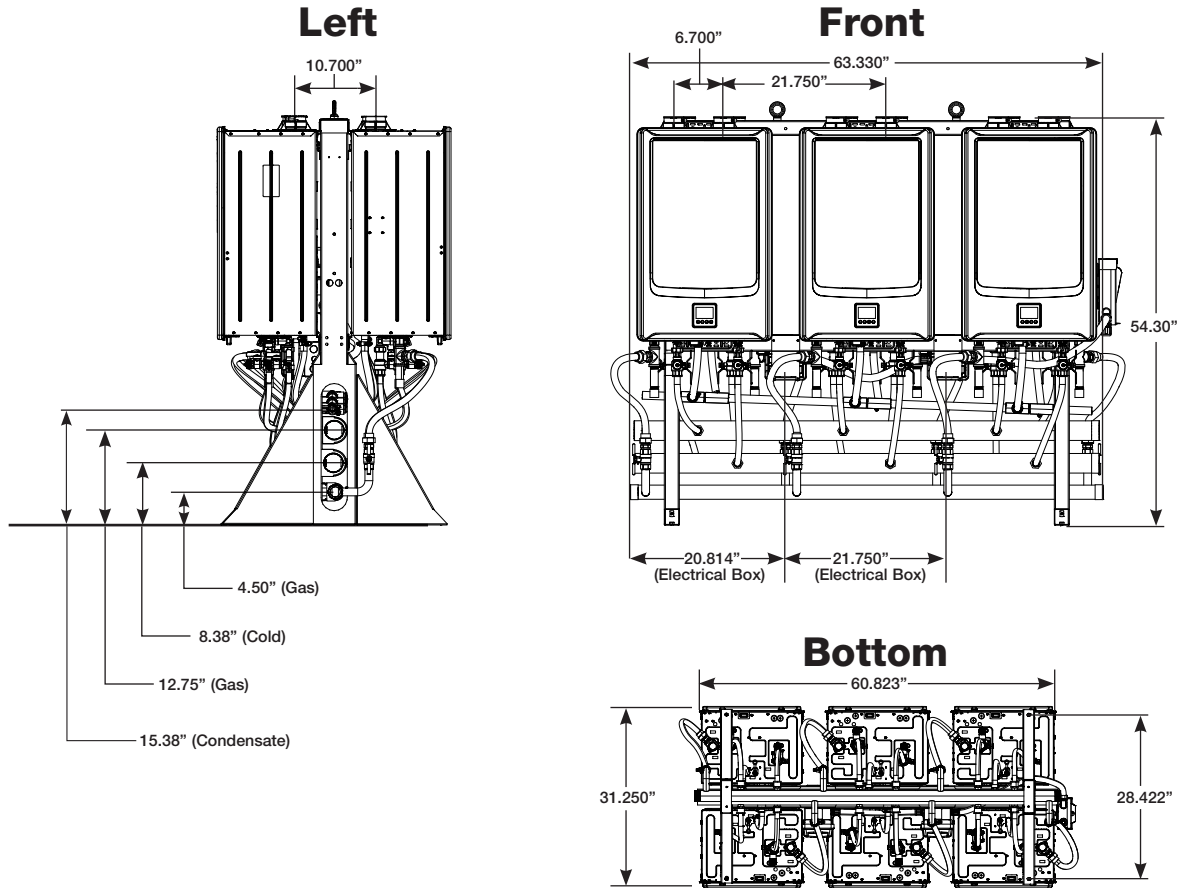

<i>Model</i>	<i>Configuration</i>	<i>Illustration</i>
RTRS-FS633		
RTRS-FS632		
RTRS-FS630		

SPECIFICATIONS

6 Unit Free Standing

<i>Model</i>	<i>RTRS-FS633*</i>	<i>RTRS-FS632*</i>	<i>RTRS-FS630*</i>
Water Heater Model	RTGH-CS11i (NG/LP, Indoor/Outdoor)		
Crate Dimensions (HxLxD) - in	65 X 74 X 38		
Weight - Fully Assembled - lbs	710	605	395
Weight - Shipping (total) - lbs	850	745	535
Rack Frame - Specifications			
Frame Material	14 Gauge Galvanized Steel		
Frame Finish	Powder Coat		
Color	Gray		
Water, Gas and Condensate Connections			
Hot Water Trunk Line Diameter	2-1/2"		
Cold Water Trunk Line Diameter	2-1/2"		
Hot Water Trunk Line Material	Rigid Copper		
Cold Water Trunk Line Material	Rigid Copper		
Water Trunk Connection Type	2-1/2" PIPE		
Gas Trunk Line Diameter	1-1/2"		
Gas Trunk Connection Type	1-1/2" MNPT		
Gas Trunk Line Material	Sch 40 Steel		
Gas Branch Line Material	Sch 40 Steel		
Condensate Trunk Line Diameter	3/4"		
Condensate Trunk Line Material	Sch-40 PVC		
Condensate Trunk Connection Type	3/4" Pipe		
Electric			
Voltage	120V AC/60 Hz		
Maximum Current (Amperes)	12	10	6
BTU and Flow Rates			
Number of Tankless Water Heaters	6	5	3
Flow rate @ 70°F rise (gpm)	33.2	27.6	16.6
Flow rate @ 100°F rise (gpm)	23.2	19.3	11.6
Minimum input rate (Btuh)	11,000		
Maximum input rate (Btuh)	1,199,400	999,500	599,700

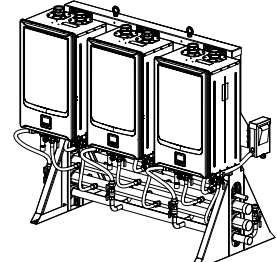
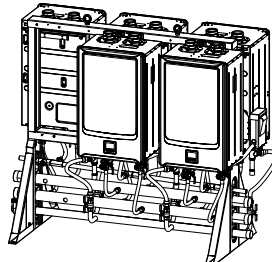
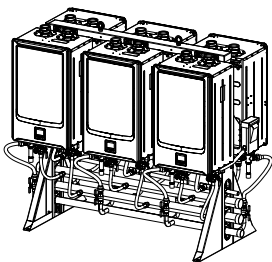

*Refer to page 11 for Part No.

CLEARANCES

Install the rack system so that the clearances shown below (specified for the water heater in the RTGH-CS11i high efficiency commercial condensing tankless water heater use and care manual) are followed.

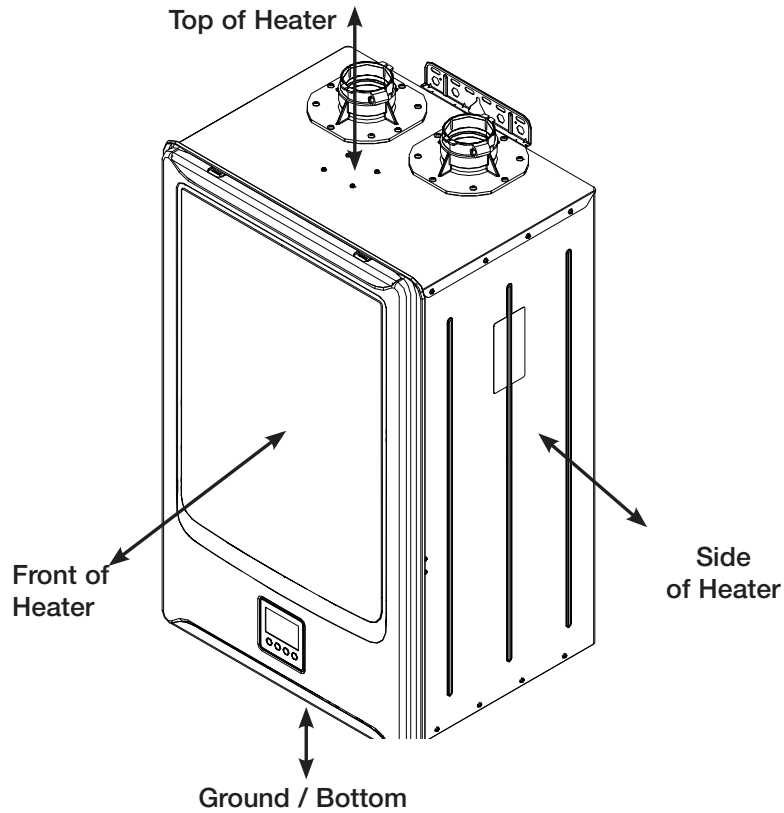

Indoor models: RTGH-CS11i

	<i>To Combustibles and Non-Combustibles inches (mm)</i>
Top of Heater	12 (305)
Back of Heater	0 (zero)
Front of Heater	1/2 (13)
Sides of Heater	1/2 (13)
Ground/Bottom	12 (305)
Vent	0 (zero)

* 0 inches from vent components and condensate drain line.

The clearance for servicing is 24 inches in front of the water heater.

For closet installation, clearance is 6 inches (152 mm from the front of the water heater).

HOISTING (LIFTING LUGS)

Lugs are installed on the top side of the following racks for hoisting and moving. The lines or cables to the lugs should be at a 90° angle. Use a spreader lifting bar to hoist these racks.

Weights of the complete assemblies are available in the Specifications section of this manual.

NOTE:

DO NOT hoist the crate or pallet.

Models Available With Lifting Lugs

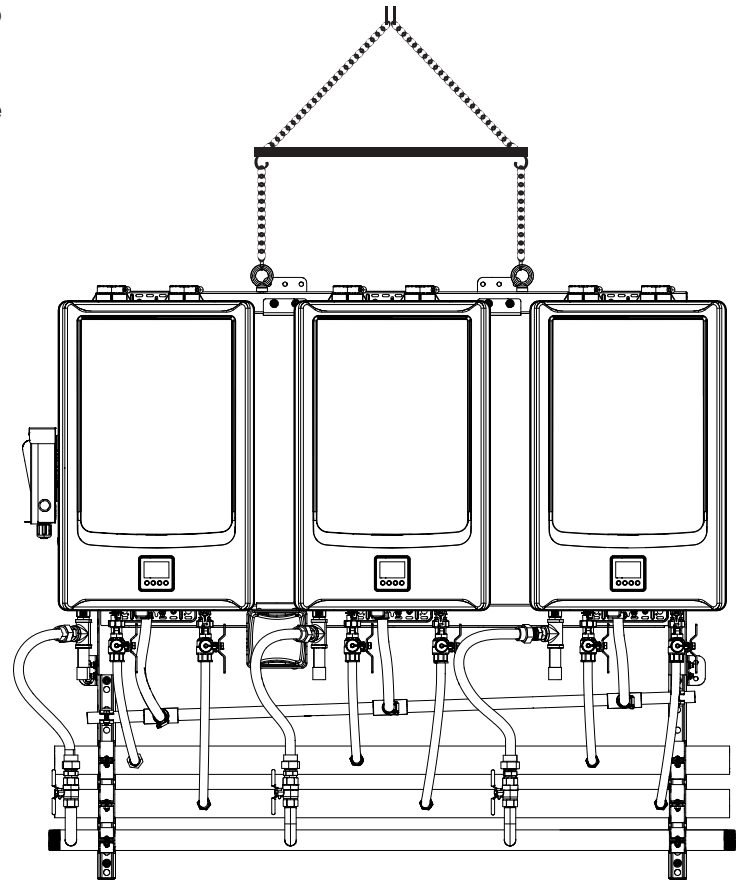
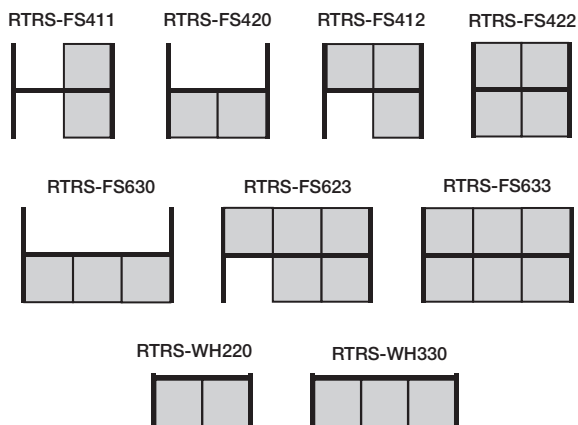

Hoisting Straps - Optional

Use hoisting straps looped around the top frame. Weights of the complete assemblies are available in the Specifications section of this manual.

NOTE:

DO NOT hoist the crate or palette.

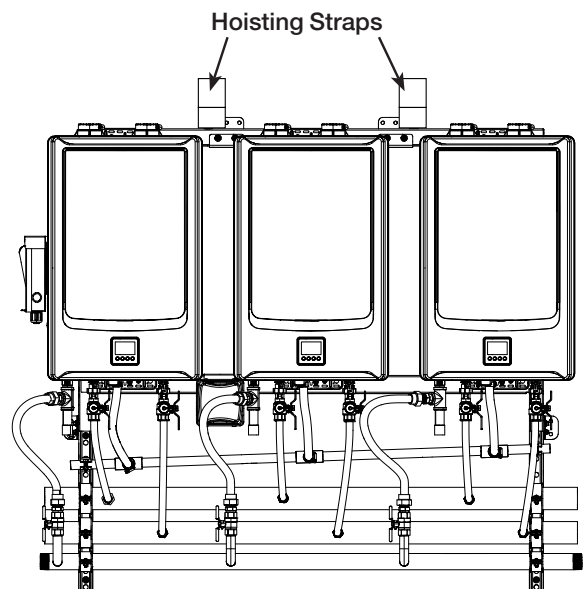

SECURING THE RACKS

Securing Free Standing Racks

All mechanical components shall be anchored and installed in accordance with national and/or local codes having jurisdiction. Base holes to secure all free standing RTRS are 0.563 inches in diameter. Reference local codes regarding minimum concrete thickness and use appropriate expansion anchors

that is capable of supporting the RTRS operating weight or where installation is outdoor, anchors should be capable supporting the RTRS weight and wind shear. Reference and follow anchor manufacturer's use and installation requirements.

Free Standing Models Available

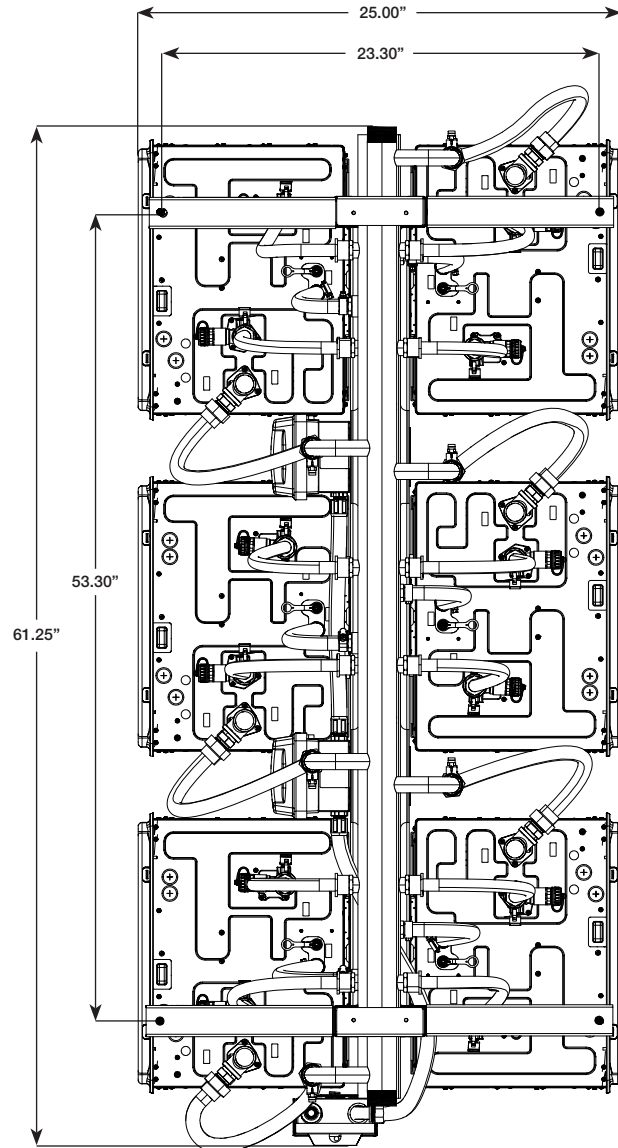
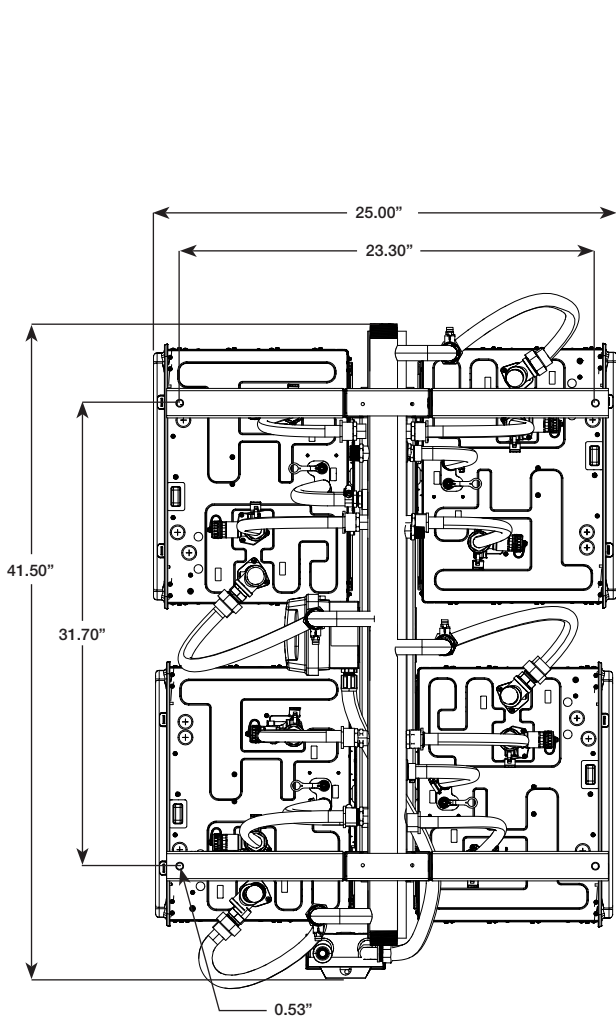
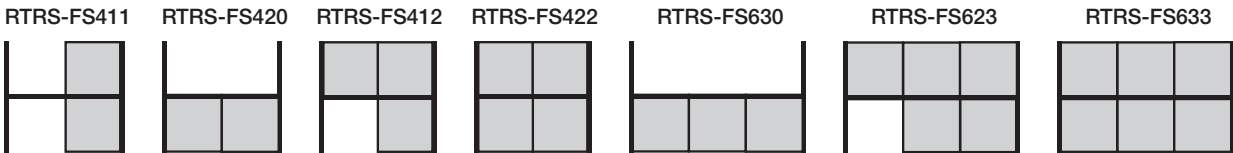

SECURING THE RACKS

Securing Wall Hung Racks

⚠WARNING:

The wall must be capable of carrying the operating weight of the installed RTRS System. Consult a structural engineer for structural analysis of the wall and appropriate hanging methods before attempting to hang the RTRS System. Failure to comply with the above requirement could result in substantial property damage, severe personal injury or death.

- Identify the installation location and confirm that the installation will meet all required clearances.
- In the event of a conflict or inconsistency between items indicated in this manual regarding code requirements, the more stringent standard shall prevail.

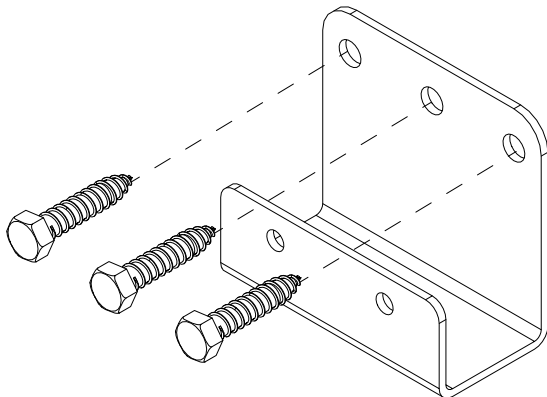

1. Using the holes in the wall hanging bracket, securely attach the bracket level to the wall. Ensure that the attachment strength is sufficient.

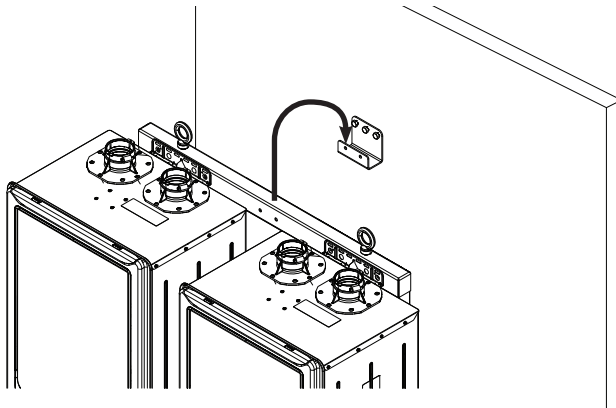

2. Lift the wall hanging rack, and insert the top of the frame into the bracket.

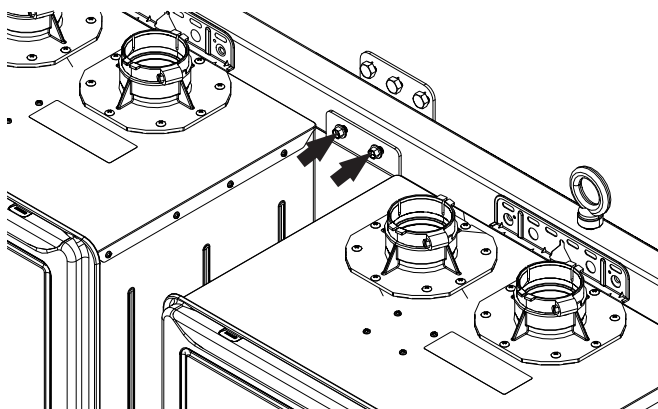

3. Secure the front of the bracket to the front of the wall hanging frame with a #12 x 3/4 drill point screw.

VENTING OPTIONS

Venting Options	Exhaust Vent Material	Intake Vent Material	Max. Vent Length			
			Number of water heaters	3" Common Vent	4" Common Vent	6" Common Vent
Common Venting System	PP & PVC	PP & PVC	2	60' (18.3 m)	150' (45.7 m)	170' (51.8 m)
			3	40' (12.2 m)	150' (45.7 m)	170' (51.8 m)
			4	30' (9.1 m)	70' (21.3 m)	170' (51.8 m)
			5	25' (7.6 m)	45' (13.7 m)	170' (51.8 m)
			6	N/A	35' (10.7 m)	170' (51.8 m)
			7	N/A	30' (9.1 m)	170' (51.8 m)
			8	N/A	25' (7.6 m)	170' (51.8 m)
			9	N/A	N/A	95' (29 m)
			10	N/A	N/A	95' (29 m)
			11	N/A	N/A	50' (15.2 m)
			12	N/A	N/A	50' (15.2 m)

- Refer to the high efficiency commercial condensing tankless water heater use and care manual and common vent installation guide for specific details regarding vent installation option and installation.
- Venting components are packaged and shipped separately from the pre-assembled Rack for field assembly of the vent system by the contractor.



Outdoor Rack Systems include outdoor vent box on each of the water heaters. Please peel off the clear protective film from all of the external surfaces of each outdoor box.

⚠ CAUTION:

2 front openings and their surrounding areas can be hot while the water heater is operating. **DO NOT** touch these areas. **DO NOT** block these openings.

RELIEF VALVE PIPING

Each Rheem tankless water heater on the RTRS comes installed with Isolation valves and a pressure relief valve. Refer to the installation and operation manual for more information on proper piping for the relief valve drain.

Cold Side

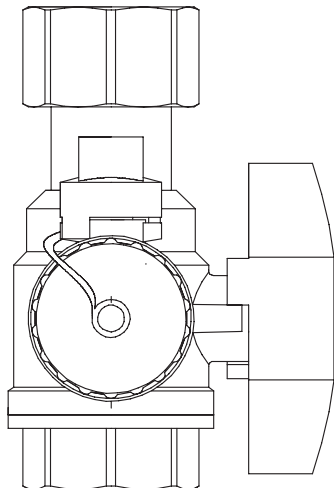

Hot Side

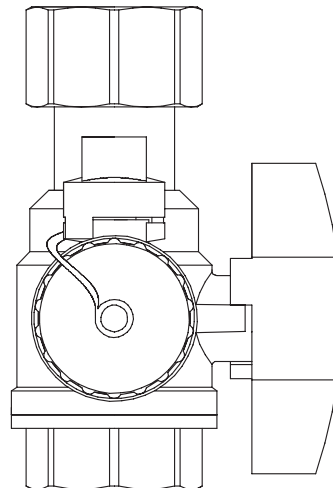

PIPING FOR MULTIPLE RACKS

Multiple rack systems should be installed in parallel using a secondary manifold from the building cold and hot water supply. Reference the drawing on the following page for guidance on plumbing multiple racks in a parallel piping system.

A low pressure gas regulator must be installed prior to the rack system. Note the maximum cumulative input for the system when sizing the gas regulator.

Use common plumbing practice and reference all applicable codes when sizing the secondary manifolds and gas regulator.

END CAPS / CONNECTIONS

End caps are to be field supplied and to be of the following materials:

- Cold water cap - Brass or Copper
- Hot water cap - Brass or Copper
- Gas cap - black iron

Once flow direction and gas supply side is determined the other (opposite) side of the manifold must be capped. See the example below.

Leak check the capped ends of the pipes.

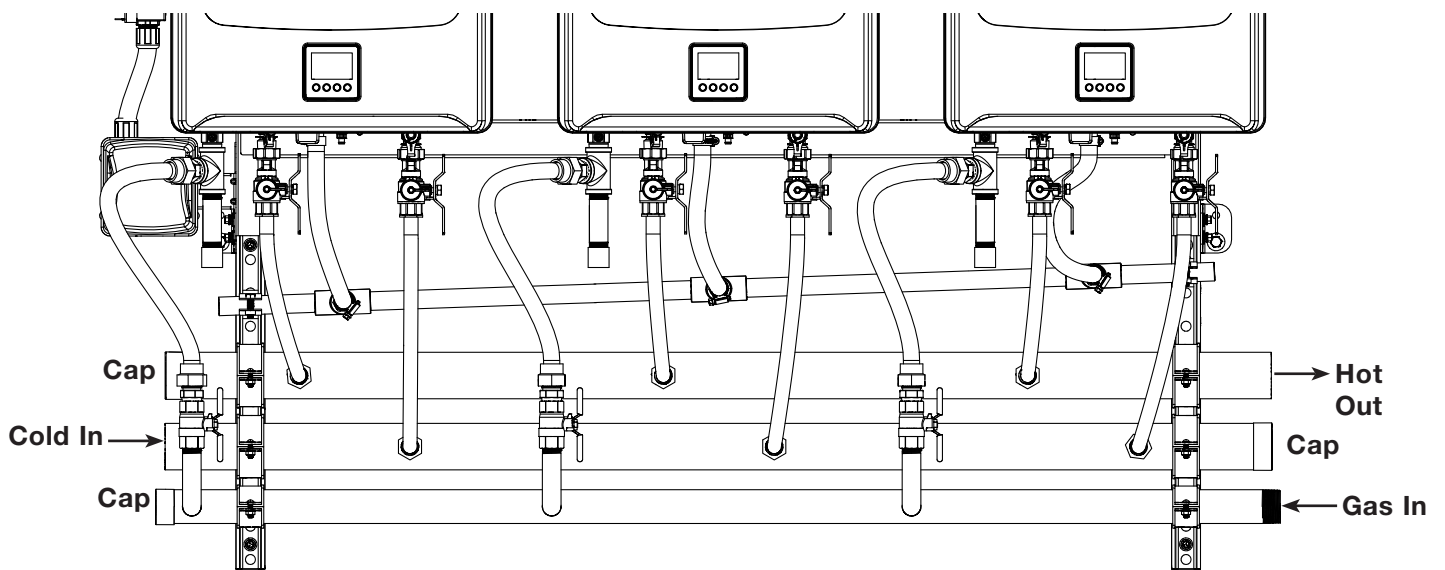

CONDENSATE DRAIN

Each Rheem tankless water heater has a condensate drain outlet on the bottom of the unit. A drain line must be connected to each water heater.

All rack systems will include a prefabricated condensate manifold (not shown in diagram).

Condensate piping shall be CPVC or PVC material and shall not be smaller than the drain connection on the appliance.

Components of the condensate drainage shall be of CPVC or PVC material. All components shall be selected for the pressure and temperature rating of the installation.

Where the drain pipes from more than one unit are manifolded together for condensate drainage, the pipe or tubing shall be sized in accordance with an approved method as dictated by local codes.

Condensate must be disposed of according to local codes.

Piping Diagram for Basic Installation

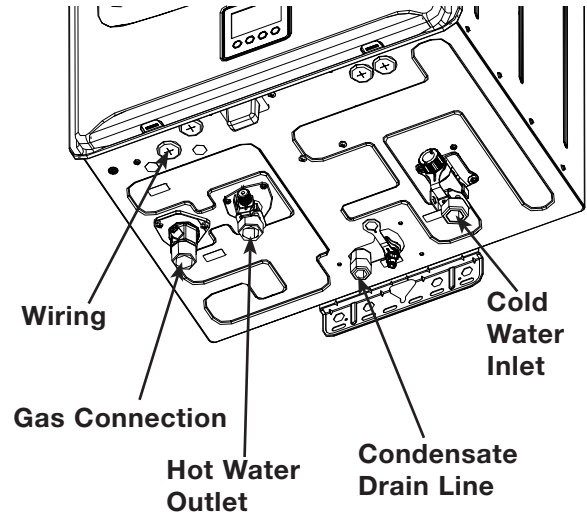

The condensate drain pipe (along its entire length) must be at least the same diameter as the drain line.

CONDENSATE MANIFOLD

Condensate Manifolds are installed above the water manifolds.

Condensate drain must be sloped downward at 2 degrees from the rack system. Condensate must be disposed of per local codes.

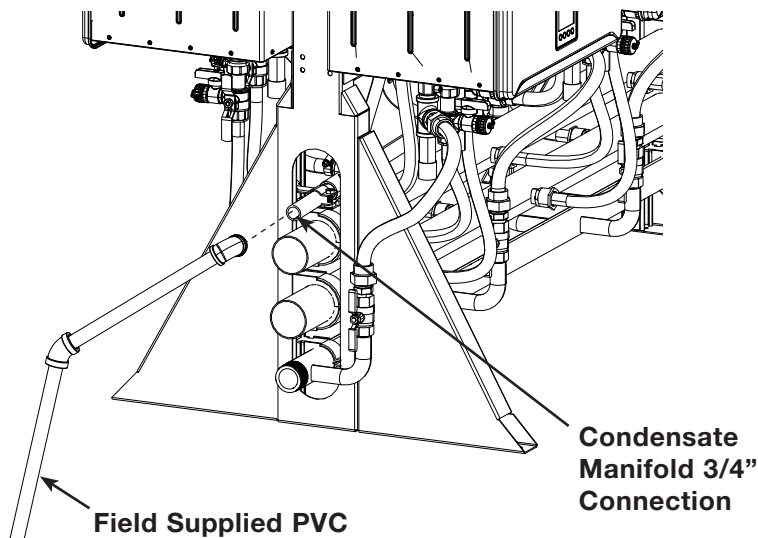

CHECKLIST FOR PLUMBING

- Purge the water line of all debris and air by closing the hot water isolation valve and opening the cold water isolation valve and its drain. Debris will damage the water heater. Use a bucket or hose if necessary.
- Ensure that hot and cold water lines are not crossed to the unit and are leak free.
- Ensure that a pressure relief valve is installed with a rating that exceeds the BTU input of the water heater model. Refer to the rating plate on the side of the water heater for BTU input.
- Clean the inlet water filter by closing the cold and hot water inlet isolation valves. Put a bucket under the filter at the bottom of the water heater to catch any water that is contained inside the unit. Unscrew the water filter. Rinse the filter to remove any debris. Install the filter and open the isolation valves.
- Check for proper water pressure to the water heater. Minimum water pressure is 50 psi. Rheem recommends 60-80 psi for maximum performance.
- Ensure any issues regarding water quality have been properly addressed.

INSTALLATION OF GAS SUPPLY

▲WARNING:

A licensed professional must install the gas supply.

1. Turn off 120v power supply.
2. Turn off the gas.
3. Gas is flammable. **DO NOT** smoke or provide other ignition sources while working with gas.
4. **DO NOT** turn on the water heater or gas until all fumes are gone.

Safety Check

- Check the type of gas and the gas inlet pressure before connecting the water heater. If the water heater is not of the gas type that the building is supplied with, **DO NOT** connect the water heater. Contact the dealer for the proper unit to match the gas type.
- Check the gas supply pressure immediately upstream at a location provided by the gas company. Supplied gas pressure must be within the limits shown in the Specifications section of this manual with all gas appliances operating.
- Before placing the appliance in operation, all joints including the heater must be checked for gas tightness by means of leak detector solution, soap and water, or an equivalent nonflammable solution, as applicable. (Since some leak test solutions, including soap and water, may cause corrosion or stress cracking, the piping shall be rinsed with water after testing, unless it has been determined that the leak test solution is noncorrosive.)

- Use approved connectors to connect the unit to the gas line. Purge the gas line of any debris before connection to the water heater.
- Any compound used on the threaded joint of the gas piping shall be a type that resists the action of liquefied petroleum gas (propane/ LPG).
- The gas supply line shall be gas tight, sized, and so installed as to provide a supply of gas sufficient to meet the maximum demand of the heater and all other gas consuming appliances at the location without loss of pressure.

Information

- If in doubt about the size of the gas line, refer to an approved pipe sizing chart

ELECTRICAL CONNECTIONS

⚠ WARNING:

DO NOT use an extension cord or an adapter plug with this appliance.

The water heater must be electrically grounded in accordance with local codes and ordinances or, in the absence of local codes, in accordance with the National Electrical Code, ANSI/NFPA 70.

Indoor water heaters are equipped with a three-prong (grounding) plug for your protection against shock hazard and should be plugged directly into a properly grounded three-prong receptacle. **DO NOT** cut or remove the grounding terminal from this plug.

DO NOT rely on the gas or water piping to ground the water heater. A screw is provided in the junction box for the grounding connection.

The water heater requires 120 VAC, 60 Hz power from a properly grounded circuit.

If using the 5 foot long power cord, plug it into a standard 3 prong 120 VAC / 60 Hz properly grounded wall outlet. On outdoor models, a disconnect switch must be provided and installed for the incoming 120 VAC power. It should be a type that is suitable for outdoor use. Check the National Electrical Code, ANSI/NFPA 70 and your local codes for a proper switch type to use in your area.

The wiring diagram is located on the Technical Sheet attached to the inside of the front cover of the water heater.

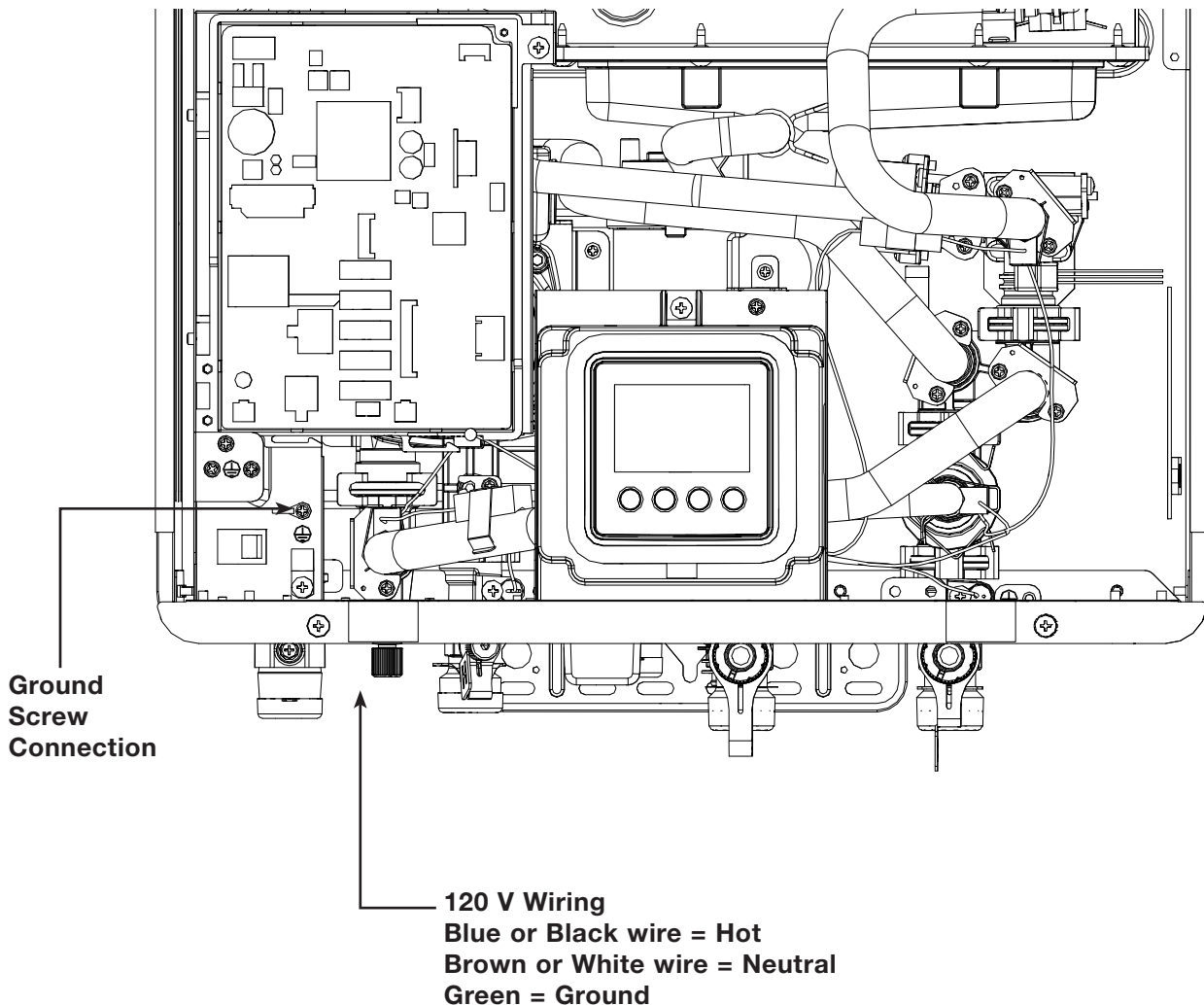

ELECTRICAL INDOOR (PRE-WIRED ELECTRIC ASSEMBLY)

Electrical Assemblies are installed on the middle rack frame of the following racks for single point electrical connection.

IMPORTANT:

Refer to the Specifications sections in this manual for electrical requirements.

Interior Models Available With Pre-Wired Electrical Assemblies:

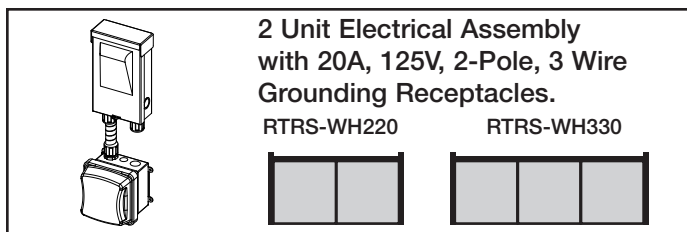

2 Unit Electrical Assembly with 20A, 125V, 2-Pole, 3 Wire Grounding Receptacles.

RTRS-WH220 RTRS-WH330

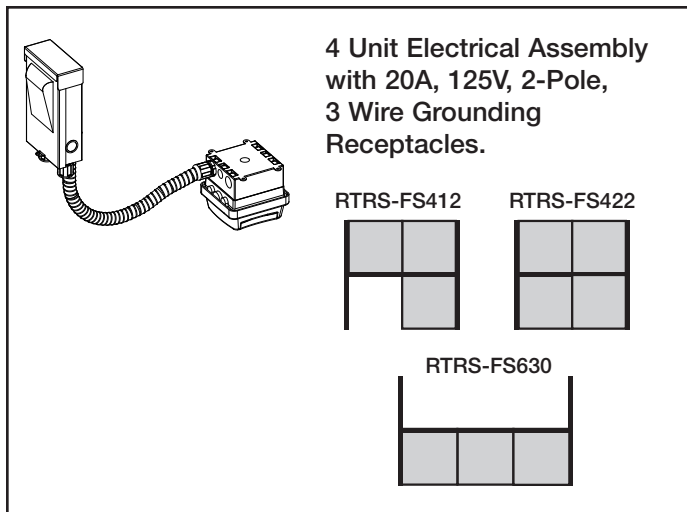

4 Unit Electrical Assembly with 20A, 125V, 2-Pole, 3 Wire Grounding Receptacles.

RTRS-FS412 RTRS-FS422

RTRS-FS630

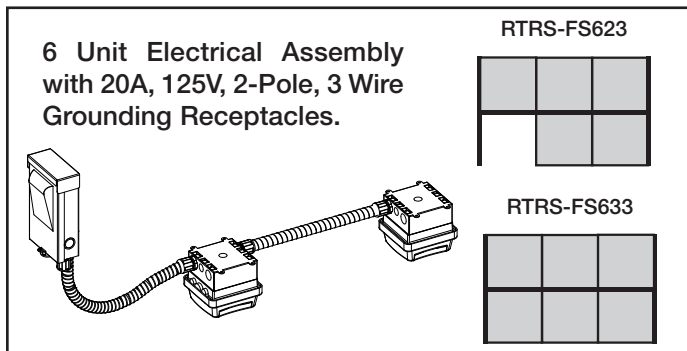

6 Unit Electrical Assembly with 20A, 125V, 2-Pole, 3 Wire Grounding Receptacles.

RTRS-FS623

RTRS-FS633

⚠️ WARNING ⚡:

Shut off building supply power prior to connecting to RTRS electrical assembly. Failure to do so may result in property damage, bodily harm, or death.

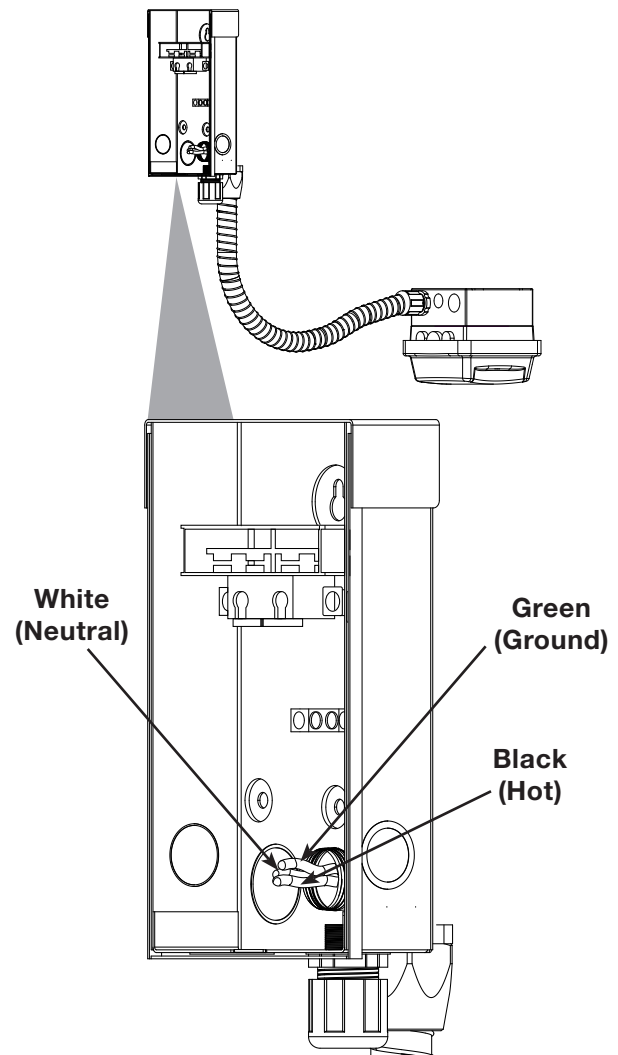

⚠️ CAUTION :

DO NOT connect the tankless water heaters to the outlet located under the center rack prior to connecting building power supply to the rack electrical gang box. Doing so may cause damage to the PC Boards of the tankless water heaters.

1. Locate gang box on side of RTRS frame.
2. Remove the 2 screws securing front panel to gang box.
3. Remove front panel.
4. Run building supplied electrical wiring and conduit to gang box.
5. Connect building wiring to the 3 12AWG, THHN wires, Hot (Black), Neutral (White), and Ground (Green).
6. Reinstall front panel to gang box using 2 screws.

ELECTRICAL INDOOR (PRE-WIRED ELECTRIC ASSEMBLY)

7. Once the building electrical power supply has been wired to the rack system, plug the indoor units into the outlet located under the center rack frame as shown below.

IMPORTANT:

The outlet is designed for use with Rheem Tankless Water Heaters only. **DO NOT** insert power cords belonging to other appliances or electrical sources into the outlet.

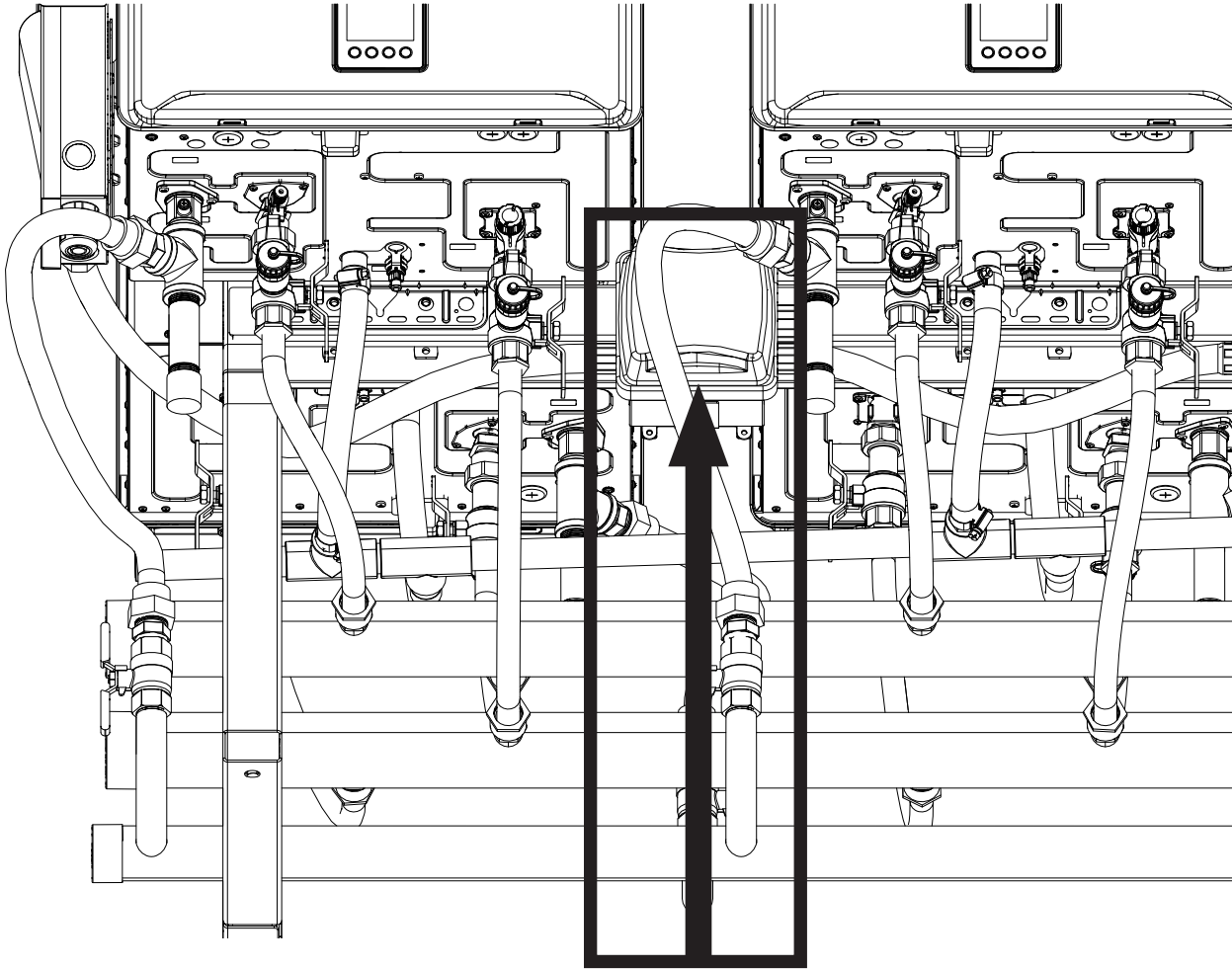

Electrical Box is designed for use by
Rheem Tankless Water Heaters only

ELECTRICAL OUTDOOR (PRE-WIRED ELECTRIC ASSEMBLY)

IMPORTANT:

Refer to the Specifications sections in this manual for electrical requirements.

Outdoor Models Available With Pre-Wired Electrical Assemblies:

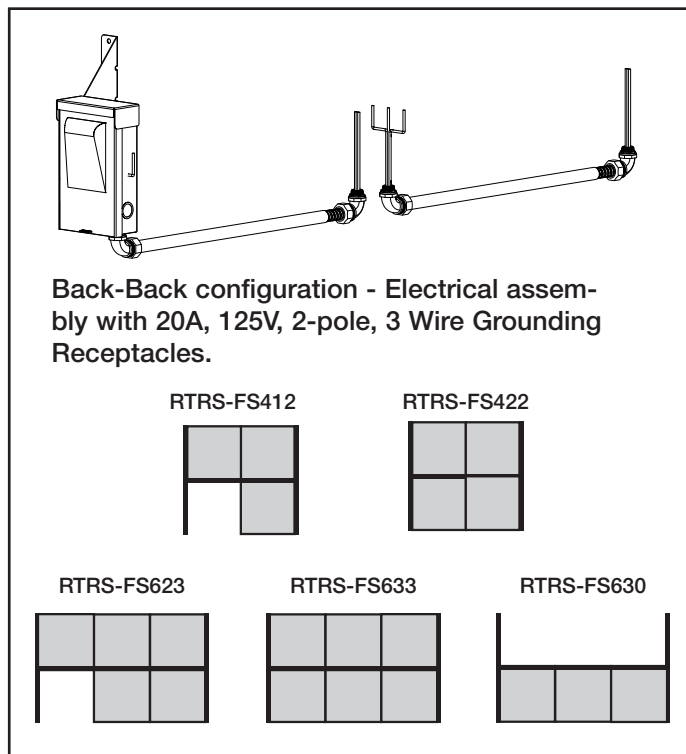
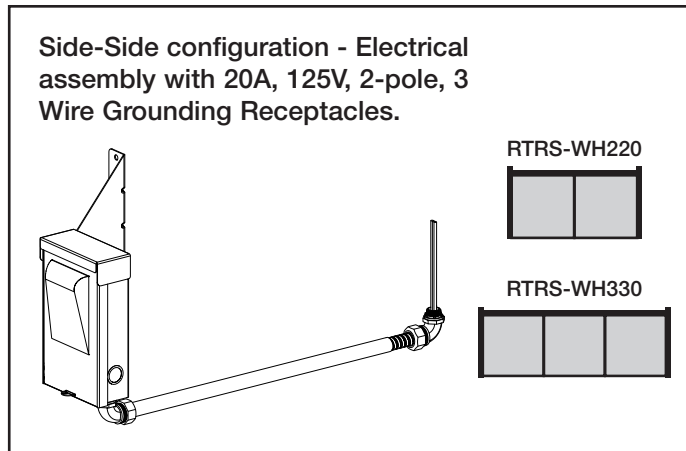

⚠️ WARNING:

Shut off building supply power prior to connecting to RTRS electrical assembly. Failure to do so may result in property damage, bodily harm, or death.

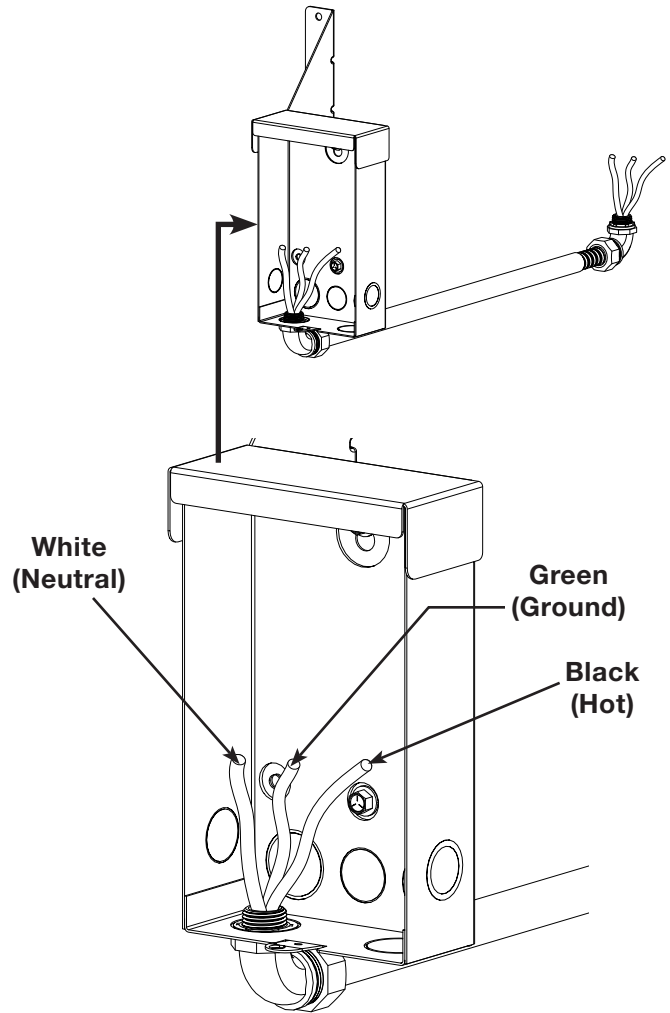

⚠️ CAUTION:

DO NOT connect the tankless water heaters to the outlet located under the center rack prior to connecting building power supply to the rack electrical gang box. Doing so may cause damage to the PC Boards of the tankless water heaters.

1. Locate gang box on side of RTRS frame.
2. Remove the 2 screws securing front panel to gang box.
3. Remove front panel.
4. Run building supplied electrical wiring and conduit to gang box.
5. Connect building wiring to the 3 12AWG, THHN wires, Hot (Black), Neutral (White), and Ground (Green).
6. Reinstall front panel to gang box using 2 screws.

ELECTRICAL OUTDOOR

(PRE-WIRED ELECTRIC ASSEMBLY)

7. Once the building electrical power supply has been wired to the rack system, the system is powered and ready to run. Outdoor racks are pre-wired in factory.

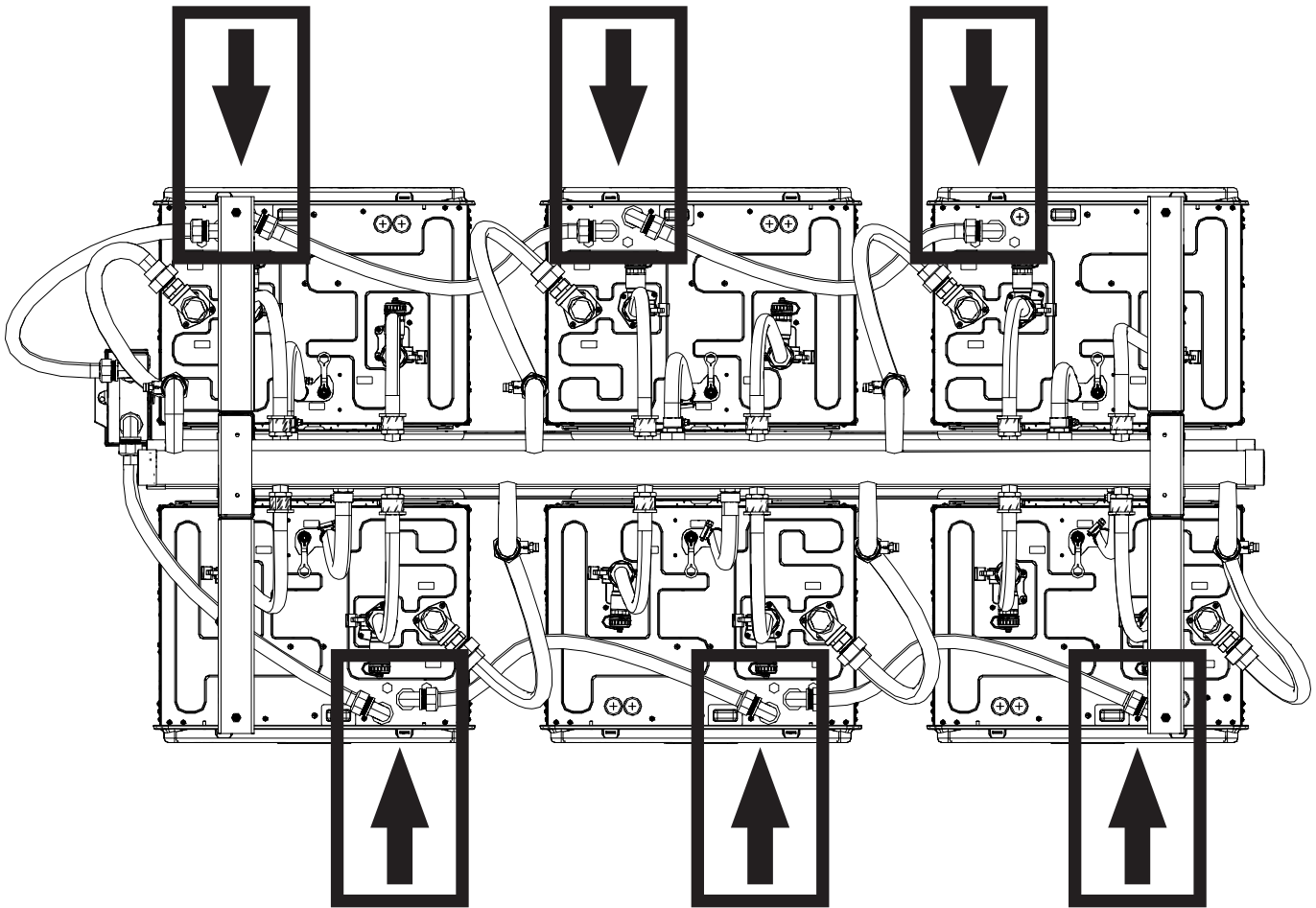

Outdoor Electrical Wiring Connections

MULTIPLE UNITS CONTROLS

The rack system arrive pre-programmed with RJ25 cables installed from factory. The following instruction is only needed if installer wishes to change or reset manifolding operation.

For installation of multiple water heaters, ensure proper manifolding of the controls and common venting as outlined in the section below. Note that up to 32 water heaters can be manifolded, however, gas lines, water lines, and vent pipes can only be common vented for a maximum of 12 water heaters. 3" vent headers should only be used on 2 heater installations. Please refer to the Common Vent Installation Instructions for details on more than 2 heater set-ups. For manifold systems with built-in recirculation pump, the first water heater in the series must contain the built-in recirculation pump to ensure proper operation. Additional water heaters in the series can be recirculation or non-recirculation based on application requirements.

This water heater includes multiple unit controls to manifold up to 32 water heaters together. To accomplish multiple unit controls, a RJ25 communication cable(s) is required. Contact a store where tankless water heaters were purchased to purchase the RJ25 communication cable(s).

Suggested RJ25 Communication Cables	
Part Number	Length
RCPN-AMP03-0013111101-003	48"
RCPN-AMP03-0013111101-002	72"
RCPN-AMP03-0013111101-004	240"

1. Turn off water and gas.

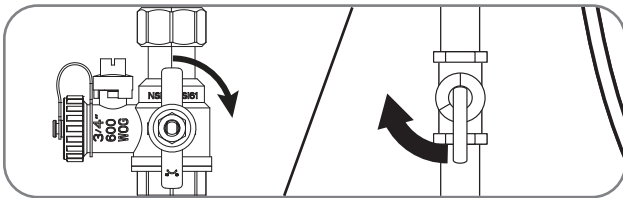

2. Remove 4 screws, and a front cover for all water heaters.

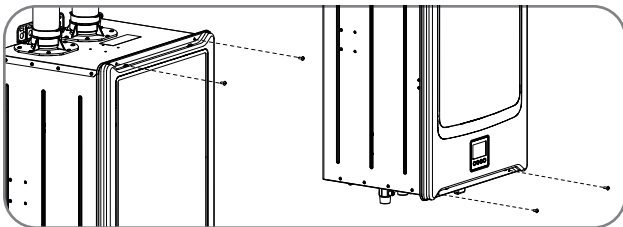

3. Connect all water heaters by the RJ25 Communication Cable(s). The RJ25 Communication Cable(s) should go through a rubber grommet on the bottom of the water heater, and be attached to one of the connectors on the right side of the display. The other end should be attached to another water heater.

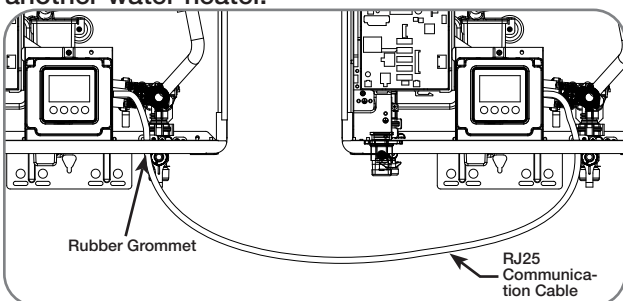

4. Go to a display on one of the units, and press "SETTINGS".

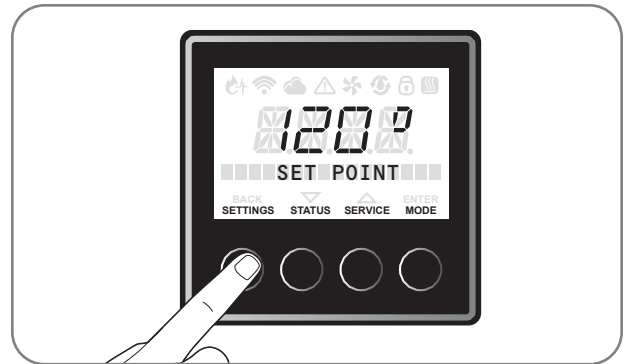

5. Press the "▼" or "▲" button until "NETWORK INSTANCE" is displayed, and press "ENTER" to confirm.

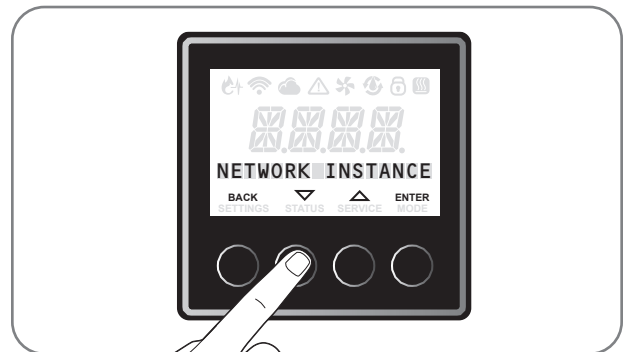

6. Press the "▼" or "▲" button for several times to assign a unique and sequential instance number to the unit, and press "ENTER" to confirm. Repeat steps 4 through 6 until all manifolded units are assigned to a unique instance number.

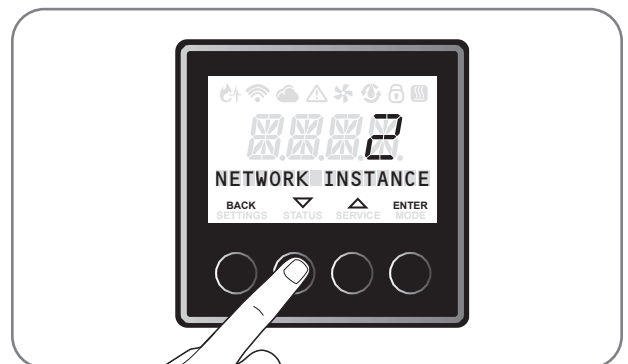

MULTIPLE UNITS CONTROLS

7. Go to the unit display with “INSTANCE” = 1, and press “SETTINGS”.

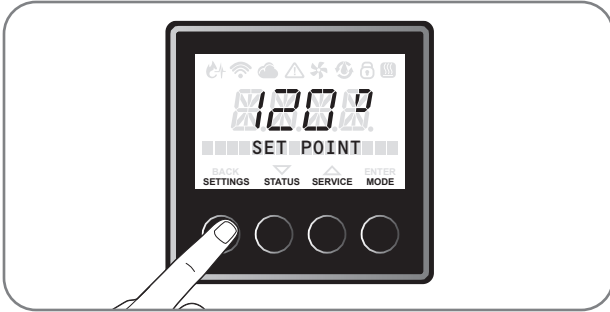

8. Press the “▼” or “▲” button until “Tankless Config” is displayed, and press “ENTER” to confirm.

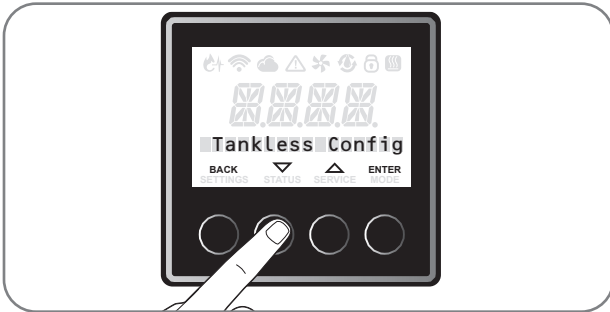

9. Press the “▼” or “▲” button until “Manifold Heaters” is displayed, and press “ENTER” to confirm.

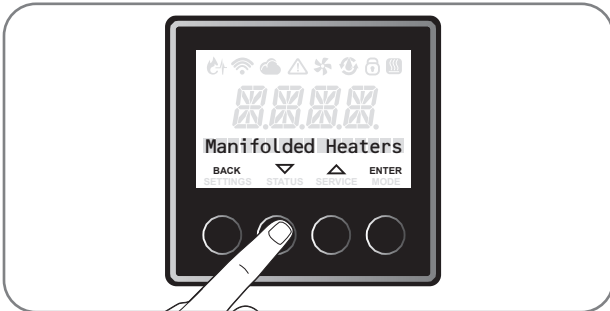

10. Press the “▼” or “▲” button to set the number of manifolded water heaters, and click “ENTER” to confirm.

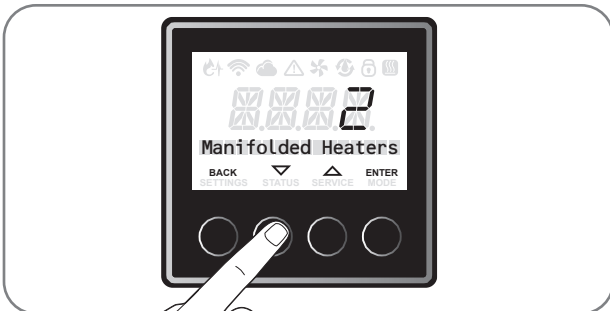

11. Confirm the label “STARTER” is visible on the display of unit instance 2. If more than two units are being linked together, instances 3 and higher will be labeled as “MANIFOLD #*”. The * should correspond to its instance number. These labels may take up to 30 seconds to appear. If set up is not completed properly and you don’t see the text, repeat steps 3 through 10.



12. Instance 1 will have the label “MANAGER” displayed on the main screen. Only Instance 1 is used to control the set point of all the manifolded units.



13. Install the front cover 4 screws to all water heaters.

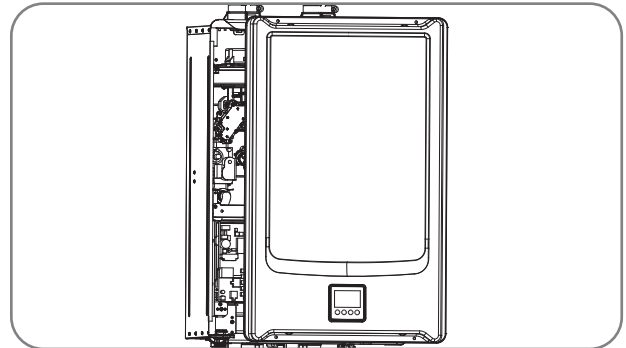

14. Turn on water and gas.



FINAL CHECKLIST

- The water heater is not subject to corrosive compounds in the air.
- The water supply does not contain chemicals or exceed total hardness that will damage the heat exchanger.
- Clearances from the water heater unit are met.
- Clearances from the vent termination and air intake are met. Refer to water heater's U&C manual.
- For indoor models, ensure you have used the correct venting products for the model installed and that you have completely followed the venting manufacturer's installation instructions and these installation instructions.
- For indoor models, verify that the vent system does not exceed the maximum length for the number of elbows used.
- Purge the water line of all debris and air by closing the hot water isolation valve and opening the cold water isolation valve and its drain. Debris will damage the water heater. Use a bucket or hose if necessary.
- Ensure that hot and cold water lines are not crossed to the unit and are leak free.
- A manual gas control valve has been placed in the gas line to the water heater.
- Ensure that a pressure relief valve is installed with a rating that exceeds the BTU input of the water heater model. Refer to the rating plate on the side of the water heater for BTU input.
- Clean the inlet water filter by closing the cold and hot water inlet isolation valves. Put a bucket under the filter at the bottom of the water heater to catch any water that is contained inside the unit. Unscrew the water filter. Rinse the filter to remove any debris. Install the filter and open the isolation valves.
- Check the gas lines and connections for leaks.
- Confirm that the gas inlet pressure is within limits. Refer to water heater's U&C manual.
- Confirm that the water heater is rated for the gas type supplied.
- Confirm that the electricity is supplied from a 120 VAC, 60 Hz power source, is in a properly grounded circuit, and turned on.
- Verify the temperature controller is functioning properly.
- Verify that DIP Switch adjustments are set correctly for your altitude.
- Verify the system is functioning correctly by connecting your manometer to the gas pressure test port on the water heater. Operate all gas appliances in the home or facility at high fire. The inlet gas pressure at the water heater must not drop below that listed on the rating plate.
- DO NOT introduce toxic chemicals such as those used for boiler water treatment to the potable water used for space heating. Refer to water heater's U&C manual.
- If the water heater is not needed for immediate use, then drain the water from the heat exchanger.
- Install the front panel.
- Explain to the customer the importance of not blocking the vent termination or air intake.
- Explain to the customer the operation of the water heater, safety guidelines, maintenance, and warranty.
- The installation must conform with local codes or, in the absence of local codes, with the National Fuel Gas Code, ANSI Z223. 1/NFPA 54, or the Natural Gas and Propane Installation Code, CSA 8149.1. If installed in a manufactured home, the installation must conform with the Manufactured Home Construction and Safety Standard, Title 24 CFR, Part 3280 and/or CAN/SCA Z240 MH Series, Mobile Homes.
- Inform the consumer if the isolation valves are not installed or if a water softening system is not installed.
- Leave the entire manual taped to the water heater (indoor models), temperature controller (outdoor models), or give the entire manual directly to the consumer.

Pre-operating Checklist

- Is the main gas valve to the water heater open?
- Is the fuse in place or is the breaker turned on?
- Does the water heater's electronic ignition light?
- Is the water temperature set to a safe temperature?
- Is the water heater connected to a floor drain?
- Is the water heater properly vented to the outside?
- Is the water heater installed in a safe location away from flammable materials and/or freezing conditions?

REPLACEMENT PARTS

RTRS Replacement Parts Reference Numbers

All RTRS-WH

Ref. #	Description
1	Gas Flex Line Assembly
2	Gas Shut-Off Valve
3	Hot Water Flex Line
4	Cold Water Flex Line
5	Cold Isolation Valve
6	Hot Isolation Valve

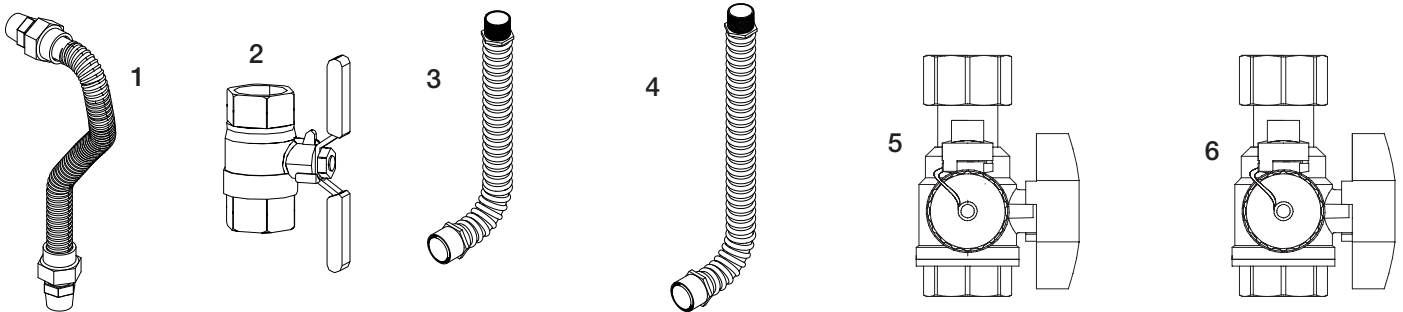
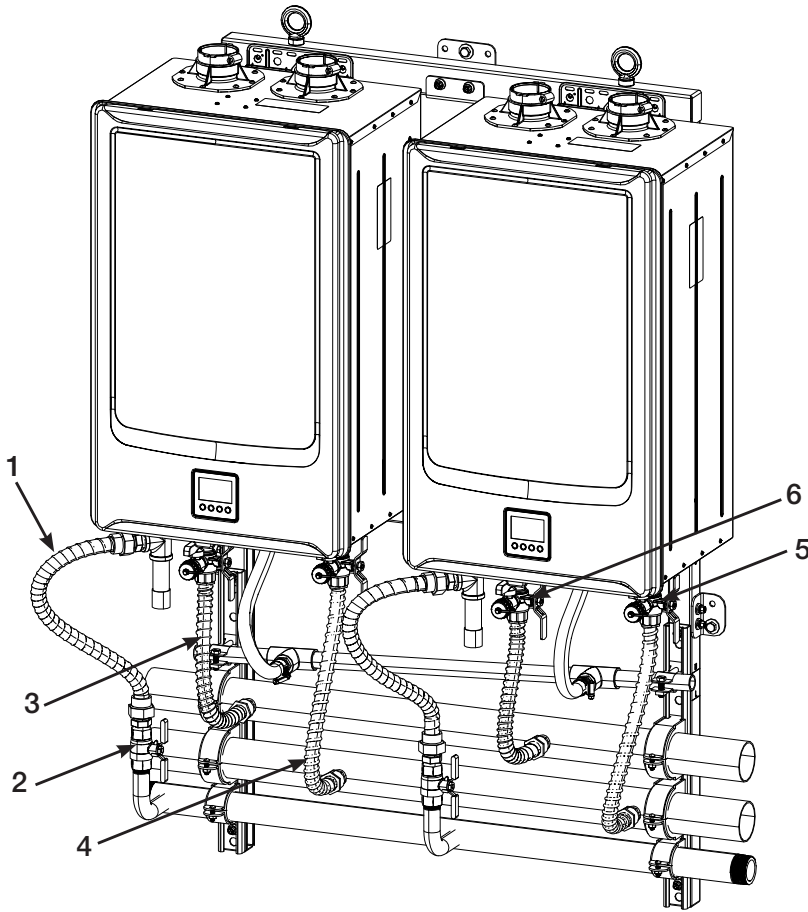

REPLACEMENT PARTS

RTRS Replacement Parts Reference Numbers

ALL RTRS-FS

Ref. #	Description
1	Gas Flex Line Assembly
2	Gas Shut-Off Valve
3	Hot Water Flex Line
4	Cold Water Flex Line
5	Cold Isolation Valve
6	Hot Isolation Valve

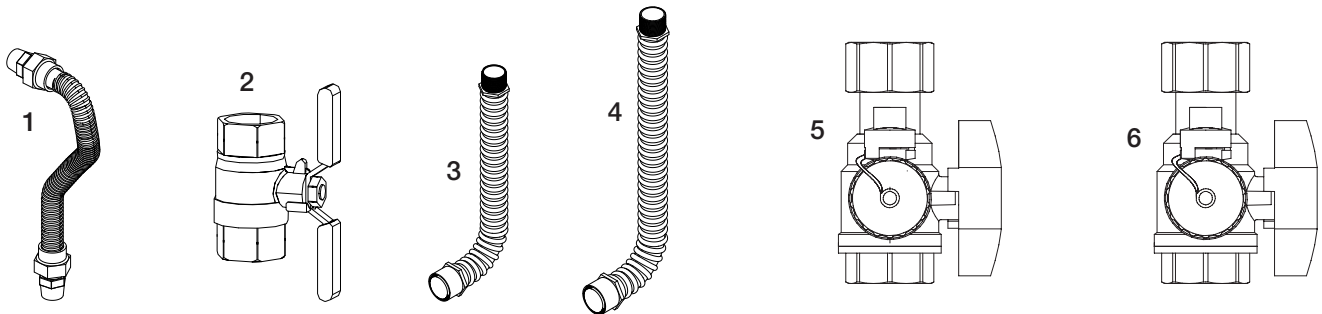
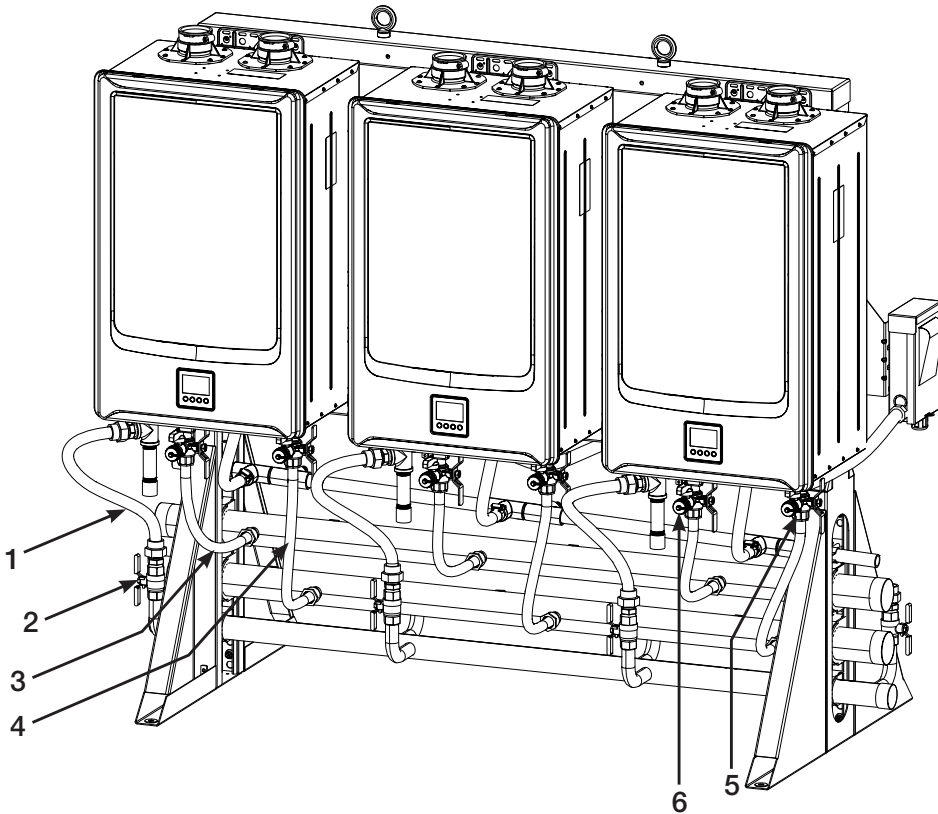

IMPORTANT SAFETY INFORMATION

RTRS Replacement Parts Reference Numbers

Outdoor Models Electrical Assemblies

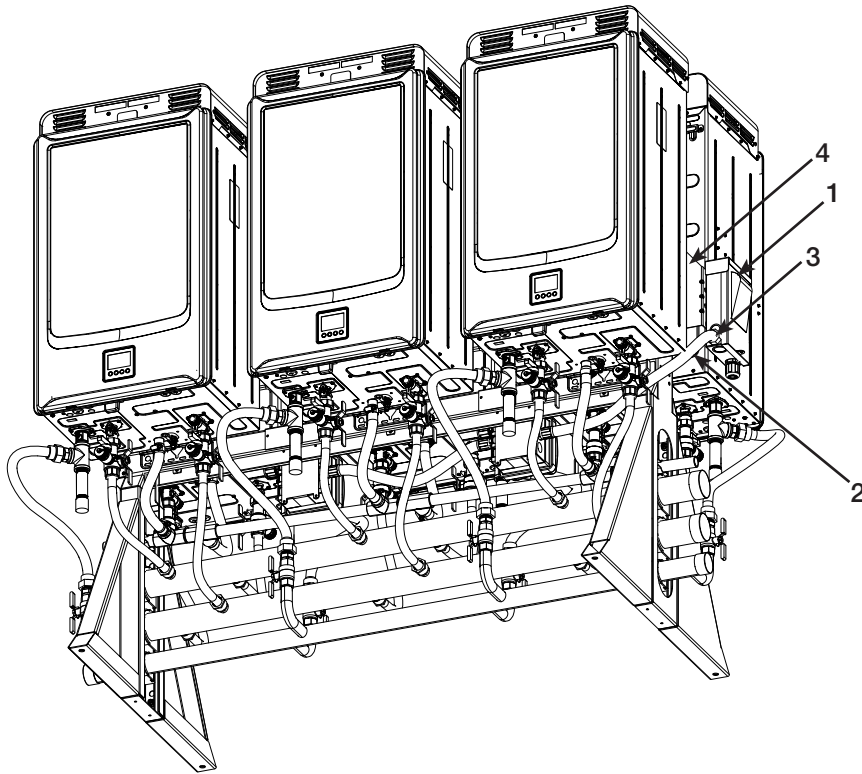

Ref.#	Description
1	Electrical Connections
2	Flexible Conduit

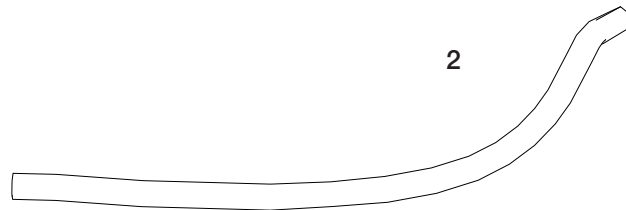
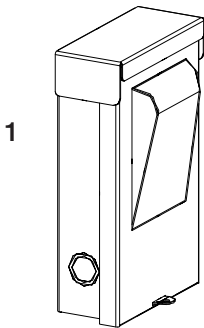

IF YOU NEED SERVICE



Call for Assistance

1. All questions, adjustments, repairs, and/or routine maintenance should be directed to your installer, plumbing contractor, or licensed service agent. If your contacts have moved or are not available, please refer to the telephone directory, commercial listings, or local utility company for qualified service assistance.

2. If your problem has not been solved to your satisfaction, contact the Rheem National Service Department at the following address:

Rheem
National Service Department
800 Interstate Park Drive
Suite 700
Montgomery, AL 36109
Phone: 1-866-720-2076

When contacting the manufacturer, the following information will be requested:

- A. Model and serial number. (See page 8 or the ratings plate on the side of the water heater.)
- B. Address where the water heater is located.
- C. Name and address of installation contractors (page 8) and all qualified service companies that have worked on the water heater.
- D. Original installation date. (See page 8.)
- E. Dates any service or preventive maintenance was performed.
- F. Details of the persisting problem.
- G. List of businesses that have tried to fix this problem, along with dates of service.

LIMITED WARRANTY

For the RHEEM® & RUUD® Commercial Tankless Gas Water Heaters.

GENERAL

This Limited Warranty is only available to the original owner of the water heater at the original installation location. This Limited Warranty is not transferable.

Rheem Sales Company, Inc. (Rheem) warrants this tankless gas water heater, and its component parts, to be free from defects in materials and manufacture, under normal use and service, for the Applicable Warranty Period specified below. At its option, Rheem will repair or replace the defective water heater, or defective component part(s), in accordance with the terms of this Limited Warranty, if it fails in normal use and service during the Applicable Warranty Period. The replacement water heater must be manufactured by Rheem under one of the covered brand names. The replacement component part(s) must be Rheem authorized component part(s). The replacement unit will be warranted only for the unexpired portion of the original unit's Applicable Warranty Period.

Rheem strongly recommends that this tankless water heater be installed by a contractor that is licensed, state qualified and trained on Rheem's tankless products because improper installation may invalidate warranty coverage.

EFFECTIVE DATE

The Effective Date of warranty coverage (or the beginning of the Applicable Warranty Periods) is the date of the original installation of the water heater, if properly documented. Otherwise, it is the date of manufacture of the water heater plus ninety (90) days.

APPLICABLE WARRANTY PERIODS: The Applicable Warranty Period depends on the type of installation, as described below:

Commercial: any installation that is not a single family dwelling

Eight (8) years from the Effective Date for the heat exchanger, five (5) years from the Effective Date for the component parts, and one (1) year from the Effective Date for certain labor as described under the heading, LABOR, SHIPPING AND PROCESSING COST. All warranties void after 12,000 hours of operation.

Commercial: with recirculation, controlled loop

Eight (8) years from the Effective Date for the heat exchanger, five (5) years from the Effective Date for the component parts, and one (1) year from the Effective Date for certain labor as described under the heading, LABOR, SHIPPING AND PROCESSING COST. Provided that the recirculation system is an on demand type system or the pump is controlled with a temperature sensor (aquastat) and timer. All warranties void after 12,000 hours of operation.

Chart for Recommended Water Quality Levels

pH	(Total Dissolved Solids) TDS	Free Carbon Dioxide (CO ₂)	Total Hardness	Aluminum	Chlorides	Copper	Iron	Manganese	Zinc
6.5-8.5	Up to 500 mg/L	Up to 15 mg/L	Up to 200 mg/L	0.05 to 0.2 mg/L	Up to 250 mg/L	Up to 1.0 mg/L	Up to 0.3 mg/L	Up to 0.05 mg/L	Up to 5 mg/L

Cited reference: National Secondary Drinking Water Regulations

LIMITED WARRANTY

Commercial: with recirculation, uncontrolled loop

Three (3) years from the Effective Date for the heat exchanger, three (3) years from the Effective Date for the component parts, and one (1) year from the Effective Date for certain labor as described under the heading, LABOR, SHIPPING AND PROCESSING COST, if the water heater is installed in a system in which the water is re-circulated using a continuously operating pump. All warranties void after 12,000 hours of operation.

RACKS AND COMPONENTS

1 Year Parts Warranty applies to the Rack System and Rack Components including gas and water piping, electrical components, and rack structure.

WARRANTY EXCLUSIONS

This Limited Warranty will not cover:

a) Damages, malfunctions or failures resulting from:

1. Installation of the water heater in environments in which water quality levels DO NOT fall within the ranges listed in the table on previous page.
- b) Operating the water heater in a corrosive or contaminated atmosphere, including without limitation damages, malfunctions or failures caused by lime, mineral build-up, or scale.
- c) Service trips to your business to teach you how to install, use, or maintain this water heater or to bring the water heater installation into compliance with local building codes and regulations or manufacturer's installation requirements.
- d) Water heater unit installed for use in: spa or pool heating; a recreational vehicle; a boat or any other watercraft.
- e) Water heater unit installed in any circulating system in which the temperature of the incoming water to the water heater is in excess of 140° F.
- f) Water heater unit that is installed in any installation supplying radiant heat, such as in floor, baseboard, radiators, snow melt or closed loop systems, or any system using glycol or non-potable water.
- g) Damages, malfunctions or failures resulting from failure to install the water heater in accordance with applicable building codes/ordinances or good plumbing and electrical trade practices.
- h) Damages, malfunctions or failures resulting from improper installation or failure to operate and maintain the unit in accordance with the manufacturer's instructions.
- i) Performance problems caused by improper sizing of the water heater or the gas supply line, the venting connection, combustion air openings, electric service voltage, wiring, or fusing.
- j) Damages, malfunctions or failures caused by improper conversion from natural gas to LP gas or LP gas to natural gas fuel source.
- k) Damages, malfunctions or failures caused by operating the water heater with any parts removed or with modified, altered, or unapproved parts installed.
- l) Damages, malfunctions or failures caused by abuse, accident, fire, flood, freeze, lightning, acts of God and the like.
- m) Heat exchanger failures (leaks) caused by operating the water heater in a corrosive or contaminated atmosphere or damages, malfunctions or failures caused by lime, mineral build-up, or scale.
- n) Damages, malfunctions or failures caused by operating the unit at water temperatures exceeding the maximum setting of the operating, or high limit, control.
- o) Heat exchanger failures caused by operating the water heater when it is not supplied with potable water, free to circulate at all times.
- p) Damages, malfunctions or failures caused by subjecting the heat exchanger to pressures, or firing rates, greater than those shown on the rating label.
- q) Damages, malfunctions or failures resulting from the use of any attachment, including any energy saving device, not authorized by Rheem.
- r) Units installed outside the fifty states (and the District of Columbia) of the United States of America and Canada.
- s) Units removed from the original installation location and reinstalled elsewhere.
- t) Units that have had their rating labels altered, tampered with, or removed. A water heater should not be operated if the rating label is removed.

LIMITED WARRANTY

LABOR, SHIPPING, AND PROCESSING COSTS

For one (1) year after the Effective Date, Rheem will cover reasonable labor costs necessary to repair or replace a tankless water heater or component part that Rheem determines to be defective and covered by this Limited Warranty. The warranty service must be performed by a contractor that is licensed, state qualified, and trained to install and service Rheem's tankless water heaters. This Limited Warranty does not cover any labor expenses for general service, inspection, re-installation, permits, removal and disposal of the failed water heater or defective component part(s), or updating the installation to meet manufacture or local code requirements. All such expenses are your responsibility.

Rheem will pay the transportation costs for an "in-warranty" replacement water heater, or "in-warranty" replacement component part(s), to a convenient delivery point (selected by Rheem) near the place the original water heater, or original component part(s), is located: such as a local water heater distributor. You must pay any local freight charges, including the cost of returning the failed water heater, or defective component part(s) to a convenient shipping location (selected by Rheem): such as a local Rheem distributor.

Rheem does not authorize, recommend, or receive any benefit from any claims processing or similar fees charged by others to process warranty claims for any water heater or component part(s). Rheem will not reimburse any party for these, or any other, fees not specifically covered in this Limited Warranty document.

WARRANTY EXCLUSIONS

This Limited Warranty will not cover:

a) Damages, malfunctions or failures resulting from:

1. Installation of the water heater in environments in which water quality levels DO NOT fall within the ranges listed in the table below:

Any claim for warranty assistance must be made promptly. First, determine if your water heater is "in-warranty" (that is, within the Applicable Warranty Period). You can determine your unit's warranty status by adding its Applicable Warranty Period to its date of installation (for replacements, the date of the original failed unit installation). However, if you DO NOT have documentary proof of your water heater's date of installation, your unit's warranty status will be based on its date of manufacture as determined from the serial number. Add the Applicable Warranty Period plus ninety (90) days to the date of manufacture to determine whether the water heater is still covered by this Limited Warranty. You may also determine your unit's warranty status by obtaining the complete model number, complete serial number, and date of installation of your water heater and then accessing the "Warranty Verification" information on Rheem Water Heaters' Internet website (www.rheem.com) or contacting Rheem's Customer Service Team (telephone (800) 621-5622) during normal business hours (in the Central Time Zone) to determine if the Applicable Warranty Period has expired.

If your water heater is "in-warranty", contact the plumber, or mechanical contractor, that installed it for assistance with the warranty repairs, or replacement, required. Rheem Water Heaters' Technical Service personnel are available to assist you (by telephone at (866) 720-2076) in obtaining "in-warranty" service or to answer your questions about the operation or repair of your water heater during normal business hours (in the Central Time Zone). Be prepared to provide the plumber, mechanical contractor, or Rheem Technical Service person you call with the complete model number, the complete serial number, and the date of installation of your water heater in addition to an explanation of your water heater problem.

If an exact replacement is not available, Rheem will provide you with the current model of your water heater, or component part(s), or a replacement unit with comparable operating features. If government regulations or industry certification or similar standards require the replacement water heater, or replacement component part(s), to have features not found in the defective water heater, or the defective component part(s), you will be charged for the difference in price represented by those required features. If you pay the price difference for those required features and/or to upgrade the size and/or other features available on a replacement new water heater, you will also receive a complete new Limited Warranty (with the full Applicable Warranty Period) for the replacement new water heater.

Rheem reserves the right to inspect, or require the return of, the failed water heater or the defective component part(s). Each "in-warranty" failure water heater must be made available to Rheem (with the rating label and all the component parts intact) in exchange for the replacement water heater. Any failed "in-warranty" component part that must be replaced must be made available to Rheem in exchange for the replacement part. Warranty compensation is subject to validation of "in-warranty" coverage by Rheem Warranty Team personnel.

- To obtain warranty compensation for an "in-warranty" water heater failure, you must have documented proof of failure by a licensed plumber or mechanical contractor or Rheem's Technical Service personnel. The licensed plumber or mechanical contractor will then return the failed unit (with the rating label and all component parts intact) to the place of

IMPORTANT SAFETY INFORMATION

original purchase along with the date the water heater failed. You may also be required to provide documentary proof of the failed water heater's date of installation to establish its "in-warranty" status along with documentation showing you are the original owner.

- To receive warranty compensation for an "in-warranty" defective component part, you must provide Rheem with: the defective component part; the complete model number and the complete serial number of the Rheem or Ruud water heater from which the defective component part was removed; and the date the defective component part failed. You may also be required to provide documentary proof of the date of installation of the Rheem or Ruud water heater from which the defective part was removed – or the date of purchase of the part (if it was purchased separately) – to establish the "in-warranty" status of the defective component part. Alternatively, a licensed plumber or mechanical contractor can return the failed part to a Rheem wholesale distributor and obtain a replacement part, if available.
- If Rheem determines that the water heater or component part returned to Rheem is free of defects in material and manufacture and/or that it was damaged by improper installation or other cause not covered by this Limited Warranty, the warranty claim for the product, component part and/or labor maybe denied.

Warranty claim documentation should be mailed promptly to Rheem National Service Department, 800 Interstate Park Drive Suite 700, Montgomery, Alabama 36109, or in Canada, 125 Edgeware Rd. Unit 1, Brampton, ON, Canada L6Y 0P5

EXCLUSIVE WARRANTY – LIMITATION OF LIABILITY

This Limited Warranty is the only Warranty for this unit given by the Water Heater Division of Rheem Manufacturing Company. No one is authorized to make any other warranties on behalf of Rheem. ANY IMPLIED WARRANTIES, INCLUDING MERCHANTABILITY, OR FITNESS FOR A PARTICULAR PURPOSE, SHALL NOT EXTEND BEYOND THE APPLICABLE WARRANTY PERIODS, SPECIFIED PREVIOUSLY. RHEEM'S SOLE LIABILITY, WITH RESPECT TO ANY DEFECT, SHALL BE AS SET FORTH IN THIS LIMITED WARRANTY, AND ANY CLAIMS FOR INCIDENTAL OR CONSEQUENTIAL DAMAGES (INCLUDING DAMAGE FROM WATER LEAKAGE) ARE EXCLUDED. Some states do not allow limitations on how long an implied warranty lasts, or for the exclusion of incidental or consequential damages, so the above limitations or exclusions may not apply to you.

This Limited Warranty gives you specific legal rights, and you may also have other rights, which vary from state to state.

We suggest you immediately complete the information below and retain this Certificate of Limited Warranty in the event warranty service is needed. Reasonable proof of the date of installation of your water heater may be required to establish its "in-warranty" status. Otherwise, the Effective Date of this Limited Warranty will be the date of manufacture of the water heater plus ninety (90) days. **DO NOT RETURN THIS WATER HEATER OR PART TO RHEEM® WITHOUT A RETURN AUTHORIZATION.**

This document is for reference only and does not replace the original warranty document found in the back of the Use and Care manual provided with the tankless water heater.

DO NOT RETURN THIS DOCUMENT TO RHEEM®. KEEP IT WITH YOUR WATER HEATER OR BUSINESS RECORDS.

Name of Owner: _____

Owner's Address: _____

Name of Plumber/
Mechanical Contractor – Installer: _____

Address of Plumber/
Mechanical Contractor – Installer : _____

Telephone Number of Plumber/
Mechanical Contractor – Installer: _____

Date of Water Heater Installation: _____

Model Number of Your Water Heater: _____

Serial Number of Your Water Heater: _____

