



The new degree of comfort.®



Residential Gas  
Professional *Classic Plus*  
Maximus Water Heaters

## Professional *Classic Plus*® Maximus Gas Water Heater offers maximum efficiency & continuous flow

### Efficiency

- Up to .90 UEF reduces operating cost
- ENERGY STAR® rated

### Performance

- Up to 95G first hour rating depending on model
- Recovery: Up to 64 GPH at a 90° F rise, depending on model

### Easy Installation

- Built-in Condensate Neutralizer
- Certified for multiple termination configurations
- Easy front access to connections and components
- Zero clearance on sides and back
- Longest vent runs, installs as PV or PDV with same unit
- 8" Centers on top water connections for easy replacement of standard gas water heaters
- 1/2" NPT gas connection
- 3/4" NPT water inlet and outlet; 3/4" condensate drain connections
- Side water connections for space heating applications
- Temperature and pressure relief valve installed

### Integration

- Easy to use LCD display with integrated diagnostics

### High Altitude Compliant

- Certified to 10,100 ft. above sea level – **High altitude dongle installation required for over 2000 feet**

### Plus...

- Dual anode rods extend tank life
- Enhanced flow brass drain valve for faster draining
- Start-up Verification for better diagnostics, faster installation and easier servicing

### Warranty

- 8-Year limited tank and parts warranty  
See Residential Warranty Certificate for complete information

Units meet or exceed ANSI requirements and have been tested according to D.O.E. procedures. Units meet or exceed the energy efficiency requirements of NAECA, ASHRAE standard 90, ICC Code and all state energy efficiency performance criteria.



## Professional *Classic Plus* Maximus

40 and 50-Gallon Capacities  
50,000 BTU/h  
Natural and LP Gas  
Ultra Low NOx



LEED Points = 2



For more information, please visit  
[Rheem.com/maximus](http://Rheem.com/maximus)

See specifications chart on next page.



INTEGRATED HOME COMFORT

# Professional *Classic Plus*<sup>®</sup> Maximus Specifications

DESCRIPTION				FEATURES						ROUGHING IN DIMENSIONS (SHOWN IN INCHES)													ENERGY INFO.
TYPE	NOMINAL GALLON CAP.	RATED GALLON CAP.	MODEL NUMBER	GAS INPUT IN THOUS. BTU/H		RECOVERY IN G.P.H. 90° F RISE		FIRST HR. RATING (GALLONS)		HEIGHT TO INTAKE A	OVERALL UNIT HEIGHT B	DIAM. C	HT. TO GAS CONN. D	VENT SIZE E	WATER CONN. CENTER F	HT. TO SIDE TAP HOT G	HT. TO SIDE TAP COLD H	HT. TO EXHAUST J	WATER CONN. SIZE	SHIP WT. (LBS)	UNIFORM ENERGY FACTOR (UEF)		
				NAT.	LP	NAT.	LP	NAT.	LP														
Short	40	40	PRO+G40-50U RH HE EC1	50	-	64	-	88	-	54-1/4	54-1/2	21-3/4	50-1/4	2", 3", 4", 2" or 3" Flex	8	38	12	10	3/4	221	0.90		
Short	40	40	PRO+G40-50P RH HE EC1 (H)	-	50	-	64	-	88	54-1/4	54-1/2	21-3/4	50-1/4	2", 3", 4", 2" or 3" Flex	8	38	12	10	3/4	221	0.90		
Tall	50	50	PRO+G50-50U RH HE EC1	50	-	64	-	95	-	64-1/4	65-1/2	21-3/4	61	2", 3", 4", 2" or 3" Flex	8	48	12	10	3/4	247	0.88		
Tall	50	50	PRO+G50-50P RH HE EC1 (H)	-	50	-	64	-	95	64-1/4	65-1/2	21-3/4	61	2", 3", 4", 2" or 3" Flex	8	48	12	10	3/4	247	0.88		

Uniform Energy Factor and rated gallon capacity based on Department of Energy (DOE) requirements.  
 (H) denotes model is available in high-altitude version. High-altitude versions are required for LP installations at 2000-7800 ft. To order a high-altitude model, add H and the end of the base model number.

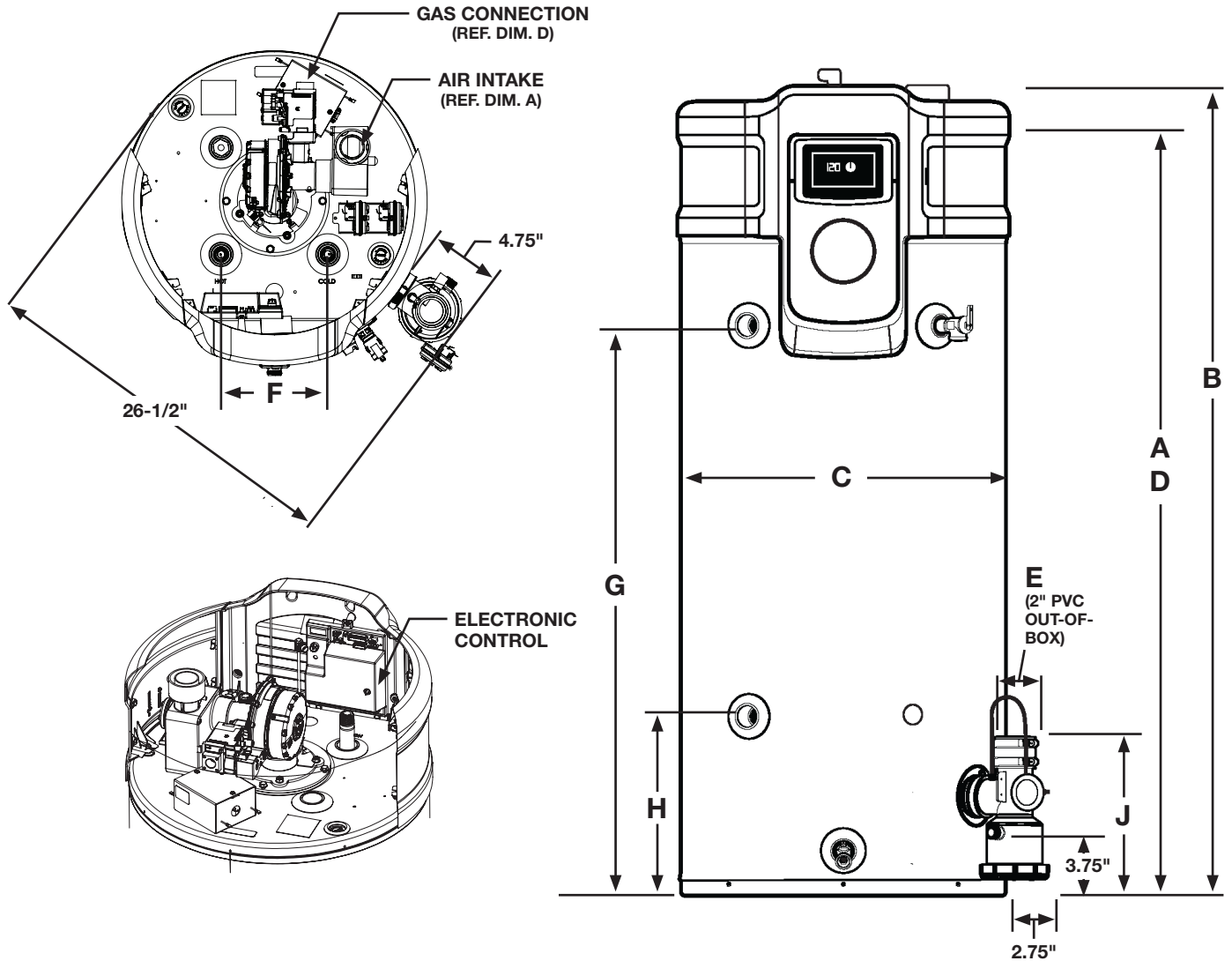

## RESIDENTIAL EQUIVALENT VENT LENGTHS

40G-50K AND 50G-50K; POWER VENT CONFIGURATION; (RIGID PIPE)				40G-50K AND 50G-50K; POWER DIRECT VENT CONFIGURATION; (RIGID PIPE)				TERMINATIONS
ELEVATION (FEET)	VENT SIZE (INCHES)	NAT MAX EQ. LENGTH (FEET)	LP MAX EQ. LENGTH (FEET)**	NAT MAX EQ. LENGTH (FEET)		LP MAX EQ. LENGTH (FEET)**		
				INTAKE	EXHAUST	INTAKE	EXHAUST	
0-2000	2"	50'	50'	50'	50'	50'	50'	2" AND 3" 90° ELBOWS, 2", 3" AND 4" CONCENTRIC AND 2" AND 3" PANCAKE
	3"	140'	140'	140'	140'	140'	140'	
	4"	140'	140'	140'	140'	140'	140'	
2000-5400	2"	50'	40' (High Altitude Model Required)	50'	50'	40'	40'	
	3"	140'	110' (High Altitude Model Required)	140'	140'	110'	110'	
	4"	140'	110' (High Altitude Model Required)	140'	140'	110'	110'	
5400-7800	2"	50'	20' (High Altitude Model Required)	50'	50'	10'	20'	
	3"	140'	110' (High Altitude Model Required)	140'	140'	110'	110'	
	4"	140'	110' (High Altitude Model Required)	140'	140'	110'	110'	
7800-10,100	2"	50'	Not Applicable	50'	50'	Not Applicable	Not Applicable	
	3"	140'	Not Applicable	140'	140'	Not Applicable	Not Applicable	
	4"	140'	Not Applicable	140'	140'	Not Applicable	Not Applicable	
MINIMUM INTAKE AIR AND EXHAUST VENT: 10' EQUIVALENT LENGTH								
NATURAL GAS MODELS CAN BE INSTALLED IN HIGH ALTITUDE LOCATIONS WITH INSTALLATION OF HIGH ALTITUDE DONGLE AS SHOWN IN HIGH ALTITUDE SECTION OF MANUAL.								
**LP GAS MODELS HAVE UNIQUE HIGH ALTITUDE MODEL NUMBERS. THEY ARE FACTORY SET FOR HIGH ALTITUDE OPERATION. HIGH ALTITUDE MODELS HAVE A 'H' DESIGNATION AT THE END OF THE MODEL NUMBER.								

**Note:** Vent pipe size should not be mixed for venting these water heater. Use same diameter pipe for all venting of the unit.

All power direct models can use 2" concentric venting only as listed in the above chart.

2" Concentric vent can only be used with 2" rigid piping.

**DO NOT** mismatch concentric vent terminations with different rigid piping as it may cause the heater to malfunction or cause a lock-out condition unless specifically mentioned.

3" Concentric vent may be used with 3" and 4" venting.

FLEXIBLE POLYPROPYLENE PIPE (FT)				
PIPE SIZE (IN.)	2"		3"	
	INTAKE	EXHAUST	INTAKE	EXHAUST
MAX PV	0	30'	0	30'

VENTING – ELBOW EQUIVALENT VENT LENGTH					
90°			45°		
SHORT SWEEP	STANDARD	LONG SWEEP	SHORT SWEEP	STANDARD	LONG SWEEP
DO NOT USE	7'	5'	DO NOT USE	4.5'	2.5'

• Each 45 degree elbow reduced the equivalent length by 2-1/2 ft.



The new degree of comfort®



Residential Gas  
Professional *Classic Plus*  
Maximus Water Heaters

## Altitude Guide by Model

MODEL	0-2000 FEET	2000-5400 FEET	5400-7800 FEET	7800-10,100 FEET
40G / 50K BTU NG	No Changes Needed – Good Out The Box	Installation of High Altitude Dongle Required		
40G / 50K BTU LP	No Changes Needed – Good Out The Box	Factory Order Model with “-H” Designation – Installation of High Altitude Dongle Required		N/A
50G / 50K BTU NG	No Changes Needed – Good Out The Box	Installation of High Altitude Dongle Required		
50G / 50K BTU LP	No Changes Needed – Good Out The Box	Factory Order Model with “-H” Designation – Installation of High Altitude Dongle Required		N/A

## Maximus Accessories

PART NO.	DESCRIPTION
SP20897	2" CONCENTRIC TERMINATION
SP20245	3" CONCENTRIC TERMINATION
SP20796	4" CONCENTRIC TERMINATION
SP20285	2" FLAT TERMINATION
SP20286	3" FLAT TERMINATION
SP21091	2" POLYPROPYLENE FLEX PIPE – 30 FEET
AP19356	3" POLYPROPYLENE FLEX PIPE – 30 FEET
SP21172	AUTO SHUTOFF VALVE KIT



Flat Vent Termination (SP20285, SP20286)

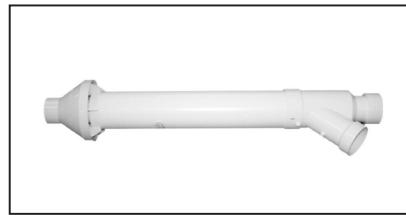

Concentric Vent Termination (SP20897, SP20245, SP20796)

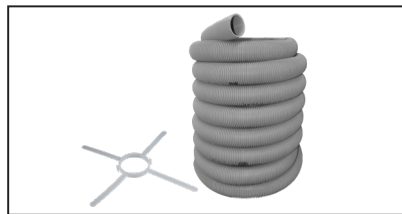

Flex Venting Kit (SP21091, AP19356)

In keeping with its policy of continuous progress and product improvement, Rheem reserves the right to make changes without notice.

Rheem Water Heating • 1115 Northmeadow Parkway, Suite 100  
Roswell, Georgia 30076 • www.rheem.com

Rheem Canada Ltd./Ltée • 125 Edgeware Road, Unit 1  
Brampton, Ontario L6Y 0P5 • www.rheem.ca



INTEGRATED HOME COMFORT