



Boilers

Your Comfort, Perfectly

controlled.

Rheem® FT™ Series Super High Efficiency
Condensing Gas Boilers

*FULL COLOR INTUITIVE
TOUCHSCREEN DISPLAY*



Reliable High Performance Boilers

for Home Heating Needs and Domestic Hot Water with an Indirect Tank

Rheem® FT™ Series Boilers deliver high efficiency performance with up to 96% thermal efficiency, 95% AFUE, a 26,000–110,000 BTU/hr capacity range, and turndown ratios up to 10:1. Featuring scalable cascading, an intuitive touchscreen with 4-zone control, and optional BACnet® integration (select models), they are well suited for residential and light commercial new construction or retrofit applications.

Intuitive Touchscreen Display Controls:

- **Easy Setup & Maintenance:** Simplifies setup, diagnostics, maintenance and troubleshooting
- **4-Zone Control:** Manages up to four heating zones with individual temperature settings, no external controllers needed
- **System Monitoring:** Real-time operational data
- **Color-Coded Alerts:** Quick visual status notifications
- **Historical Error Logs:** Access to data for troubleshooting
- **USB Port:** Enables fast backups and software updates
- **Cascade Capability:** Controls up to 4 boilers (FT110, FT150, FT199) and up to 24 boilers (FT260, FT399)

Maximum Performance:

- **96% thermal efficiency** (FT399) and **95% AFUE** (FT110, FT150, FT199, FT260)
- **ENERGY STAR® Certified**
- **Stainless Steel Fire Tube Heat Exchanger:** ASME rated for safety and quality; efficiently transfers heat from combustion gases to water
- **10:1 Turndown Ratio** (FT260, FT399) and **6.5:1 Turndown Ratio** (FT110, FT150, FT199) increases boiler efficiency and life

Built-In Features:

- **Moisture Free Zone (MFZ) Technology:** Protects components from corrosion
- **Outdoor Reset Control:** Adjusts water temperature with outdoor conditions

- **Reverse Flow Detection:** Detects and alerts if water is flowing in the wrong direction
- **Safety Limits:** With built-in certified **low water cutoff** and **high-limited protection**
- Seamlessly operates with **Rheem indirect tanks** for consistent domestic hot water

Easy to Install & Service:

- **Shared Parts Platform:** Universal touchscreen with two shared components (fan & gas valve) simplifies diagnostics, servicing, and parts inventory
- **Extended Venting Lengths:** Up to 200 ft (2" or 4"), 480 ft (3")
- **Condensate System:** Condensate helps to keep the heat exchanger clean
- **PVC/CPVC/PP** approved venting materials
- Fuel conversion kits included (FT110, FT150, FT199)
- BACnet interface option available (FT260, FT399)

Warranty:

- **15-Year Heat Exchanger, 5-Year Parts, 1-Year Labor**



PROVIDES DOMESTIC HOT WATER



FLEXIBLE INDIRECT TANK SUPPORT

Control at Your Finger Tips

All **Rheem® FT™ Series Boilers** include a full color intuitive touchscreen display featuring the latest in controls technology and software.



HOME SCREEN

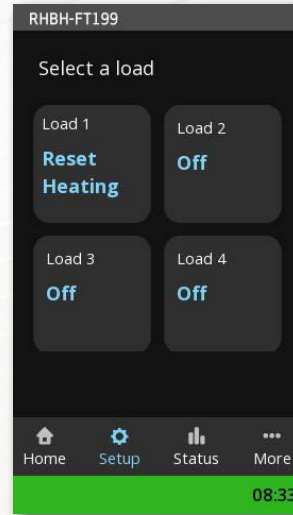

LOAD SETTINGS

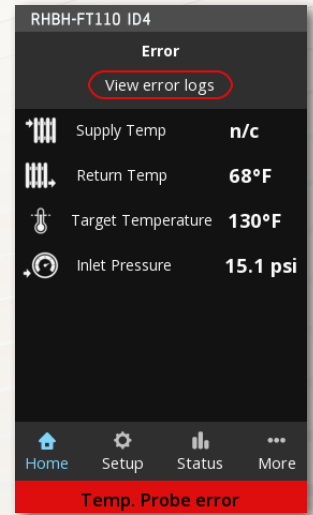

ERROR SCREEN

Moisture Free Zone Technology

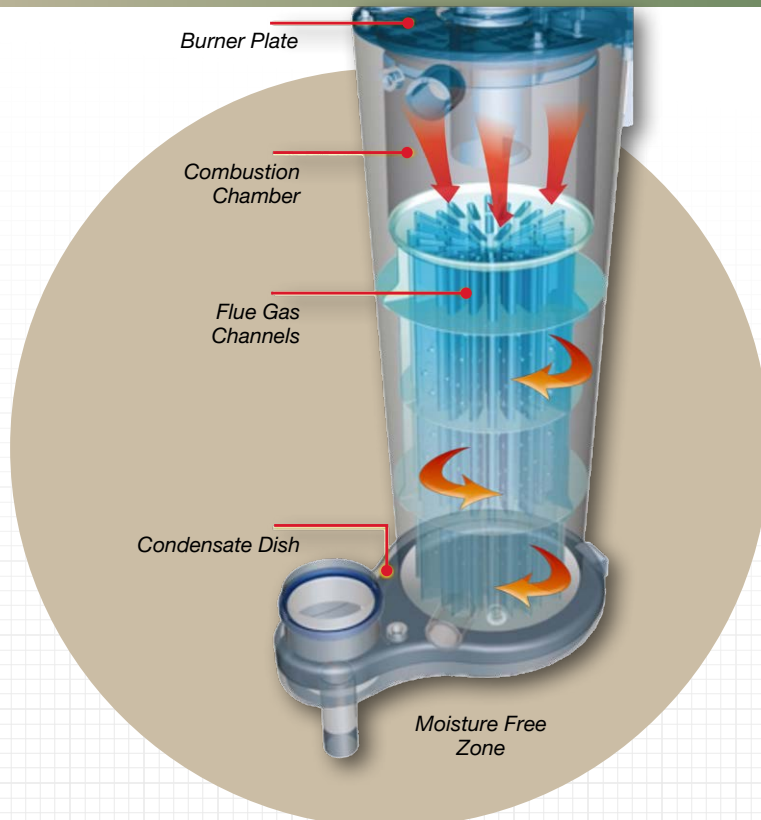

Moisture Free Zone (MFZ) Technology

is Rheem's advanced moisture management system featured on all FT™ Series models. Residual latent heat can shorten the life of combustion components, and condensate inside the heat exchanger can cause premature wear on stainless steel surfaces.

MFZ protects against these issues by purging the heat exchanger of moisture and latent heat at the end of each heating cycle. The result is longer life for both the heat exchanger and critical combustion components.

Interior Components & Key Unique Features

KEY UNIQUE FEATURES

MODEL NO.	RHBH-FT110	RHBH-FT150	RHBH-FT199	RHBH-FT260	RHBH-FT399
95% AFUE	✓	✓	✓	✓	—
96% Thermal Efficiency	—	—	—	—	✓
Turndown Ratio	6.5:1	6.5:1	6.5:1	10:1	10:1
Cascading Capability	up to 4 units	up to 4 units	up to 4 units	up to 24 units	up to 24 units
BTU/hr Capacity Range	110,000 -199,000	110,000 -199,000	110,000 -199,000	26,000 -399,000	26,000 -399,000
Suited for Residential, New Builds & Retrofits	✓	✓	✓	✓	✓
Suited for Light Commercial	—	—	—	✓	✓
BACnet Interface Option Available	—	—	—	✓	✓

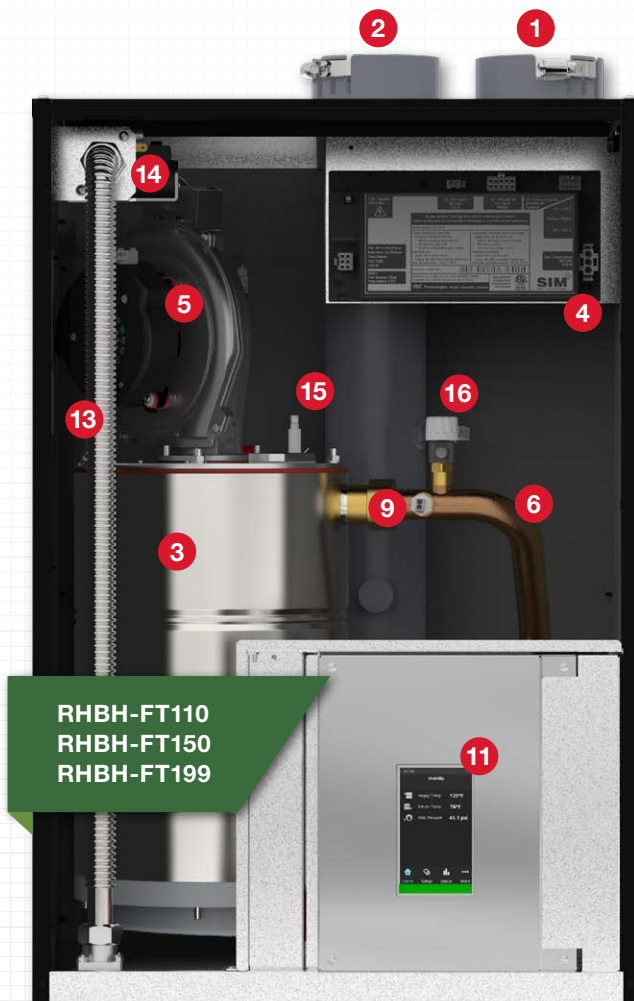

- 1 Intake Duct
- 2 Exhaust Duct
- 3 Stainless Steel Fire Tube Heat Exchanger
- 4 Ignition Module
- 5 Fan
- 6 Supply Pipe
- 7 Return Pipe
- 8 Low Water Cutoff Probe
- 9 Supply Temp. Sensor
- 10 Return Temp. Sensor
- 11 Full Color Intuitive Touchscreen Display
- 12 Water Pressure Sensor
- 13 Gas Line
- 14 Gas Valve
- 15 Ignitor
- 16 Manual Air Vent

Technical Information



EXCELLENT FOR RADIANT FLOOR HEATING

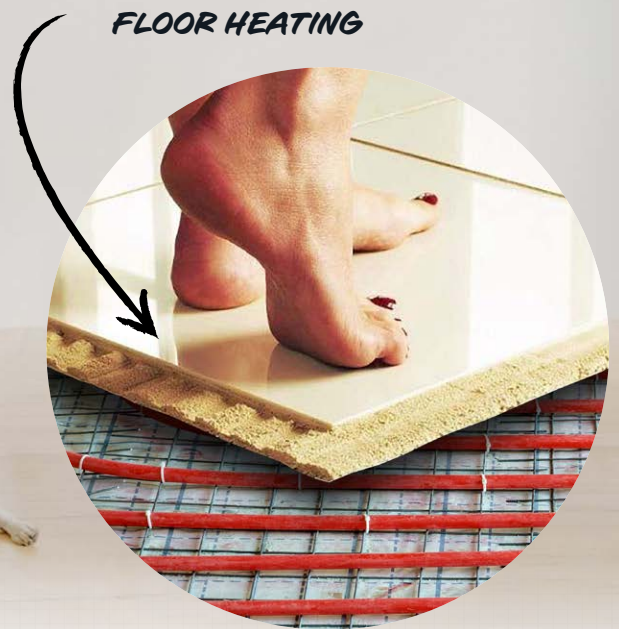

SPECIFICATIONS



MODEL NO.	RHBH-FT110	RHBH-FT150	RHBH-FT199	RHBH-FT260	RHBH-FT399
CSA Input (NG or Propane) – MBH	16.9-110	23-150	30.6-199	26-260	40-399
CSA Input (NG or Propane) – kW	5-32.2	6.7-44	8.8-58.3	7.6-76.2	11.7-117
CSA Output (NG or Propane) – MBH	16.2-101.5	22-138.5	29.2-183.7	24.9-239	38.4-383
CSA Output (NG or Propane) – kW	4.74-29.8	6.5-40.6	8.6-53.8	7.31-70	11.2-112
AFUE* or CE/TE**	95%*	95%*	95%*	95%*	96%**
Min. Gas Supply Pressure (NG or Propane) – inch w.c.	4	4	4	4	4
Max. Gas Supply Pressure (NG or Propane) – inch w.c.	14	14	14	14	14
Ambient Temperature – Low (°F/°C)	32/0	32/0	32/0	32/0	32/0
Ambient Temperature – High (°F/°C)	122/50	122/50	122/50	122/50	122/50
Max. Relative Humidity (Non-Condensing)	90%	90%	90%	90%	90%
Min. Water Temperature (°F/°C)	34/1	34/1	34/1	34/1	34/1
Max. Water Temperature – (Electronic High Limit) (°F/°C)	190/88	190/88	190/88	190/88	190/88
Max. ΔT – Supply/Return (Electronic Fence) (°F/°C)	40/22	40/22	40/22	40/22	40/22
Max. Water Temperature Lockout Limit (°F/°C)	201/94	201/94	201/94	201/94	201/94
Power (120Vac/60Hz) at Full Fire – watts (w/o pumps)	90	79	90	127	190
Weight (Empty) – lbs/kg	67/30.4	78/35.4	88/39.9	162/74	240/110
Pressure Vessel Water Content – USG/Liters	1.88/7.12	2.8/10.56	3.51/13.29	4.64/17.56	6.66/25.21
Max. Boiler Flow Rate – USgpm	14	19	25	25	45
Min. Boiler Flow Rate – USgpm	2	3	4	6	20
Max. Operating Water Pressure – psig	50	50	50	30	80
Min. Operating Water Pressure – psig	8	8	8	8	8
Relief Valve Pressure – psig	30	30	30	30	30
Approved Installation Altitude – ASL	0-12,000'	0-12,000'	0-12,000'	0-12,000'	0-12,000'
Ultra Low NOx	Meets 14 ng/J NOx requirements – SCAQMD Rule 1146.2 compliant				

Dimensions RHBH-FT110, RHBH-FT150 & RHBH-FT199

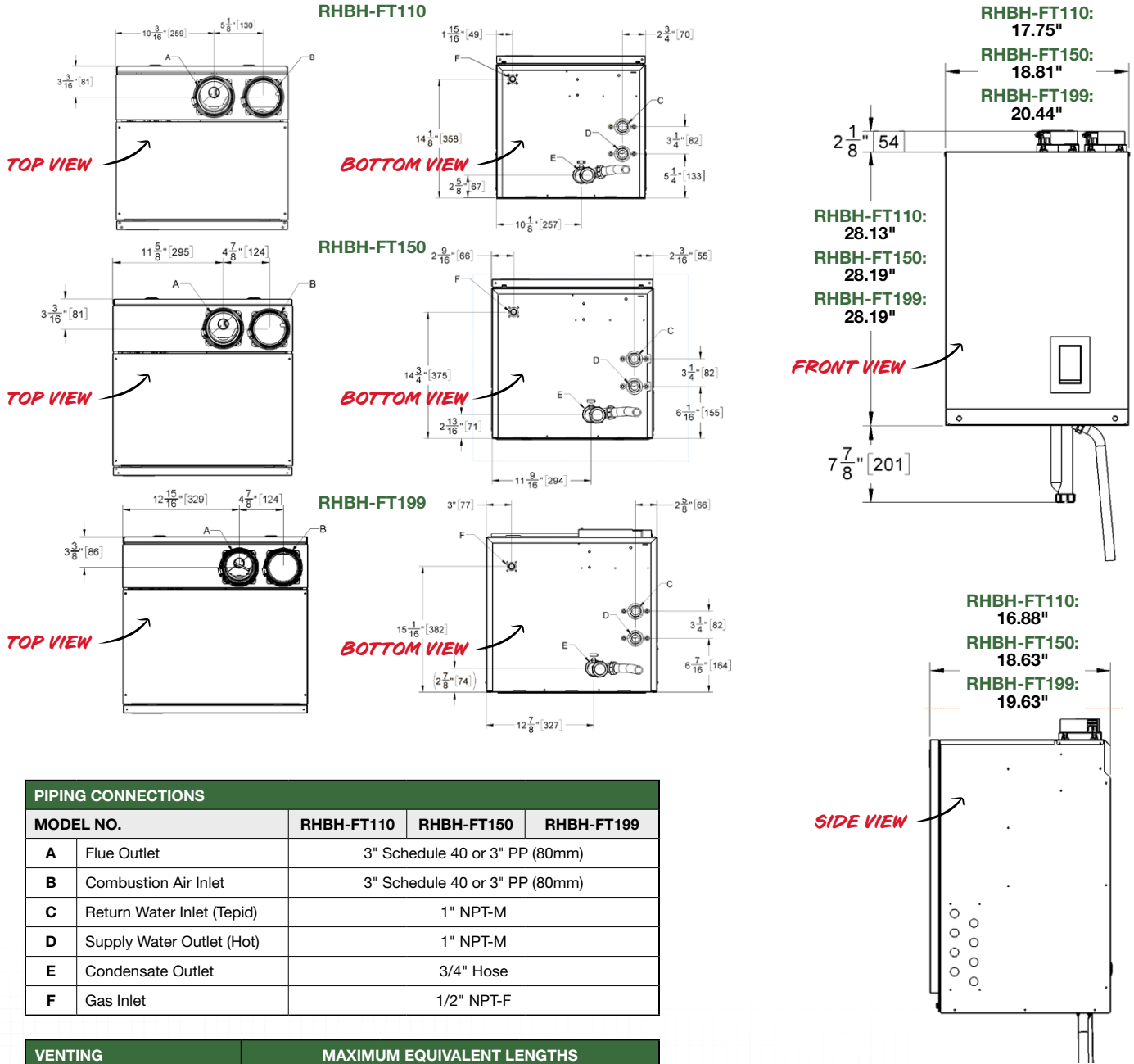

PIPING CONNECTIONS				
MODEL NO.		RHBH-FT110	RHBH-FT150	RHBH-FT199
A	Flue Outlet	3" Schedule 40 or 3" PP (80mm)		
B	Combustion Air Inlet	3" Schedule 40 or 3" PP (80mm)		
C	Return Water Inlet (Tepid)	1" NPT-M		
D	Supply Water Outlet (Hot)	1" NPT-M		
E	Condensate Outlet	3/4" Hose		
F	Gas Inlet	1/2" NPT-F		

VENTING	MAXIMUM EQUIVALENT LENGTHS		
	RHBH-FT110	RHBH-FT150	RHBH-FT199
PVC, CPVC, RIGID PP			
2"	100'	50'	Not Permitted
3"	240'	170'	100'
90° Vent Elbow	Equivalent to 8'		
90° Long Sweep Elbow	Equivalent to 5'		
45° Elbow	Equivalent to 3'		
PP 87-90° Elbows	Equivalent to 8'		
2" Stainless Steel Sidewall Terminal - Exhaust Vent (P-256)	Exhaust: Equivalent to 20' Intake: Equivalent to 0'	Not Permitted	
3" Stainless Steel Sidewall Terminal - Exhaust Vent (P-257)	Exhaust: Equivalent to 20' Intake: Equivalent to 0'		
Flexible PP 3" Flexible	45' (max.) Lineal x 1.2 = Equiv.	45' (max.) Lineal x 2 = Equiv.	30' (max.) Lineal x 3.33 = Equiv.

CLEARANCE FROM BOILER CABINET		
SURFACE	MIN. DISTANCE*	RECOMMENDED DISTANCE**
Front	2"	24"
Rear Flue Connection	0"	0"
Left Side	0"	4" (allow acces to water connections)
Right Side	1"	4" (allow acces to water connections)
Top	2"	6" (for vent connection)
Bottom	0" (clearance for pipes)	12" (for condensate trap and piping)

*From Combustible Surfaces **For Installation & Service

Dimensions RHBH-FT260 & RHBH-FT399

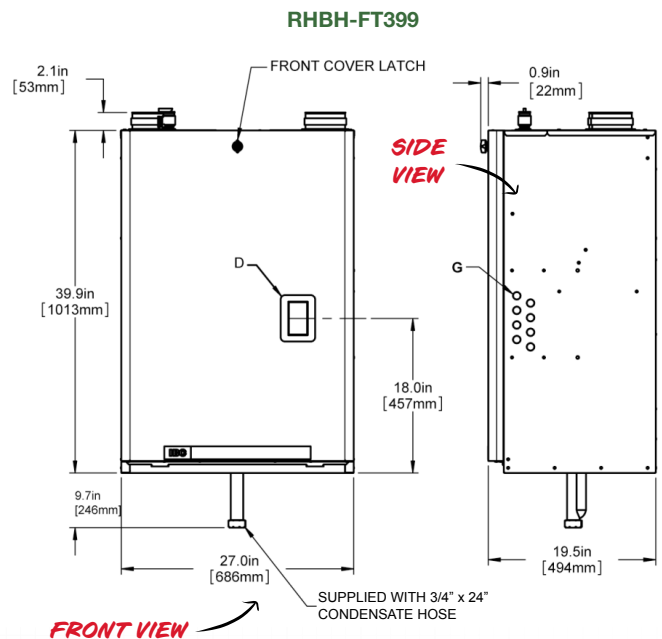
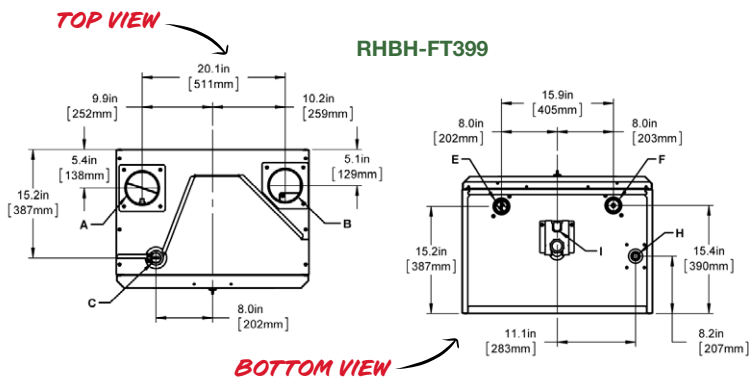
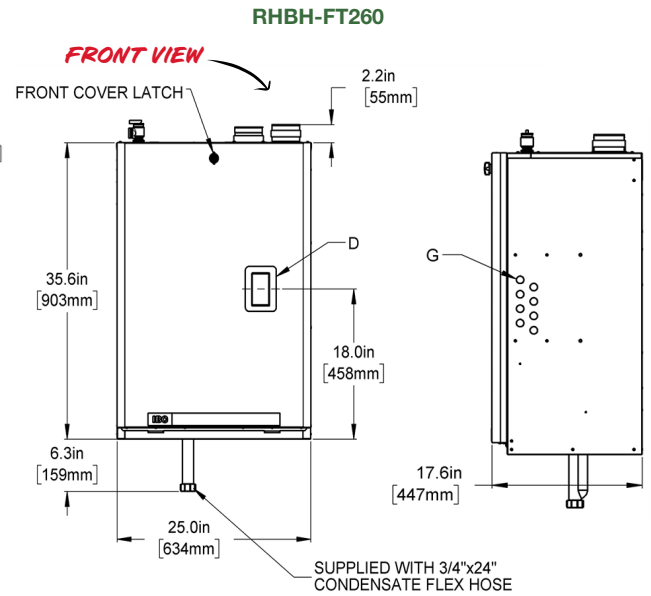
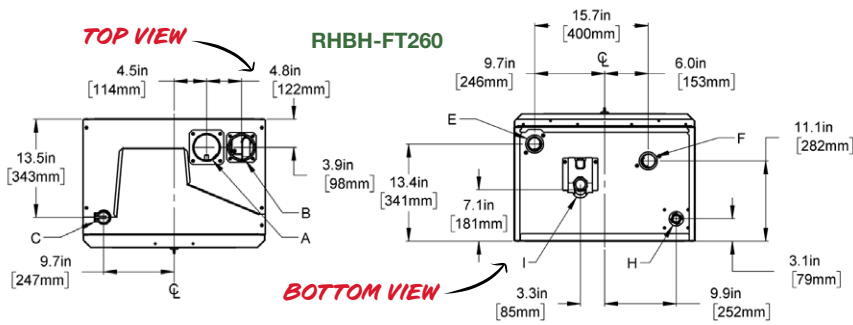

PIPING CONNECTIONS			
MODEL NO.	RHBH-FT260	RHBH-FT399	
A	Flue Outlet	3" Schedule 40	4" Schedule 40
B	Combustion Air Inlet	3" Schedule 40	4" Schedule 40
C	Relief Valve & Air Vent	3/4" NPT-F	
D	Touchscreen Display	2-1/4" x 4"	
E	Supply Water Outlet (Hot)	1-1/2" NPT - M	
F	Return Water Inlet (Tepid)	1-1/2" NPT - M	
G	Knock-Outs (8)	1-1/2"	
H	Gas Inlet	3/4" NPT-F	
I	Condensate Outlet	3/4" Hose	

VENTING		
PVC, CPVC, RIGID PP	RHBH-FT260	RHBH-FT399
3"	200'	—
4"	—	200'
90° Vent Elbow	Equivalent to 8'	
90° Long Sweep Elbow	Equivalent to 5'	
45° Elbow	Equivalent to 3'	
PP 87-90° Elbows	Equivalent to 8'	
3" Stainless Steel Sidewall Terminal - Exhaust Vent (P-257)	Exhaust: Equivalent to 20' Intake: Equivalent to 0'	Exhaust: Equivalent to 65' Intake: Equivalent to 0'
3" CPVC (P-257 adaptor)	—	Allow 3.2' equivalent for each 1'
Flexible PP 3" Flexible	60' (max.) lineal x 3.33 = equiv.	—
Flexible PP 4" Flexible	—	160' max. using 1.2 x for equiv. length

CLEARANCE FROM BOILER CABINET				
SURFACE	RHBH-FT260		RHBH-FT399	
	MIN. DISTANCE*	RECOMMENDED DISTANCE**	MIN. DISTANCE*	RECOMMENDED DISTANCE**
Front	2"	24"	2"	24"
Rear Flue Connection	0"	0"	0"	0"
Left Side	1"	4" (allow access to water connections)	1"	0" (to non-combustibles)
Right Side	1"	4" (allow access to water connections)	1"	4" (for electric and gas if required)
Top	2"	6" (for vent connection)	12"	12" (for vent connection)
Bottom	—	12" (for condensate trap and piping)	—	12" (for condensate trap and piping)

*From Combustible Surfaces **For Installation & Service



Accessories

RHBH-FT110, RHBH-FT150 & RHBH-FT199



P-267 Floor Stand



P-429 Parts Kit



**SCAN TO
LEARN MORE**
or visit Rheem.com/Boilers

RHBH-FT260 & RHBH-FT399



P-266 Floor Stand



Multiplex Racking



Piping Kit



Condensate Tank



P-430 Parts Kit



Air Filter Kit

CONTACT US

**Customer Service,
Warranty and Parts**
800.621.5622

**Technical
Service**
833.212.9276

**Plumber
Support Group**
866.339.2388



Boilers