



Boilers

Rheem® FT™ Series Super High Efficiency Condensing Gas Boilers

Key Features

- Intuitive touchscreen display - controls setup, maintenance and troubleshooting
- 4-Zone control – Manages up to 4 heating zones with individual temperature settings, no external controllers needed
- 96% thermal efficiency (FT399) and 95% AFUE (FT110, FT150, FT199, FT260)
- ENERGY STAR® certified
- Durable design – ASME rated 439 stainless steel fire tube heat exchanger
- Shared Parts Platform – Universal touchscreen with two shared components (fan & gas valve) for streamlined maintenance
- Cascade capability – Controls up to 4 boilers (FT110, FT150, FT199) and up to 24 boilers (FT260, FT399)
- 10:1 turndown ratio (FT260, FT399) and 6.5:1 turndown ratio (FT110, FT150, FT199) for precise heating control
- Extended venting lengths up to 200 ft (2" or 4") and 480 ft (3")
- Flexible venting materials – Compatible with PVC, CPVC, and PP
- Outdoor reset control automatically adjusts water temperature based on outdoor conditions
- Moisture Free Zone (MFZ) technology protects components from corrosion
- Advanced safety features - CSA/UL approved low water cutoff and manual reset high limit
- Reverse flow detection – Detects and alerts if water is flowing in the wrong direction
- Seamlessly operates with Rheem indirect tanks for consistent domestic hot water
- BACnet interface option available (FT260, FT399)

Warranty

- 15-Year Heat Exchanger, 5-Year Parts, 1-Year Labor



**RHBH-FT110, RHBH-FT150
RHBH-FT199, RHBH-FT260
RHBH-FT399**



Specifications

MODEL NO.	RHBH-FT110	RHBH-FT150	RHBH-FT199	RHBH-FT260	RHBH-FT399
CSA Input (NG or Propane) – MBH	16.9-110	23-150	30.6-199	26-260	40-399
CSA Input (NG or Propane) – kW	5-32.2	6.7-44	8.8-58.3	7.6-76.2	11.7-117
CSA Output (NG or Propane) – MBH	16.2-101.5	22-138.5	29.2-183.7	24.9-239	38.4-383
CSA Output (NG or Propane) – kW	4.74-29.8	6.5-40.6	8.6-53.8	7.31-70	11.2-112
AFUE* or CE/TE**	95%*	95%*	95%*	95%*	96%**
Min. Gas Supply Pressure (NG or Propane) – inch w.c.	4	4	4	4	4
Max. Gas Supply Pressure (NG or Propane) – inch w.c.	14	14	14	14	14
Ambient Temperature – Low (°F/°C)	32/0	32/0	32/0	32/0	32/0
Ambient Temperature – High (°F/°C)	122/50	122/50	122/50	122/50	122/50
Max. Relative Humidity (Non-Condensing)	90%	90%	90%	90%	90%
Min. Water Temperature (°F/°C)	34/1	34/1	34/1	34/1	34/1
Max. Water Temperature – (Electronic High Limit) (°F/°C)	190/88	190/88	190/88	190/88	190/88
Max. ΔT – Supply/Return (Electronic Fence) (°F/°C)	40/22	40/22	40/22	40/22	40/22
Max. Water Temperature Lockout Limit (°F/°C)	201/94	201/94	201/94	201/94	201/94
Power (120Vac/60Hz) at Full Fire – watts (w/o pumps)	90	79	90	127	190
Weight (Empty) – lbs/kg	67/30.4	78/35.4	88/39.9	162/74	240/110
Pressure Vessel Water Content – USG/Liters	1.88/7.12	2.8/10.56	3.51/13.29	4.64/17.56	6.66/25.21
Max. Boiler Flow Rate – USgpm	14	19	25	25	45
Min. Boiler Flow Rate – USgpm	2	3	4	6	20
Max. Operating Water Pressure – psig	50	50	50	30	80
Min. Operating Water Pressure – psig	8	8	8	8	8
Relief Valve Pressure – psig	30	30	30	30	30
Approved Installation Altitude – ASL	0-12,000'	0-12,000'	0-12,000'	0-12,000'	0-12,000'
Ultra Low NOx	Meets 14 ng/J NOx requirements – SCAQMD Rule 1146.2 compliant				



Boilers

Dimensions

RHBH-FT110, RHBH-FT150 & RHBH-FT199

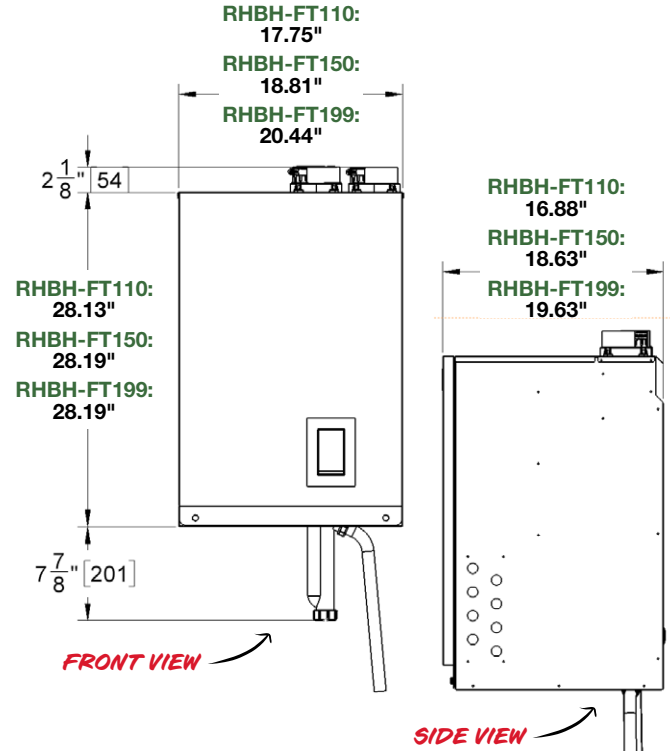
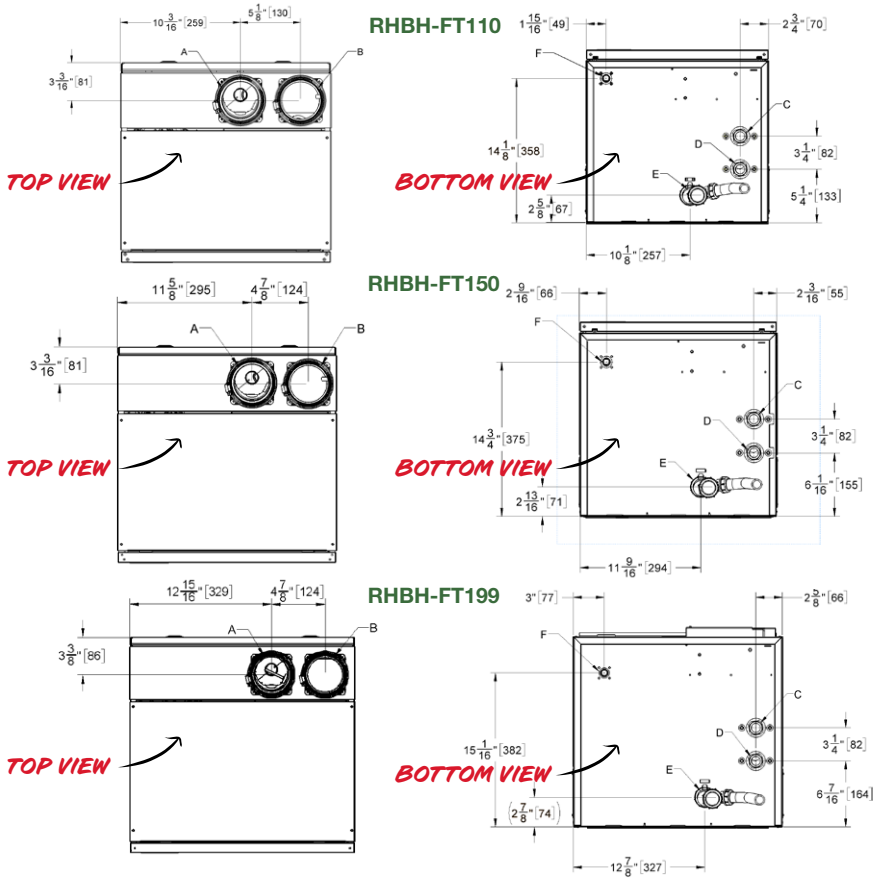

PIPING CONNECTIONS			
MODEL NO.	RHBH-FT110	RHBH-FT150	RHBH-FT199
A Flue Outlet	3" Schedule 40 or 3" PP (80mm)		
B Combustion Air Inlet	3" Schedule 40 or 3" PP (80mm)		
C Return Water Inlet (Tepid)	1" NPT-M		
D Supply Water Outlet (Hot)	1" NPT-M		
E Condensate Outlet	3/4" Hose		
F Gas Inlet	1/2" NPT-F		

VENTING	MAXIMUM EQUIVALENT LENGTHS		
	RHBH-FT110	RHBH-FT150	RHBH-FT199
PVC, CPVC, RIGID PP			
2"	100'	50'	Not Permitted
3"	240'	170'	100'
90° Vent Elbow	Equivalent to 8'		
90° Long Sweep Elbow	Equivalent to 5'		
45° Elbow	Equivalent to 3'		
PP 87-90° Elbows	Equivalent to 8'		
2" Stainless Steel Sidewall Terminal - Exhaust Vent (P-256)	Exhaust: Equivalent to 20' Intake: Equivalent to 0'	Not Permitted	
3" Stainless Steel Sidewall Terminal - Exhaust Vent (P-257)	Exhaust: Equivalent to 20' Intake: Equivalent to 0'		
Flexible PP 3" Flexible	45' (max.) Lineal x 1.2 = Equiv.	45' (max.) Lineal x 2 = Equiv.	30' (max.) Lineal x 3.33 = Equiv.

CLEARANCE FROM BOILER CABINET		
SURFACE	MIN. DISTANCE*	RECOMMENDED DISTANCE**
Front	2"	24"
Rear Flue Connection	0"	0"
Left Side	0"	4" (allow acces to water connections)
Right Side	1"	4" (allow acces to water connections)
Top	2"	6" (for vent connection)
Bottom	0" (clearance for pipes)	12" (for condensate trap and piping)

* From Combustible Surfaces ** For Installation & Service



Boilers

Dimensions RHBH-FT260 & RHBH-FT399

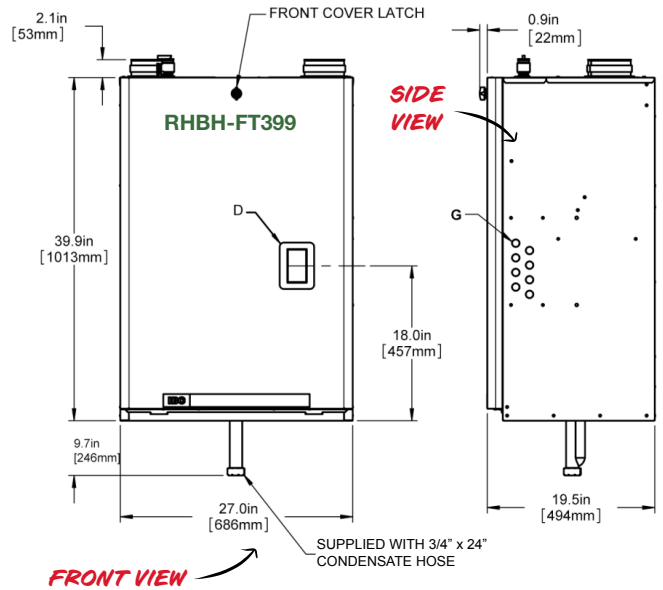
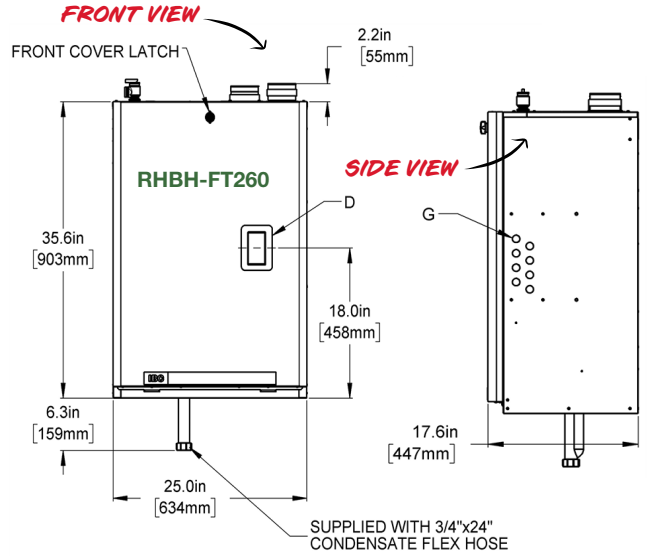
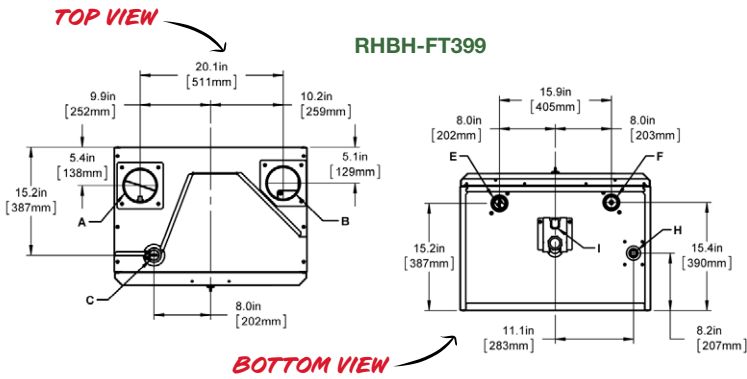
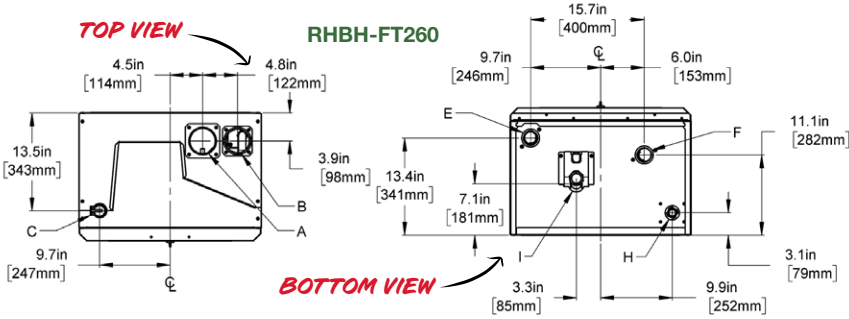

PIPING CONNECTIONS			
MODEL NO.		RHBH-FT260	RHBH-FT399
A	Flue Outlet	3" Schedule 40	4" Schedule 40
B	Combustion Air Inlet	3" Schedule 40	4" Schedule 40
C	Relief Valve & Air Vent	3/4" NPT-F	
D	Touchscreen Display	2-1/4" x 4	
E	Supply Water Outlet (Hot)	1-1/2" NPT - M	
F	Return Water Inlet (Tepid)	1-1/2" NPT - M	
G	Knock-Outs (8)	1-1/2"	
H	Gas Inlet	3/4" NPT-F	
I	Condensate Outlet	3/4" Hose	

VENTING		
PVC, CPVC, RIGID PP	RHBH-FT260	RHBH-FT399
3"	200'	—
4"	—	200'
90° Vent Elbow	Equivalent to 8'	
90° Long Sweep Elbow	Equivalent to 5'	
45° Elbow	Equivalent to 3'	
PP 87-90° Elbows	Equivalent to 8'	
3" Stainless Steel Sidewall Terminal - Exhaust Vent (P-257)	Exhaust: Equivalent to 65' Intake: Equivalent to 0'	
3" CPVC (P-257 adaptor)	—	Allow 3.2' equivalent for each 1'
Flexible PP 3" Flexible	60' (max.) lineal x 3.33 = equiv.	—
Flexible PP 4" Flexible	—	160' max. using 1.2 x for equiv. length

CLEARANCE FROM BOILER CABINET				
SURFACE	RHBH-FT260		RHBH-FT399	
	MIN. DISTANCE*	RECOMMENDED DISTANCE**	MIN. DISTANCE*	RECOMMENDED DISTANCE**
Front	2"	24"	2"	24"
Rear Flue Connection	0"	0"	0"	0"
Left Side	1"	4" (allow access to water connections)	1"	0" (to non-combustibles)
Right Side	1"	4" (allow access to water connections)	1"	4" (for electric and gas if required)
Top	2"	6" (for vent connection)	12"	12" (for vent connection)
Bottom	—	12" (for condensate trap and piping)	—	12" (for condensate trap and piping)

* From Combustible Surfaces ** For Installation & Service



Boilers

Accessories

RHBH-FT110, RHBH-FT150 & RHBH-FT199



Accessories

RHBH-FT260 & RHBH-FT399

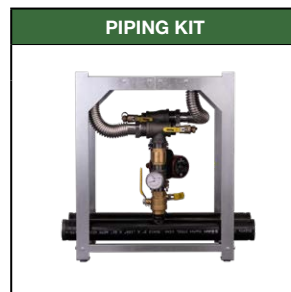

In keeping with its policy of continuous progress and product improvement, Rheem reserves the right to make changes without notice.

Contact Us

Customer Service, Warranty & Parts
800.621.5622

Technical Service
833.212.9276

Plumber Support Group
866.339.2388